

Single high speed Compact size CAN isolation transceiver module

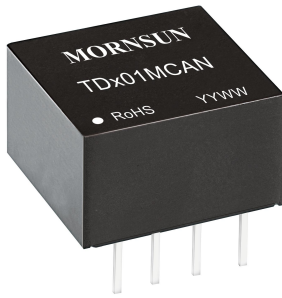

FEATURES

- Meet ISO 11898-2 standard
- Two- port isolation : 2.5kVDC
- High baud rate up to 1Mbps
- Operating temperature range: -40°C to +105°C
- Bus timeout protection
- The bus can support at least 110 nodes
- Compact size, standard DIP8 package
- EN60950 approval

Single-channel high-speed small-size CAN isolation transceiver module TD301MCAN / TD501MCAN series' main function is to convert TTL / CMOS level to CAN bus differential level, and achieve signal isolation, which is integrated with power isolation, signal isolation, CAN transceiver and Bus protection inside. The product comes with isolated power supply, can achieve 2500VDC electrical isolation. The products is in ultra-small size package, only 40% size of general products, which make it more easily embedded in user device, the device can easily achieve CAN bus network connectivity.

Selection Guide

Certification	Part No.	Power Supply Input (VDC)	Baud Rate (bps)	Static Current (mA)	Maximum Operating Current (mA)	Bus Maximum Voltage (V)	Number of Nodes
CE	TD301MCAN	3.3	40k-1M	30	60	±58	110
	TD501MCAN	5	40k-1M	24	50	±58	110

Limit Specifications

Item	Operating Conditions	Min.	Typ.	Max.	Unit
Input Surge Voltage (1sec.max.)	3.3V series	-0.7	--	5	VDC
	5.0V series	-0.7	--	7	
Pin Welding Resistance Temperature	Welding spot is 1.5mm away from the casing, 10 seconds	--	--	300	°C

Input Specifications (3.3V series)

Item	Symbol	Min.	Typ.	Max.	Unit	
Power Supply Input Voltage	VCC	3.15	3.3	3.45	VDC	
TXD Logic Level	High-level	V _{IH}	0.7VCC	--		VCC
	Low-level	V _{IL}	0	--		0.8
RXD Logic Level	High-level	V _{OH}	VCC-0.4	3.1		--
	Low-level	V _{OL}	--	0.2		0.4
TXD Drive Current	I _r	2	--	--		mA
RXD Output Current	I _r	--	--	10		
Serial Interface	Standard CAN controller interface for +3.3V.					

Input Specifications (5.0Vseries)

Item	Symbol	Min.	Typ.	Max.	Unit	
Power Supply Input Voltage	VCC	4.75	5	5.25	VDC	
TXD Logic Level	High-level	V _{IH}	0.7VCC	--		VCC
	Low-level	V _{IL}	0	--		0.8
RXD Logic Level	High-level	V _{OH}	VCC-0.4	4.8		--
	Low-level	V _{OL}	--	0.2		0.4
TXD Drive Current	I _r	2	--	--		mA
RXD Output Current	I _r	--	--	10		
Serial Interface	Standard CAN controller interface for both +3.3V and +5.0V.					

Transmission Specifications

Item	Symbol	Min.	Typ.	Max.	Unit	
Data Delay	TXD Transmit Delay	t_r	--	55	115	ns
	RXD Receive Delay	t_R	--	65	135	
	Cycle Delay	$t_{PRO(TXD-RXD)}$	--	120	250	
Dominant Timeout	$t_{to(dom)TXD}$	0.3	1	12	ms	

Output Specifications

Item	Symbol	Min.	Typ.	Max.	Unit	
Dominant Level (Logic 0)	CANH	$V_{(OD)CANH}$	2.75	3.5	4.5	VDC
	CANL	$V_{(OD)CANL}$	0.5	1.5	2.25	
Recessive Level (Logic 1)	CANH	$V_{(OR)CANH}$	2	2.5	3	
	CANL	$V_{(OR)CANL}$	2	2.5	3	
Difference Level	Dominant Level (Logic 0)	$V_{diff(d)}$	1.5	2	3	
	Recessive Level (Logic 1)	$V_{diff(r)}$	-0.05	0	0.05	
Bus Pin Maximum Withstand Voltage	V_x	-58	--	+58		
Bus Transient Voltage	V_{trt} , Meet ISO7637-3 standard	-150	--	+100		
Bus Pin Leakage Current	($V_{CC}=0V, V_{CANH/L}=5V$)	-5	--	5	uA	
Difference Load Resistance	R_L	45	60	65	Ω	
Differencel Input Impedance	R_{diff}	19	30	52	k Ω	
CAN Bus Interface	Meet ISO/DIS 11898 standard Twisted-pair output					

General Specifications

Item	Operating Conditions	Value
Isolation Voltage	Testing for 1 minute, leakage current <1mA,	2.5kVDC
Insulation Resistance	Isolation voltage 500VDC	100M Ω
Operating Temperature		-40 $^{\circ}$ C to +105 $^{\circ}$ C
Transportation and Storage Temperature		-50 $^{\circ}$ C to +125 $^{\circ}$ C
Operating Humidity	Non-condensing	10%-90%
Casing Temperature Rise	$T_a=25^{\circ}$ C, Free air convection	25 $^{\circ}$ C
Safety Standard		EN60950
Safety Certification		
Safety Class		CLASS III
Application Environment		The presence of dust, fierce vibration, impulsion and corrosive gas may cause damage to the product

Physical Specifications

Casing Material	Black flame-retardant and heat-resistant plastic (UL94 V-0)
Dimensions	12.70*10.16*7.70 mm
Weight	2g(Typ.)
Cooling Method	Free air convection

EMC Specifications

EMS	ESD	IEC/EN 61000-4-2	Contact $\pm 4kV$ /Air $\pm 8kV$ (Bare component, Signal port)	Perf. Criteria A
	RS	IEC/EN 61000-4-3	10V/m (Bare component)	Perf. Criteria A
	EFT	IEC/EN 61000-4-4	$\pm 2kV$ (Bare component, Signal port)	Perf. Criteria B
	Surge	IEC/EN 61000-4-5	$\pm 2kV$ (Line to ground) (Bare component, Signal port)	Perf. Criteria A
	CS	IEC/EN 61000-4-6	3Vr.m.s (Bare component)	Perf. Criteria A

Application Precautions

1. Please read the instructions carefully before use; call for our technical support if you have any questions;
2. Do not use the product in hazardous areas;
3. This product is powered by DC power supply , AC power supply is prohibited;
4. Do not dismount and assemble the product without permission to avoid failure or malfunction of equipment;

After-sales service

1. Ex-factory inspection and quality control have been strictly conducted for the product; if there occurs abnormal operation or possibility of failure of internal module, please contact the local representative or our technical support;
2. The warranty period for the product is 3 years as calculated from the date of delivery. If any quality problem occurs under normal use within the warranty period, the product can be repaired or changed for free.

Applied circuit

Refer to the CAN Industrial Bus Interface Isolating Module Application Manual.

Design Reference

1. Typical application circuit

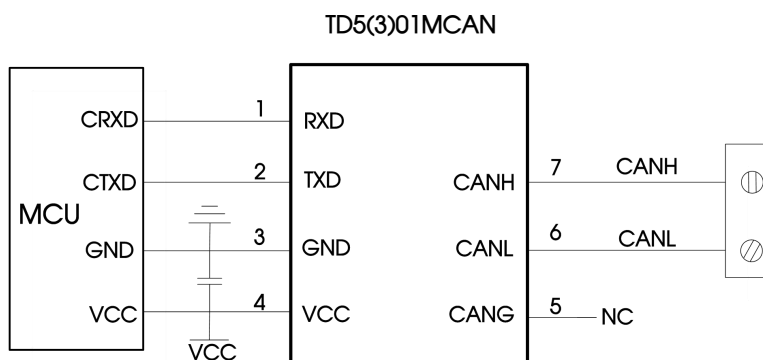

Fig.1

In general, the module, which is properly connected to the power supply, CAN controller and CAN bus network interface, can be used directly by customers without adding peripheral circuits. Figure 1 shows a typical application circuit connection for a module.

Notes: The CAN controller logic level should be compatible with TD5(3)01MCAN isolated CAN transceiver module.

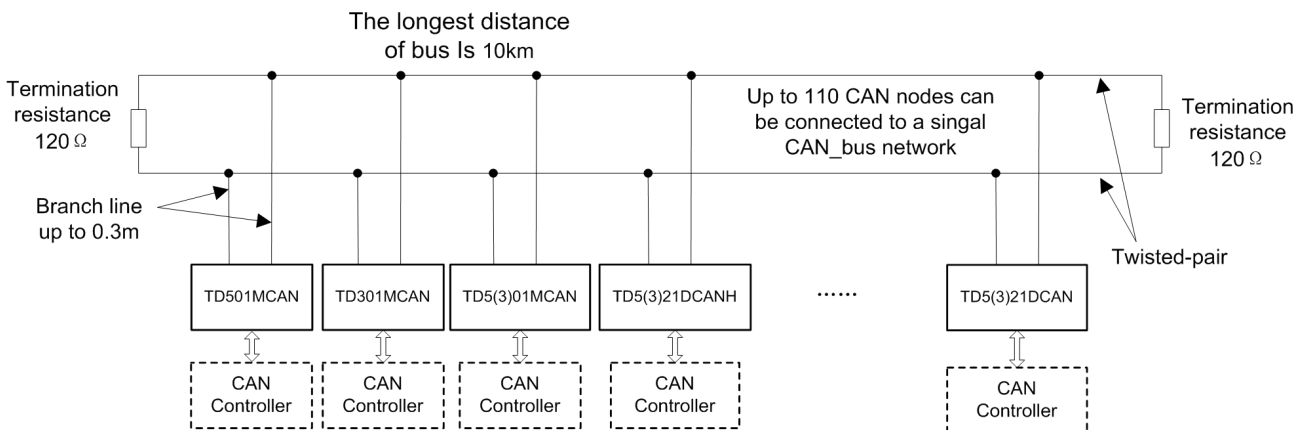

Fig.2

As shown in Figure 2, a single CAN-bus network can connect up to 110 single-channel TD_CAN isolated CAN transceiver modules. The universal type module can support a max. communication distance of 10km while the high-speed type module can support a max communication distance of 1km with baud rate beyond 40kbps. If looking to access more nodes or longer communication distance, it can be achieved by using CAN repeaters or other expansion equipment.

Notes: The communication distance of the bus is related to the communication speed and field application. It can be designed according to the actual application and reference standard. The communication cable is recommended to twisted pair or shielded twisted pair and should stay away from the interference source. For long-distance communication, the terminal resistance value needs to be selected according to the communication distance and the cable impedance and the number of nodes.

2. Recommended port protection circuit

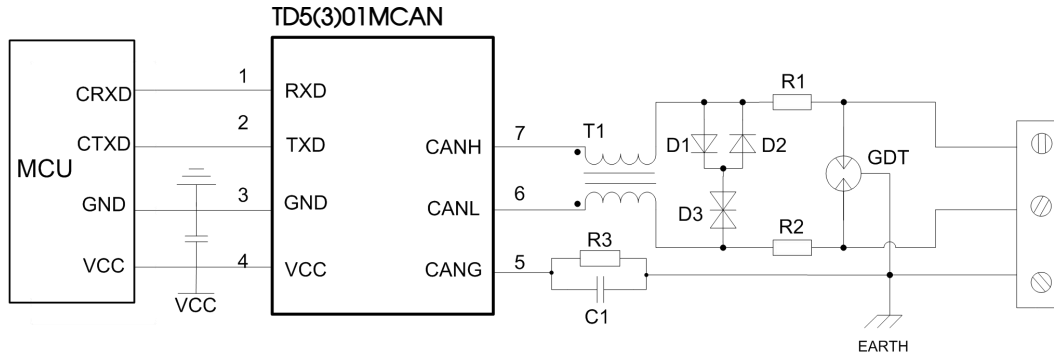

Fig.3

Notes: Twisted pair shield grounded reliably.

Parameter declaration:

Components	Recommended parameters	Components	Recommended parameters
R3	1MΩ, 1206	R1、R2	2.7Ω /2W
C1	102, 2kV	D1、D2	1N4007
T1	ACM2520-301-2P	D3	SMBJ15CA
GDT	B3D090L		

When the module is used in harsh field environment, it is susceptible to large energy of lightning strike. In this case, it is necessary to add protection circuit to the CAN signal port to protect the module from damage and ensure the reliability of bus communication. Figure 3 provides a recommended protection circuit design for high-energy lightning surges, with a degree of protection related to the selected protection device. Parameter description lists a set of recommended circuit parameters, which can be adjusted according to the actual application situation. Also, when using the shielded cable, the reliable single-point grounding of the shield must be achieved.

Notes: This recommended parameter is only the recommended value, which is subject to the actual application.
Recommended R1, R2 use PTC, D1, D2 use fast recovery diodes.

3. For more information, please find the application note on www.mornsun-power.com

Dimensions and Recommended Layout

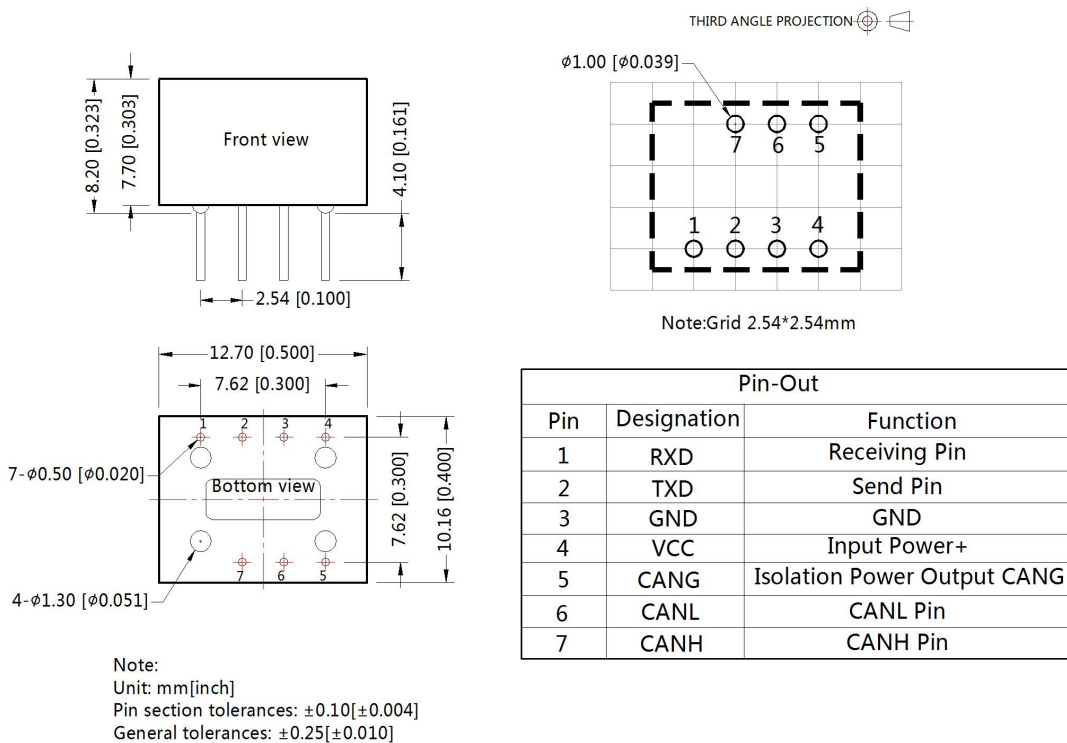

Notes:

1. Packing Information please refer to 'Product Packing Information'. Packing bag number: 58200011;
2. Unless otherwise specified, data in this datasheet should be tested under the conditions of $T_a=25^{\circ}\text{C}$, humidity<75% when inputting nominal voltage and outputting rated load;
3. All index testing methods in this datasheet are based on our Company's corporate standards;
4. The performance indexes of the product models listed in this datasheet are as above, but some indexes of non-standard model products will exceed the above-mentioned requirements, and please directly contact our technician for specific information;
5. We can provide product customization service;
6. Products are related to laws and regulations: see "Features" and "EMC".
7. Our products shall be classified according to ISO14001 and related environmental laws and regulations, and shall be handled by qualified units

Mornsun Guangzhou Science & Technology Co., Ltd.

Address: No. 5, Kehui St. 1, Kehui Development Center, Science Ave., Guangzhou Science City, Luogang District, Guangzhou, P. R. China
Tel: 86-20-38601850-8801 Fax: 86-20-38601272 E-mail: info@mornsun.cn