

SCM1501B Contactor Power Saving Controller

Features

- The input voltage is detected in real time, and the contactor operating voltage can be accurately set
- It can work in a wide input voltage range of 2.5:1
- The pick-up current and the holding current can be set separately, and the contactor coil design is simpler
- With built-in analog frequency jitter, it is easy to solve EMI problems
- The chip's power supply range is 16.5V~500V, which meets most of the contactor input voltage requirements
- With fast shutdown function, it reduces the contactor shutdown delay
- AC input busbar does not require large capacitance

Package

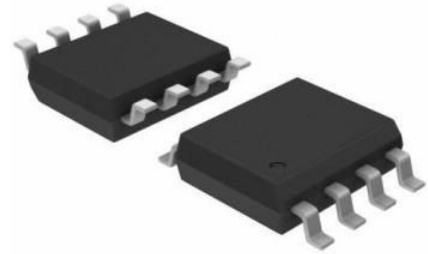

Product package: SOP-8.

Please see "Ordering Information" for details

Applications

- Various contactor power saving transformation
- Wide voltage AC/DC universal contactor control

Functional Description

The SCM1501B is a contactor power-saving controller that reduces the pick-up and holding power consumption of the contactor. The SCM1501B has a built-in high-voltage startup circuit that can quickly start the controller with a charging current of 4mA (typ.) within the input voltage range of 16.5V~500V, so as to respond quickly when the contactor is operated. If the auxiliary power supply is not used, SCM1501B will take power directly from the input to realize self-power supply. In addition, the SCM1501B can also control the contactor coil to achieve high current pick-up and low current holding. During the low current holding stage, when the input undervoltage occurs or the controller is disabled, the controller activates the fast shutdown function to quickly disconnect the contactor to reduce the influence of the SCM1501B on the disconnecting performance of the contactor.

Typical Application Circuit

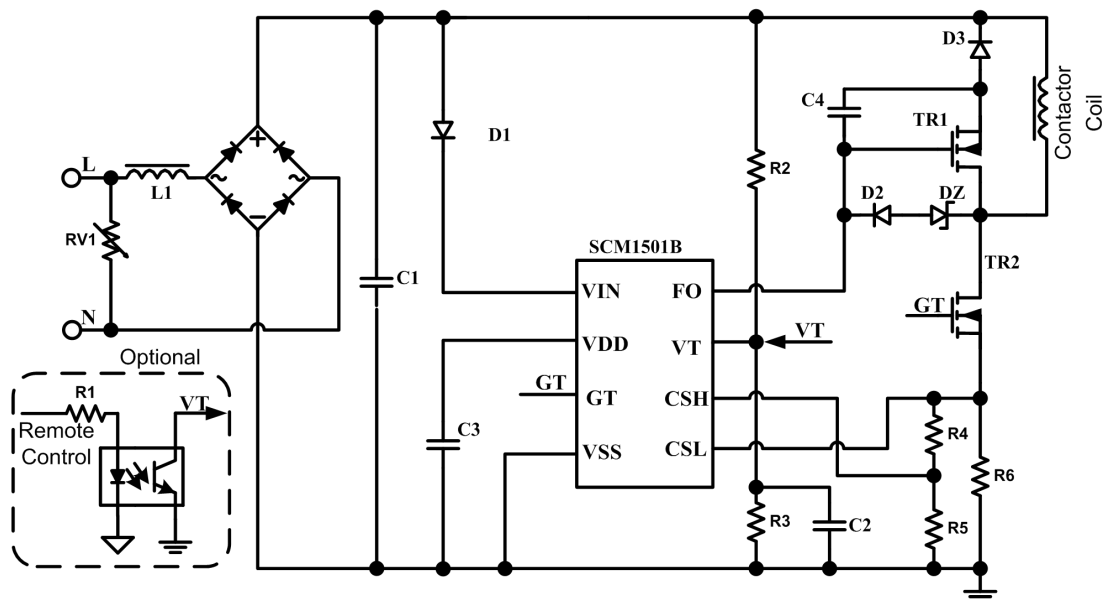

Absolute Maximum Ratings

Test conditions: Free-air, normal operating temperature range (unless otherwise specified), voltage reference is ground.

PARAMETER	SYMBOL	MIN	MAX	UNIT
V _{VIN}	HV starting voltage	16.5	500	V
V _{VDD}	Bias supply voltage		20	
V _{GT}	GT pin voltage	-0.6	20	
V _{VT} , V _{CSL} , V _{CSH}	Voltage range	-0.6	6	
T _J	Working junction temperature range	-40	150	°C
T _{STG}	Storage temperature	-40	150	
	Lead temperature of 0.6mm from the outer casing within 10 seconds		260	
	Electrostatic discharge (ESD) rating	Human body model (HBM, except I/O to I/O)		V
			2000	

Note: Permanent damage to the device may occur if the stress values listed in the "Maximum Ratings" table are exceeded. The reliability of the device may be affected by long-term operation under extreme rating conditions. All voltage values are based on the Earth (GND) reference. Current is the positive input and negative output of the specified terminal.

Electrical Characteristics

Unless otherwise stated, the following parameters were tested under normal temperature and pressure and in an unsealed environment.

SYMBOL	PARAMETER	TEST CONDITIONS	MIN	TYP	MAX	UNIT
I _{START}	Starting current	V _{VIN} =60V current flowing from the VDD pin		4		mA
V _{VIN_BV}	VIN pin breakdown voltage	I _{VIN} =10uA	560			V
V _{VDD_ON}	Drive signal output point VDD pin voltage	V _{VT} =3V	9.95	11.05	12.16	V
V _{VDD_OFF}	Drive signal turn-off point VDD pin voltage	V _{VT} =3V	9.45	10.5	11.55	V
V _{VDD_HD}	VDD self-power supply sustaining voltage	V _{VIN} =60V	15.2	17	19.2	V
I _{START_OFF}	Self-powered off, VIN bias current	V _{VIN} =400V			10	uA
I _{VDD_STATE}	VDD pin chip static operating current	V _{VDD} =18V, V _{VT} =0V	125	250	375	uA
V _{ACT_AC}	VT pin contactor operating voltage	V _{VDD} =18V	2.26	2.4	2.54	V
V _{OFF_AC}	VT pin contactor turn-off voltage	V _{VDD} =18V	1.5	1.6	1.7	V
T _{D_CHANGE}	Mode switching delay for pick-up and holding	V _{VDD} =18V	80.36	98	115.64	ms
F _{BUCK}	Post-stage average switching frequency	V _{VDD} =18V, normal operation	21.15	23.5	25.85	kHz
F _{SK}	Frequency jitter	Peak-to-peak jitter compared to the average frequency, T = 27 ° C		±6.5		%
V _{CSHT}	CSH pin pick-up current comparison threshold	V _{VDD} =18V, pick-up stage	1.13	1.2	1.27	V
V _{CSLT}	CSL pin holding current comparison threshold	V _{VDD} =18V, holding stage	0.28	0.3	0.32	V
T _{ON_MIN}	Minimum on time	V _{VDD} =18V, V _{CSL} =1.0V	260	520	780	ns
T _{D_STOP}	Shutdown detection delay	V _{VDD} =18V, V _{CSL} =1.0V	0.32		1.50	ms

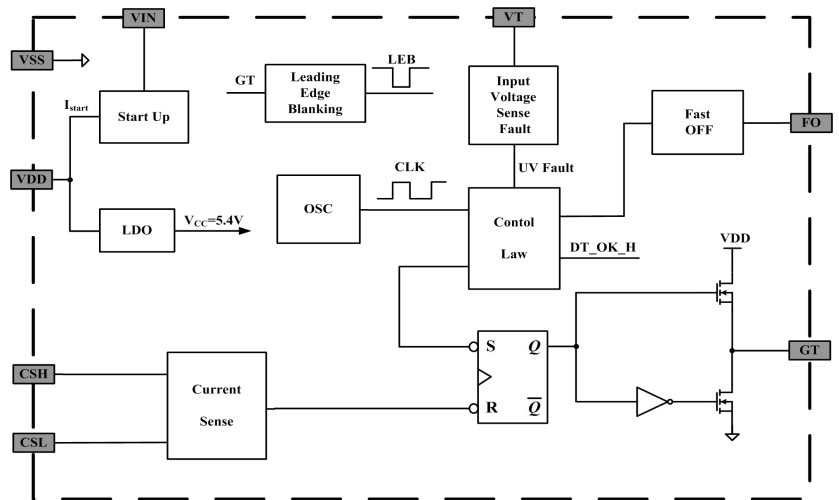
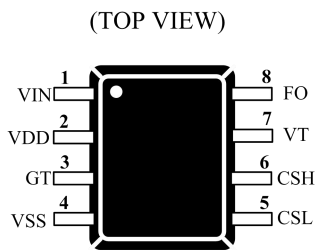

Pin Description

NUMBER	NAME	I/O	DESCRIPTION
1	VIN	P	High voltage starting circuit input
2	VDD	P	Chip supply pin
3	GT	O	Power MOSFET drive
4	VSS	P	Chip ground
5	CSL	I	Holding state current sampling pin
6	CSH	I	Pickup state current sampling pin
7	VT	I	Input voltage detection
8	FO	O	Bootstrap drive for fast turn-off transistor

Pin Function Descriptions

VIN (high voltage input): The high voltage power input port of the controller can be connected to the DC input voltage below 500V. The DC input voltage is stepped down to the VDD pin via the LDO circuit inside the VIN pin. If there is no auxiliary power supply, the VDD pin voltage will eventually stabilize at 17V.

VDD (power supply terminal): power supply port of the controller, external bypass capacitor C_{VDD} . After power-on, the built-in LDO circuit charges the capacitor C_{VDD} and the VDD voltage rises. When the VDD voltage is charged to the startup threshold V_{VDD_ON} the controller begins to output the drive signal, while the startup circuit still charges the capacitor until $V_{VDD}=V_{VDD_HD}$; If there is no auxiliary power supply, the LDO circuit will continue to operate to maintain $V_{VDD}=V_{VDD_HD}$.

GT (drive output): Outputs a square wave signal with an average frequency of 23.5 kHz. During the pickup stage, the contactor inductance is small, so there is a case where the duty ratio is as long as 100%. In this stage, the duty ratio is without any regularity; After entering the holding stage, the inductance of the contactor becomes larger and the duty ratio becomes regular. At this time, the square wave frequency can be seen to have periodic jitter, the frequency is jittered within the range of $\pm 6.5\%$.

VSS (ground): Signal reference ground.

CSH (pick-up current detection): The high current detection pin only controls the duty cycle of the square wave signal output by the GT pin during the pickup stage. That is, when the CSH pin voltage is greater than 1.2V, the GT pin outputs low power level.

CSL (holding current detection): A small current detection pin that controls the duty cycle of the square wave signal output from the GT pin only during the holding stage. That is, when the CSL pin voltage is greater than 0.3V, the GT pin outputs low power level.

VT (input voltage detection): The external voltage divider sampling input voltage. In AC applications, the contactor operates at 2.4V and the shutdown voltage is 1.6V. The shutdown delay set by the controller is 0.66ms, which means that the input undervoltage protection will be entered when the VT pin voltage is less than 1.6V and lasts for 0.66ms.

FO (quick turn-off tube drive output): In normal operation mode, as long as the GT pin outputs a high level, $V_{FO}=V_{VDD}-0.6-V_{CSL}$. In order to charge the FO pin to the maximum value, it is necessary to charge the $V_{VDD}=V_{VDD_HD}$ to $V_{VDD}-0.6$ when the V_{CSL} is not very large after the first rising edge of the GT pin signal appears, so as to minimize the on-resistance of the fast switch-off transistor. During the holding stage, if the controller enters the input undervoltage protection, the FO will draw 1.2mA, so that the fast turn-off transistor TR1 operates in the sub-threshold region, and the demagnetization current slope of the inductor becomes larger, thereby reducing the delay of contactor contact pop-up. See "Fast shut-off" section for details.

High Voltage Startup Operation

The SCM1501B is capable of taking power from the input voltage, charging the VDD bypass capacitor to V_{VDD_ON} with a current of 4mA (typ.) to output the GT drive signal, and then the LDO continues to supply the VDD bypass capacitor until $V_{VDD}=V_{VDD_HD}$. If there is no 18V~20V auxiliary power supply to the controller, the SCM1501B will continue to draw power from the input to maintain $V_{VDD}=V_{VDD_HD}$.

In AC applications, when the system is operating in the pick-up stage, the input voltage waveform is a head wave. A diode needs to be connected in series with the VIN pin. If necessary, a voltage divider resistor is connected in series to reduce the startup power consumption of the SCM1501B.

Current Design

The SCM1501B uses the CSL and CSH pins to set the peak current in the holding stage and the pick-up stage for programmable design, and the peak current ratio of the two stages ranges from 4 to 20 times wide. As shown in the typical application circuit, the peak currents of these two stages satisfy the following equation:

Peak current I_H during the pick-up stage:

$$I_H = \frac{V_{CSTH} \cdot (R4 + R5)}{R5 \cdot R6}$$

Peak current I_L during the holding stage:

$$I_L = \frac{V_{CSTL}}{R6}$$

It can be seen that by designing the ratio of R4 and R5, the programmable design of the ratio I_H/I_L of the peak current can be realized.

Input Undervoltage Protection

In the AC application, when the SCM1501B is started, if $V_{VT} < 1.6V$, the GT does not output the drive signal. When $V_{VT} > 2.4V$ and $V_{VDD_ON} \geq V_{VDD_ON}$, the GT starts to output the drive signal and enters the pick-up stage. Here 2.4V is the action voltage V_{ACT_AC} of contactor. In AC application, the return difference of V_{ACT_AC} is 0.8V, that is, the AC turn-off voltage $V_{OFF_AC} = 1.6V$ of contactor. When V_{VT} is less than 1.6V and lasts for 2ms, it enters the input undervoltage protection and turns off the driving signal output of GT. And depending on the state of the system, choose whether to let the fast shut-off transistor work in the sub-threshold area, as described in the section "Quick Shut down".

Pick-up/holding switchover

Taking AC applications as an example, when $V_{VT} > 2.4V$, start timing for 98 ms (if input under-voltage protection is entered during this period, the timing is cleared). SCM1501B transits from the pick-up stage to the holding stage, and from the CSH pin to the CSL pin effectively.

Switching Frequency

To avoid audible noise, the SCM1501B has an average switching frequency of 23.5 kHz. To optimize EMI characteristics, the instantaneous value of the controller's switching frequency is $\pm 6.5\%$ peak-to-peak jitter compared to the average.

Quick Shutdown

As shown in the typical application circuit, when the TR2 is turned on, the FO pin outputs 5 mA of current to charge the FO bootstrap capacitor C4, so that the fast turn-off transistor TR1 operates in a on state, so that to achieve small current slope demagnetization under normal operating conditions.

When the voltage of VT pin is detected to be less than 1.6V up to 0.66ms, and SCM1501B works in the holding stage. The peak slope voltage of CSL is 0.3V, the enable signal switches off the circuit quickly. The FO pin "extracts" 1.2mA current. At this time, the FO bootstrap capacitor C4 discharges until the fast switch-off TR1 works in the sub-threshold region, thus maintaining the slope of the inductance demagnetization current at $(V_Z + 2V_F + V_{TH})/L_M$ to reduce the delay of the contactor opening. V_Z is the clamp voltage of the regulator, V_F is the forward voltage of the diodes D1 and D2. It is considered that the forward voltage of D1 and D2 is the same, V_F is the threshold voltage of TR1 and L_M is the inductance of the inductive element L2.

After 98ms of the start of the enable signal generation, the fast shutdown circuit stops operating, thereby saving 1.2 mA of current. The 1.2 mA current has a parameter range of 0.989 mA to 1.6 mA due to process variations.

Ordering Information

Part Number	Package Type	No. of Pins	Silk Screen Marking	Reel information
SCM1501BSA	SOP8	8	SCM 1501BSA YM	3K/REEL

Product marking

SCM1501XYZ :

- (1) SCM1501 = Product designation.
- (2) X= Version information (Letter from A-Z).
- (3) Y = Package definition; (S = SOP package).
- (4) Z = Operating temperature range (C = 0°C to +70°C, I = -40°C to +85°C, A = -40°C to +125°C, M = -55°C to +125°C).
- (5) YM = Date code for product traceability; Y = code for production year; M = code for production month.

Mechanical Package Information

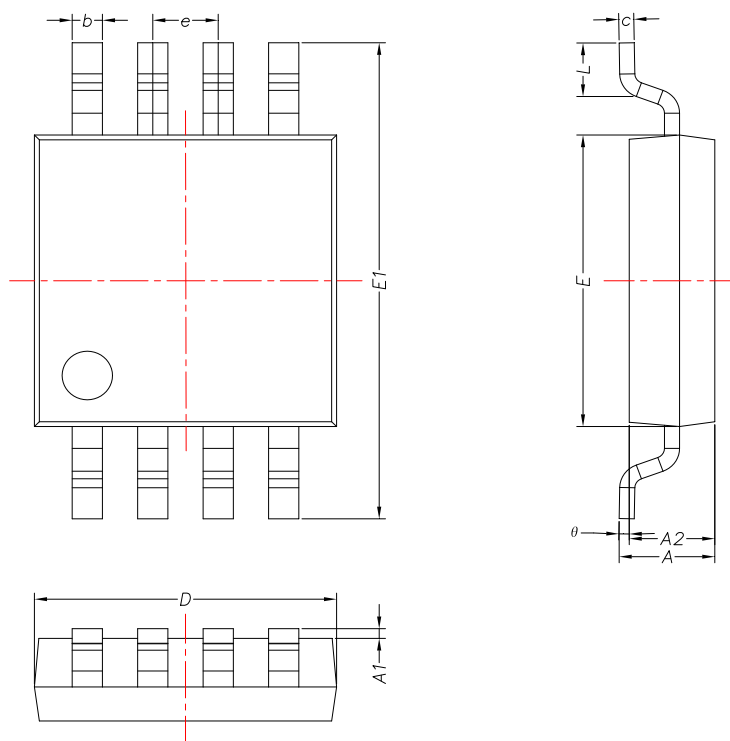

No.	SOP8			
	Dimensions in millimeters		Dimensions in inches	
	Min	Max	Min	Max
A	1.350	1.750	0.053	0.069
A1	0.100	0.250	0.004	0.010
A2	1.350	1.550	0.053	0.061
b	0.330	0.510	0.013	0.020
c	0.170	0.250	0.007	0.010
D	4.700	5.100	0.185	0.201
e	1.270 (BSC)		0.050 (BSC)	
E	5.800	6.200	0.228	0.244
E1	3.800	4.000	0.150	0.157
L	0.400	1.270	0.016	0.050
θ	0°	8°	0°	8°

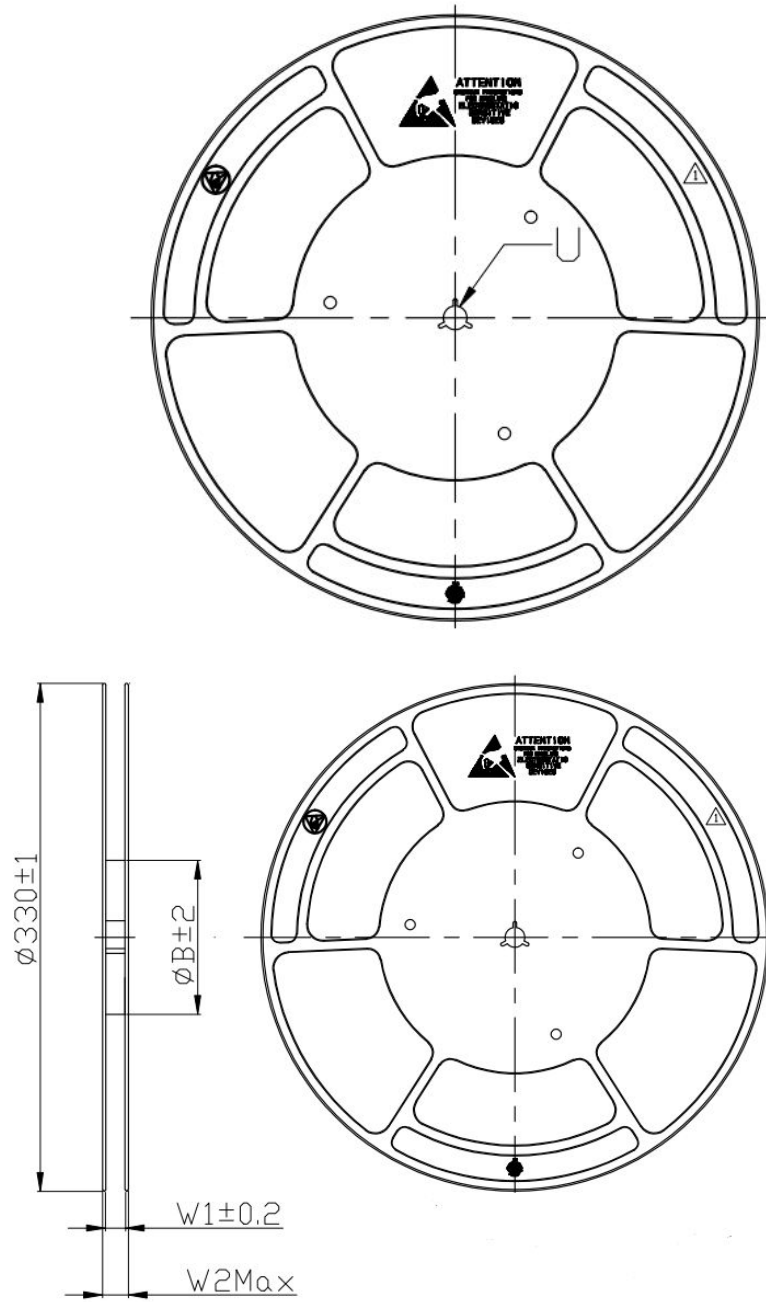

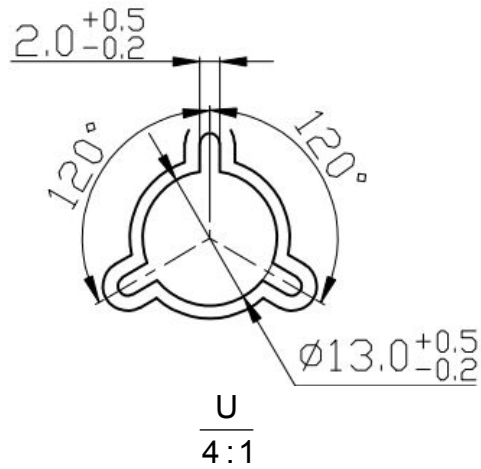

Basic Disk Dimensions (mm)				
Package Type	Load Band Width	B	W1	W2Max
SOP8	12	180	12.4	18.4

Technical requirement :

- Color : Blue (Reference color number :
 PANTONE DS 196-1 C ; C100 M70 Y0 K0
 PANTONE DS 197-1 C ; C100 M70 Y0 K10
 PANTONE DS 205-1 C ; C100 M60 Y0 K20
 PANTONE DS 205-2 C ; C85 M50 Y0 K20
 PANTONE DS 206-2 C ; C85 M50 Y0 K35
 PANTONE DS 219-1 C ; C90 M50 Y5 K15)
- Dimensions and tolerances according to ANSI/EIA-481-C-2003;
- Disk surface good finish, no warping deformation ;
- External packing in good condition, no damage or pollution;

Mornsun Guangzhou Science & Technology Co., Ltd.

Address: No. 5, Kehui St. 1, Kehui Development Center, Science Ave., Guangzhou Science City, Huangpu District, Guangzhou, P. R. China

Tel: 400-1080-300

Fax: 86-20-38601272

E-mail: sales@mornsun.cn

MORNSUN[®]

广州金升阳科技有限公司
MORNSUN GUANGZHOU SCIENCE & TECHNOLOGY CO., LTD.

2019.04-A/1 Page 7 of 7