

1200W, wide voltage input, isolated voltage regulator single output, DC/DC module power supply



Patent Protection RoHS

FEATURES

- Wide input voltage range: 360-400 VDC
- High efficiency up to 95%
- Enhanced insulation, isolation voltage 3000VAC
- Base plate operating temperature: -40°C to +100°C
- Input under voltage and over voltage protection, output over voltage, over current, short circuit protection, over temperature protection
- Supports the PMBus function
- Meet the EN62368 certification standard

VRF4D12HBO-1200WR3P output power is 1200W, 360-400VDC wide voltage input range, efficiency up to 95%, isolation voltage 3000VAC, housing allowed operating temperature -40°C to +85°C, with input under-voltage/over-voltage protection, output over-voltage/over-current/short circuit protection, over-temperature protection, remote control, output voltage regulation, current sharing, through the peripheral to meet the CISPR32/EN55032 CLASS A, widely used in industrial control, communication and other fields.

Selection Guide

Certification	Part No.	Input Voltage (VDC)		Output		Full Load Efficiency ^② (%) Min./Typ.	Max. Capacitive Load(μF)
		Nominal (Range)	Max.	Voltage ^① (VDC)	Current (A) Max./Min.		
--	VRF4D12HBO-1200WR3 P	380 (360-400)	400	12	100/0	93/95	20000

Note:

- ① Input voltage can not exceed this value, otherwise it may cause permanent irreparable damage;
② The maximum capacitive load test results are subject to the electronic load CR mode test.

Input Specifications

Item	Operating Conditions	Min.	Typ.	Max.	Unit
Input Current	Nominal 380VDC input	--	3325/30	3396/60	mA
Reflected Ripple Current	Nominal 380VDC input	--	500	800	
Input Impulse Voltage (1sec.max.)		-0.7	--	430	VDC
Start-up Voltage		--	--	360	
Input Under-voltage Protection		300	--	360	
Input Filter		Pi filter			
Hot Plug		Not available			

Output Specifications

Item	Operating Conditions	Min.	Typ.	Max.	Unit
Output Voltage Accuracy	Nominal input voltage, 0% -100% load	--	--	±2	%
Linear Regulation	100% load, Input voltage from low voltage to high voltage	--	--	±1	
Load Regulation	Nominal input voltage, 5% -100% load	--	--	±1	
Ripple & Noise ^①	Nominal input voltage, 0% -5% load	--	--	600	mVp-p
	Nominal input voltage, 5% -100% load	--	100	300	
Over-temperature Protection	Product surface max. temperature	--	110	--	°C
Over-voltage Protection		110	--	130	%Vo
Over-current Protection	Input voltage range	110	120	130	%Io
Short circuit Protection		Hiccup, continuous, self-recover			

Note:

- ① The test method of ripple and noise adopts the measurement method, and the peripheral circuit is recommended to refer to Figure 3.

General Specifications

Item	Operating Conditions	Min.	Typ.	Max.	Unit	
Isolation Voltage	the test time is 1 minute and the leakage current is less than 5mA	Input-output	3000	--	--	VAC
		Input-housing	2500	--	--	
		Output-housing	500	--	--	
Insulation Resistance	Input-output resistance at 500VDC	100	--	--	MΩ	
Isolation Capacitance	Input-output capacitance at 100KHz/0.1V	--	--	3000	pF	
Operating Temperature	See fig. 2 (Need additional heat dissipation, forced air cooling, water cooling or substrate cooling)	-40	--	+85	℃	
Storage Temperature		-55	--	+125		
Storage Humidity	Non-condensing	5	--	95	%RH	
Pin Soldering Resistance Temperature	Wave-soldering, 10 seconds	--	--	260	℃	
	Soldering spot is 1.5mm away from case for 10 seconds	--	--	300		
Vibration		10-500Hz, 10G, 0.75mm. along X, Y and Z				
Switching Frequency	PWM operating mode	--	238	--	kHz	
MTBF	Telcordia SR-332@25℃	500	--	--	K hours	

Mechanical Specifications

Housing Material	Aluminum alloy base
Dimensions	63.0*61.0*12.7mm
Weight	112.0g (typ.)
Cooling Method	Forced air cooling or water cooling

Electromagnetic Compatibility (EMC)

EMI	CE	CISPR32/EN55032 CLASS A (see Fig.4 for recommended circuit)		
	RE	CISPR32/EN55032 CLASS A (see Fig.4 for recommended circuit)		
EMS	ESD	IEC61000-4-2	Contact ±6kV/Air ±8kV	perf. Criteria B
	RS	IEC61000-4-3	20V/m	perf. Criteria A
	EFT	IEC61000-4-4	±2KV (see Fig.4 for recommended circuit)	perf. Criteria A
	Surge	IEC61000-4-5	line to line ±2kV (see Fig.4 for recommended circuit)	perf. Criteria B
	CS	IEC61000-4-6	10Vr.m.s	perf. Criteria A

Typical Characteristic Curve-- efficiency curve

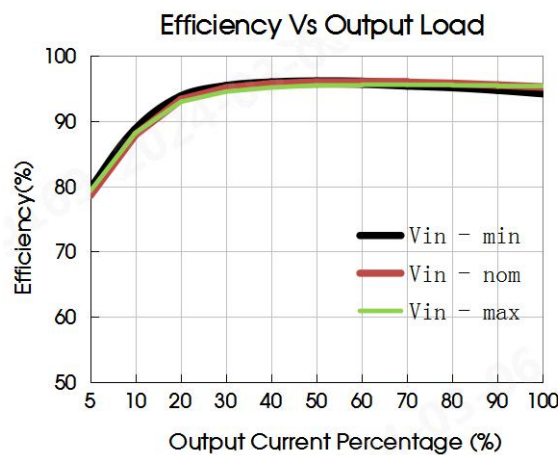

Fig.1

Typical Characteristic Curve-- Temperature derating curve of a metal radiator

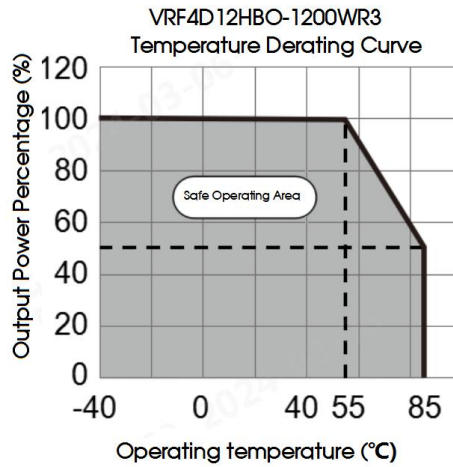

Fig.2

Design Reference

1. Typical application

If the recommended EMC circuit not used, our EMC recommended circuit, the input must be connected with an electrolytic capacitor of at least 82μF to suppress the surge voltage that may be generated at the input end, and the output must be connected with an electrolytic capacitor larger than the minimum capacitive load capacity to stabilize the output working state of the product.

If it is required to further reduce the input and output ripple, the input and output external capacitors Cin and Cout can be increased or a capacitor with a small series equivalent impedance value can be selected, but the capacitance value cannot be greater than the maximum capacitive load of the product.

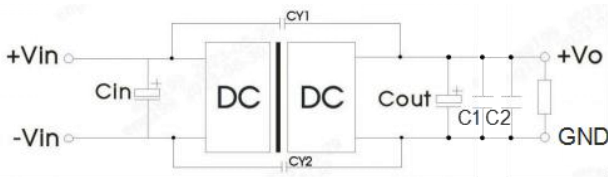

Fig.3

Vout (VDC)	Cin	Cout	CY1/CY2	C1	C2
12	82μF/450V	4000μF/35V	2.2nF/400VAC	1μF/25V	10μF/25V

2. EMC recommended circuit

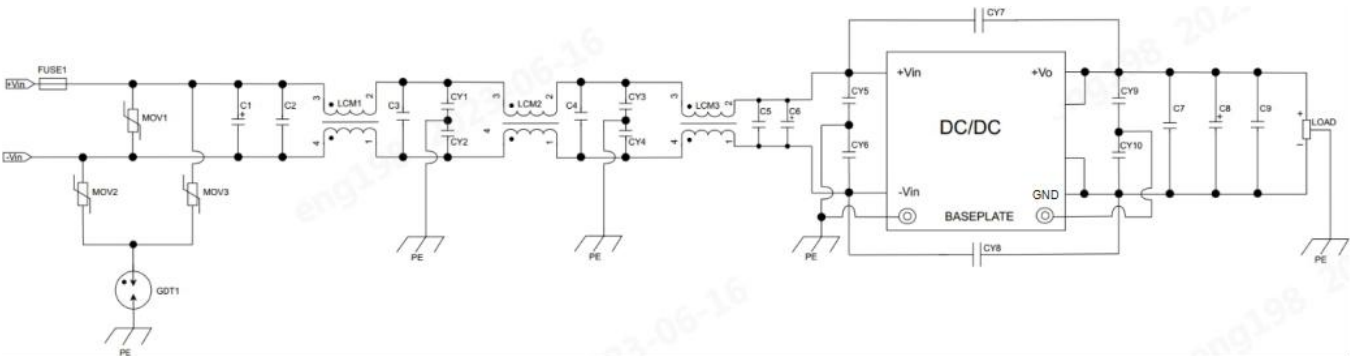

Fig.4

Parameter description:

C1	540uF/500V electrolytic capacitor
C2/C3/C4/C5	2.2uF/450V thin film capacitor
C6	100uF/450V electrolytic capacitor
C7/C9	2.2uF/100V ceramic capacitor
C8	2000uF/63V electrolytic capacitor
LCM1	FL2DN-80-151
LCM2	FL2D-80-752
LCM3	FL2D-80-162
CY1/CY2	4.7 the nF / 400 vac
CY3/CY4	4.7nF/400VAC*2 Connected in parallel
CY5/CY6	2.2nF/400VAC*2 in parallel
CY7/CY8	2.2 the nF / 400 vac
CY9	2.2nF/400VAC+4.7nF/400VAC in parallel
CY10	2.2nF/400VAC*2+4.7nF/400VAC in parallel
FUSE	According to the customer's actual conditions of use,
MOV1/MOV2/MOV3	Recommended: Withstand voltage $\geq 500V$, protection current $\leq 5A$
GDT	14D/561K varistor

For additional information please refer to DC-DC converter application notes on www.mornsun-power.com

Power Management

1. Overview

The product is equipped with PMBus interface. The product enables power management features such as reading and configuration with fewer external components. In addition, the product includes protection features that continuously protect the load from unexpected system failure. The host can continuously monitor the following product parameters: input voltage, output voltage, output current, internal temperature, etc.

The product is shipped with the default configuration, suitable for the maximum range of input voltage, output voltage, load operation. The configuration is stored internally in FLASH. Some power management functions can be reconfigured through the PMBus interface. A detailed description of each command is provided in the appendix at the end of this specification.

Mornsun related software suite can be used to configure and monitor the product through the PMBus interface. For more information, please contact your local Mornsun sales representative.

2. PMBus interface

The product provides a PMBus digital interface that users can configure devices operation as well as monitor input and output voltages, output currents, and device temperature. The product can be compatible with any standard two-wire I2C(master must allow for clock stretching) or PMBus host device. For the communication protocol operation guide, refer to SMBus Specification Version 3.0. In addition, the product is compatible with PMBus version 1.3 and includes an SALERT line to help mitigate bandwidth constraints associated with continuous failure monitoring. The product only supports 100 kHz and 400 kHz bus clock frequency. The PMBus signals, SCL, SDA, and SALERT require passive pull-up resistors as specified in the SMBus specification. To ensure the rise time, a pull-up resistor is needed:

$$\tau = R_p C_p \leq 1\mu s$$

R_p is the pull-up resistance and C_p is the parasitic capacitance of the bus. For details, see the parameters in "PMBus Electrical Specifications". Maximum allowable capacitance of the bus is 400pF. The pull-up resistor should be connected to an external power supply between 2.7-3.8V.

When communicating over PMBus, it is recommended to always use PEC(packet error checking) to increase the robustness of communication.

For the PMBUS communication function, the parameters related to the chip pin are shown in the following table:

System index	Symbol	Involved parameter description	Note
PMBUS communication	SDA	PMBUS Data pin	ESD needs strong handling, 4kV (External ports, high electrostatic protection requirements) Bottom line requirement: 2KV
	SCL	PMBUS Clock pin	
	ADDR	PMBUS Address pin	
	GND	PMBUS Ground reference pin	

3. PMBus addressing

The following address resistor connection diagram and table show the recommended resistor values for the minimum and maximum voltage range of hard-wiring PMBus addresses. ($\pm 1\%$ tolerance resistor is recommended)

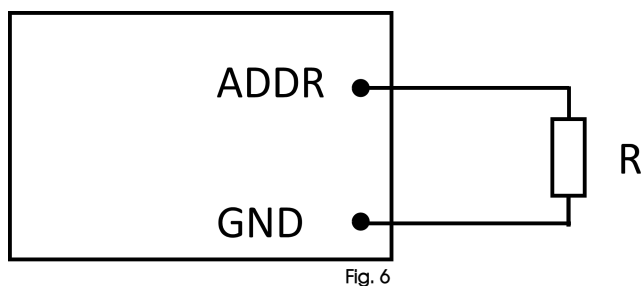

Fig. 6

PMBUS address is calculated as follows:

PMBUS Address(decimal) = SA0 index

The method of obtaining SA0 index is obtained by connecting the external pull-down resistor to the ADDR pin.

SA0 index	R (K Ω)
0x00	Ground connection
0x01	2.26
0x02	4.43
0x03	7.53
0x04	12.31
0x05	20.63
0x06	38.80
0x58	suspended

4. PMBus commands and descriptions

4.1 PMBUS instruction table

Code	Command	Function	Transfer Type	Default Value	
0x01	OPERATION	Switch enable	R/W byte	0x80	
0x03	CLEAR_FAULTS	Clear the fault	W Byte	/	
0x20	VOUT_MODE	Output voltage data format	R Byte	0x15	Ulinear16 N=-11
0x35	VIN_ON	Set starting voltage	R/W Word	0xFABC	350.0V
0x36	VIN_OFF	Set the turn-off voltage	R/W Word	0xFA94	330.0V
0x40	VOUT_OV_FAULT_LIMIT	Output overvoltage fault value	R/W Word	0x7000	14.0V
0x46	IOUT_OC_FAULT_LIMIT	The overcurrent fault value is displayed	R/W Word	0xEBC0	120.0A
0x4F	OT_FAULT_LIMIT	Overtemperature fault value	R/W Word	0xEB70	100.0°C
0x51	OT_WARN_LIMIT	Overtemperature alarm value	R/W Word	0xEAA8	90.0°C
0x55	VIN_OV_FAULT_LIMIT	Enter the overvoltage fault value	R/W Word	0xFB5A	429.0V
0x60	TON_DELAY	Output startup delay time	R/W Word	0xDA80	20.0ms
0x79	STATUS_WORD	Word read total status	R Word		
0x7A	STATUS_VOUT	Read the output voltage status	R Byte		
0x7B	STATUS_IOUT	Read the output current status	R Byte		
0x7C	STATUS_INPUT	Read the input voltage status	R Byte		
0x7D	STATUS_TEMPERATURE	Read temperature status	R Byte		
0x7E	STATUS_CML	Read command/logic status	R Byte		
0x88	READ_VIN	Read input voltage	R Word		
0x8B	READ_VOUT	Read output voltage	R Word		
0x8C	READ_IOUT	Read output current	R Word		
0x8D	READ_TEMPERATURE_1	Reading temperature	R Word		
0x98	PMBus_REVISION	Read the PMBus version	R Byte	0x22	Pmbus1.2
0x99	MFR_ID	Read company name	R/W Block	"MORNSUN"	
0x9A	MFR_MODEL	Reading device type	R/W Block	"LMF1200W"	
0x9B	MFR_REVISION	Read device version	R/W Block	"1.0"	
0x9C	MFR_LOCATION	Read company address	R/W Block	/	
0x9D	MFR_DATE	Read production date	R/W Block	"0508"	
0x9E	MFR_SERIAL	Read serial number	R/W Block	"SN23050000 1"	
0xA0	MFR_VIN_MIN	Read the lower limit of the input voltage	R Word	0xFAD0	360.0V
0xA1	MFR_VIN_MAX	Read the upper limit of the input voltage	R Word	0xFB20	400.0V
0xA4	MFR_VOUT_MIN	Read the lower limit of output voltage	R Word	0x5000	10.0V
0xA5	MFR_VOUT_MAX	Read the upper limit of output voltage	R Word	0x6999	13.2V
0xA6	MFR_IOUT_MIN	Read the upper limit of the output current	R Word	0xEB20	100.0A
0xA7	MFR_POUT_MAX	The upper limit of the output power is read	R Word	0x0A58	1200.0W
0xA8	MFR_TAMBIENT_MAX	Lower limit of reading temperature	R Word	0xEAA8	85.0°C
0xA9	MFR_TAMBIENT_MIN	Lower limit of reading temperature	R Word	0xE580	-40.0°C

5. Instruction details

5.1 OPERATION (0x01)

Transmission type: R/W Byte

Function: on-off control

Function	Description	Value	Function	Description
On-off control	Control equipment output	0x80	Enable	Open output voltage
		0x00	Disable	Close output

5.2 Ctrl_Config (0x02)

Transmission type: W Byte

Features: Ctrl logic control

Function	Description	Value	Function	Description
On-off Config	Control logic Config	0x1F	Negative logic	Hang or connect high level off, connect low level on
		0x1D	Positive logic	Hang or connect high level on, connect low level off

5.3 CLEAR_FAULTS (0x03)

Transmission type: W Byte

Function: Clear all faults and write only

5.4 VOUT_MODE (0x20)

Transmission type: R Byte

Function: Read output voltage data format

Function	Description	Value	Function	Description
Output voltage data format	Read output voltage data format	0x15	Ulinear16, N = -11	Ulinear16 Data format: $Y=X*2^N$

5.5 VIN_ON (0x35)

Transfer type: R/W Word

Function: Set the input voltage start point

Function	Description	Value	Function	Description
Set VIN_ON Threshold	Set the input voltage enable point	340.0V~370.0V	Set the input voltage start point	Data format: Linear11

5.6 VIN_OFF (0x36)

Transfer type: R/W Word

Function: Set the input voltage off breakpoint

Function	Description	Value	Function	Description
Example Set the VIN_OFF threshold	Set the input voltage off breakpoint	300.0V~340.0V	Set the lowest off breakpoint of the input voltage	Data format: Linear11

5.7 VOUT_OV_FAULT_LIMIT (0x40)

Transfer type: R/W Word

Function: Set the input voltage off breakpoint

Function	Description	Value	Function	Description
Set VOUT_OV Threshold	Set the output overvoltage off breakpoint	13.0V~15.0V	Set the output overvoltage off breakpoint	Ulinear16 Data format: Y=X*2^N Ulinear16, N = -11

5.8 IOUT_OC_FAULT_LIMIT (0x46)

Transfer type: R/W Word

Function: Set the output voltage overvoltage fault point

Function	Description	Value	Function	Description
Set the IOUT_OV Threshold.	Set the output overflow shutdown breakpoint	100.0A~120.0A	Set the output overflow shutdown breakpoint	Data format: Linear11

5.9 OT_FAULT_LIMIT (0x4F)

Transfer type: R/W Word

Function: Set the overtemperature fault point

Function	Description	Value	Function	Description
Set OT_FAULT_LIMIT Threshold	Set the overtemperature fault point	30.0°C~120.0°C	Set the temperature off breakpoint	Set the temperature off breakpoint

5.10 OT_WARN_LIMIT (0x51)

Transfer type: R/W Word

Function: Set the overtemperature alarm point

Function	Description	Value	Function	Description
Set OT_FAULT_WARN Threshold	Set an overtemperature warning point	30.0°C~120.0°C	Set an overtemperature warning point	Data format: Linear11

5.11 VIN_OV_FAULT_LIMIT (0x55)

Transfer type: R/W Word

Run the following command to set the input overvoltage fault point

Function	Description	Value	Function	Description
Set the VIN_OV_FAULT Threshold.	Set the input overvoltage switch breakpoint	400.0V~450.0V	Set the input overvoltage switch breakpoint	Set the input overvoltage switch breakpoint

5.12 TON_DELAY (0x60)

Transfer type: R/W Word

Function: Set the start delay time. Output ENABLE to the time when VOUT starts to rise.

Function	Description	Value	Function	Description
Set TON_DELAY Threshold	Set the startup delay	20~100ms	Start-up delay	Data format: Linear11

5.13 STATUS_WORD (0x79)

Transfer type: R Word

Function: Return device status in WORD

Function	Description	Function	Description
VOUT	An output voltage failure or alarm has occurred	1	Fault
		0	trouble-free
IOUT	An output current failure or alarm has occurred	1	Fault
		0	trouble-free
VIN	An input fault or alarm has occurred	1	Fault
		0	trouble-free
VOUT overvoltage	An output overvoltage fault occurred	1	Fault
		0	trouble-free
IOUT Overflows	An output overcurrent fault occurred	1	Fault
		0	trouble-free
VIN undervoltage	An input undervoltage fault occurred	1	Fault
		0	trouble-free
overtemperature	An overtemperature fault occurred	1	Fault
		0	trouble-free
Command/Logic	A command/logic failure has occurred	1	Fault
		0	trouble-free

5.14 STATUS_VOUT (0x7A)

Transmission type: R Byte

Function: Return the output voltage status of the device

Function	Description	Function	Description
Overvoltage fault	Overvoltage fault	1	Fault
		0	trouble-free
Overvoltage alarm	Overvoltage alarm	1	Fault
		0	trouble-free
Undervoltage alarm	Undervoltage alarm	1	Fault
		0	trouble-free
Undervoltage fault	Undervoltage fault	1	Fault
		0	trouble-free
Set voltage alarm	VOUT_COMMAND sets the output voltage to exceed VOUT_MAX	1	Fault
		0	trouble-free
The startup timeout fault occurs	The startup timeout fault occurs	1	Fault
		0	trouble-free
Shutdown timeout alarm	Shutdown timeout alarm	1	Fault
		0	trouble-free

5.15 STATUS_IOUT (0x7B)

Transmission type: R Byte

Function: Return the output current status of the device

Function	Description	Function	Description
Overcurrent fault	Overvoltage fault	1	Fault
		0	trouble-free
Overcurrent and undervoltage faults	Short-circuit fault	1	Fault
		0	trouble-free
Overcurrent alarm	Overcurrent alarm	1	Fault
		0	trouble-free

5.16 STATUS_INPUT (0x7C)

Transmission type: R Byte

Function: Return the input voltage status of the device

Function	Description	Function	Description
Overvoltage fault	Overvoltage fault	1	Fault
		0	trouble-free
Overvoltage alarm	Overvoltage alarm	1	Fault
		0	trouble-free
Undervoltage alarm	Undervoltage alarm	1	Fault
		0	trouble-free
Undervoltage fault	Undervoltage fault	1	Fault
		0	trouble-free

5.17 STATUS_TEMPERATURE (0x7D)

Transmission type: R Byte

Run the following command to return the device temperature status

Function	Description	Function	Description
Overtemperature fault	Overtemperature fault	1	Fault
		0	trouble-free
Overtemperature alarm	Overtemperature alarm	1	Fault
		0	trouble-free
Undertemperature alarm	Undertemperature alarm	1	Fault
		0	trouble-free
Undertemperature fault	Undertemperature fault	1	Fault
		0	trouble-free

5.18 STATUS_CML (0x7E)

Transmission type: R Byte

Run the following command to return the device temperature status

Function	Description	Function	Description
Command failure	Unsupported command	1	Fault
		0	trouble-free
Data failure	Unsupported data	1	Fault
		0	trouble-free
PEC fault	PEC calculation error	1	Fault
		0	trouble-free
Memory failure	Memory failure	1	Fault
		0	trouble-free
Other communication faults	Other communication faults	1	Fault
		0	trouble-free
Logic fault	Logic fault	1	Fault
		0	trouble-free

5.19 READ_VIN (0x88)

Transfer type: R Word

Function: Return input voltage

Function	Format	Unit
Return input voltage	Linear11	V

5.20 READ_VOUT (0x8B)

Transfer type: R Word

Function: Return output voltage

Function	Format	Unit
Return output current	Linear11	A

5.21 READ_IOUT (0x8C)

Transfer type: R Word

Function: Return output current

Function	Format	Unit
Return output current	Linear11	A

5.22 READ_TEMPERATURE_1 (0x8D)

Transfer type: R Word

Function: Return to point 1 to measure temperature

Function	Format	Unit
Go back inside the chip and measure the temperature	Linear11	°C

5.23 PMBUS_REVISION (0x98)

Transmission type: R Byte

Function: Returns the PMBus version supported by this device

Function	Format	Unit
Go back inside the chip and measure the temperature	Linear11	°C

5.24 MFR_ID (0x99)

Transmission type: R Block

Function: Return the company ID

Function	Format
Return company ID	ASCII

5.25 MFR_MODEL (0x9A)

Transmission type: R Block

Function: Return device mode

Function	Format
Return device model ASCII	ASCII

5.26 MFR_REVISION (0x9B)

Transmission type: R Block

Function: Return the device version number

Function	Format
Return the device version number	ASCII

5.27 MFR_LOCATION (0x9C)

Transmission type: R Block

Function: Return the company address

Function	Format
Return the company address	ASCII

5.28 MFR_DATE (0x9D)

Transmission type: R Block

Function: Return the production date

Function	Format
Return the production date	ASCII

5.29 MFR_SERIAL (0x9E)

Transmission type: R Block

Function: Return device serial number

Function	Format
Return device serial number	ASCII

5.30 MFR_VIN_MIN (0xA0)

Transmission type: R world

Function: Read the lower limit of input voltage of the module

Function	Format	Unit
Read the lower limit of input voltage of the module	Linear11	V

5.31 MFR_VIN_MAX (0xA1)

Transmission type: R world

Function: Read the upper limit of input voltage

Function	Format	Unit
Read the upper limit of input voltage	Linear11	V

5.32 MFR_VOUT_MIN (0xA4)

Transmission type: R world

Function: Read the lower limit of DC output voltage

Function	Format	Unit
Read the lower limit of the DC output voltage	Ulinear16 data format: $Y=X*2^N$ Ulinear16, N = -11	V

5.33 MFR_VOUT_MAX (0xA5)

Transmission type: R world

Function: Read DC output voltage upper limit

Function	Format	Unit
Read DC output voltage upper limit	Ulinear16 data format: $Y=X*2^N$ Ulinear16, N = -1	V

5.34 MFR_IOUT_MIN (0xA6)

Transmission type: R world

Function: Read the upper limit of DC output current

Function	Format	Unit
Read the upper DC output current limit	LINEAR11	A

5.35 MFR_POUT_MAX (0xA7)

Transmission type: R world

Function: Read the upper limit of output power

Function	Format	Unit
Read the upper limit of output power	LINEAR11	W

5.36 MFR_TAMBIENT_MAX (0xA8)

Transmission type: R world

Function: Read the upper limit of rated temperature

Function	Format	Unit
Read the upper limit of the rated temperature	LINEAR11	°C

5.37 MFR_TAMBIENT_MIN (0xA9)

Transmission type: R world

Function: Read the lower limit of rated temperature

Function	Format	Unit
Read the lower limit of rated temperature	LINEAR11	°C

Dimensions and Recommended Layout

THIRD ANGLE PROJECTION

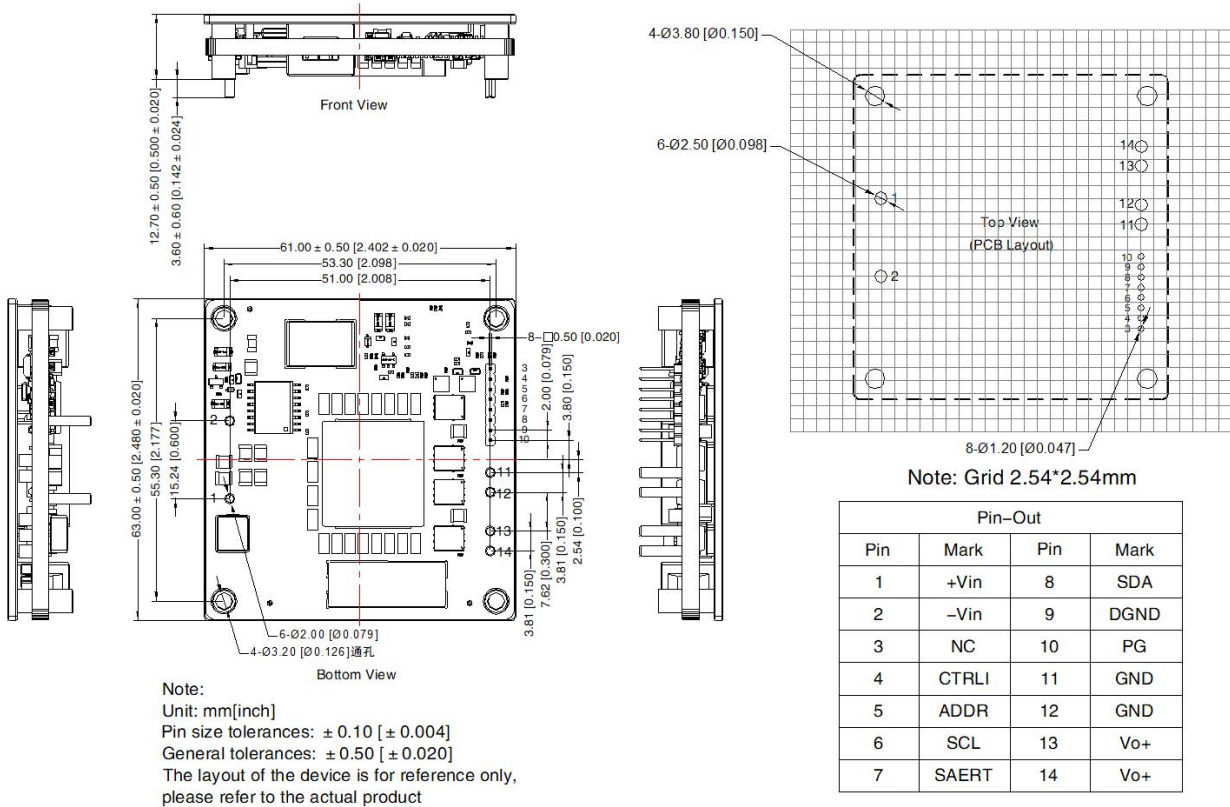

Pin description:

Number	Name	Description
1	+Vin	The input voltage is positive, and the DC input voltage is connected
2	-Vin	If the input voltage is negative, connect to the DC input voltage
3	NC	No functional pin
4	CTRL	Remote control pin, suspended or connected to high level on, connected to low level off, the user can configure through PMBus
5	ADDR	PMBus communication address pin, can be external resistor to determine the local address
6	SCL	PMBus communication clock pin
7	SALERT	PMBus communication fault line function pin
8	SDA	PMBus communication data pin
9	DGND	PMBus communication ground
10	PG	Power good PowerGood function pins
11	GND	Negative output voltage
12	GND	Negative output voltage
13	+Vo	Positive output voltage
14	+Vo	Positive output voltage

Note:

1. For additional information on Product Packaging please refer to www.mornsun-power.com. Packaging bag number: 16022517;
2. If the product works below the minimum required load, it cannot be guaranteed that the performance of the product meets all the performance indicators in this manual. The maximum capacitive load offered were tested at input voltage range and full load;
3. Unless otherwise specified, parameters in this datasheet were measured under the conditions of $T_a=25^{\circ}\text{C}$, humidity < 75%RH with nominal input voltage and rated output load;
4. All index testing methods in this datasheet are based on company corporate standards;
5. We can provide product customization service, please contact our technicians directly for specific information;
6. Products are related to laws and regulations: see "Features" and "EMC";
7. Our products shall be classified according to ISO14001 and related environmental laws and regulations, and shall be handled by qualified units.

Mornsun Guangzhou Science & Technology Co., Ltd.

Address: No. 5, Kehui St. 1, Kehui Development Center, Science Ave., Guangzhou Science City, Huangpu District, Guangzhou, P. R. China
Tel: 86-20-38601850 Fax: 86-20-38601272 E-mail: info@mornsun.cn www.mornsun-power.com