

600W, wide voltage input, isolated voltage regulator single output, DC/DC module power supply



Patent Protection RoHS

FEATURES

- Wide input voltage range: 180-435 VDC
- High efficiency up to 95%
- Enhanced insulation, isolation voltage 3000VAC
- Base plate operating temperature: -40°C to +100°C
- Input under voltage and over voltage protection, output over voltage, over current, short circuit protection, over temperature protection
- Supports parallel current sharing
- Supports the PMBus function
- International standard full brick
- Meet the EN62368 certification standard

VRF3D_FB-600WR3 series output power is 600W, 180-435VDC wide voltage input range, efficiency up to 95%, isolation voltage 3000VAC, housing allowed operating temperature -40°C to +100°C, with input under-voltage/over-voltage protection, output over-voltage/over-current/short circuit protection, over-temperature protection, remote control, output voltage regulation, current sharing, PMBus communication and other functions, through the peripheral to meet the CISPR32/EN55032 CLASS A, widely used in industrial control, communication and other fields.

Selection Guide

Certification	Part No.	Input Voltage (VDC)		Output		Full Load Efficiency ^② (%) Min./Typ.	Min. Capacitive Load (μF)	Max. Capacitive Load (μF)
		Nominal (Range)	Max.	Voltage ^① (VDC)	Current (mA) Max./Min.			
-	VRF3D14FB-600WR3	270 (180 - 435)	435	14	43000/0	93/94	2000	8000
	VRF3D24FB-600WR3			24	25000/0		1500	5000
	VRF3D28FB-600WR3			28	21500/0	94/95	1500	3000
	VRF3D48FB-600WR3			48	12500/0		1000	1500

Note:
 ① In order to ensure the output voltage stability, the output side of the product must be connected with at least one minimum capacitive load. The input and output terminals should be cross-connected with CY1/CY2, which can be designed according to the design reference -1. Typical application circuit;
 ② The above efficiency values are measured at the input nominal voltage and output rated load.

Input Specifications

Item	Operating Conditions	Min.	Typ.	Max.	Unit	
Input Current	Nominal 270VDC input	-	14VDC output voltage, full load	2364	2445	mA
			24/48VDC output voltage, full load	2339	2411	
			28VDC output voltage, full load	2339	2419	
Reflected Ripple Current	Nominal 270VDC input	-	500	800		
Input Impulse Voltage (1sec.max.)		-0.7	-	500	VDC	
Start-up Voltage		-	-	180		
Start-up Current	Nominal 270V input voltage, full load	-	-	3500	mA	
Start-up Time	Nominal input voltage & constant resistance load	-	100	300	ms	
Input Filter		Pi filter				
Hot Plug		Not available				
No-load Power Consumption	Nominal input voltage & constant resistance load	-	16	20	W	
Static Input Power	CTRL connects to TTL high, and DC-DC is off	-	5	8		
Ctrl ^①	Module turn-on	Ctrl pin suspension or TTL low (0-0.8VDC)				
	Module turn-off	Ctrl pin open or pulled high (TTL 4.0-5.0VDC)				
Input Under-voltage Protection		160	170	-	VDC	
Input Over-voltage Protection		-	448	455		

Note:
 ① The voltage of the CTRL pin is relative to the input -VIN; the input voltage of the CTRL pin cannot exceed 5VDC, otherwise it may cause permanent and unrecoverable damage.

Output Specifications

Item	Operating Conditions		Min.	Typ.	Max.	Unit
Output Current Range			0	--	100	%Io
Output Voltage Accuracy	Normal temperature, 0% - 100% load, Rated output voltage		--	±1	±2	%
Linear Regulation	Input voltage ≥200VDC		--	±0.5	±1	
Load Regulation	5% - 100% load		--	±0.4	±1	
Transient Recovery Time	25% load step change, nominal input voltage		--	200	500	μs
Transient Response Deviation ^①			--	±2	±5	%
Temperature Coefficient	Full load		--	--	±0.03	%/°C
Ripple & Noise ^①	Input voltage range, 0% - 100% load	14VDC output	--	250	300	mVp-p
		24/28VDC output	--	150	400	
		48VDC output	--	300	500	
Parallel Current Sharing	Nominal input voltage, single unit load > 50%Io, < 100%Io	Current unbalance degree	--	±3	±10	%Io
		Parallel number	--	--	4	pcs
Trim	See figure 2		70	--	110	%Vo
Sense	Input voltage range		--	--	110	
Over-voltage Protection ^②	Input voltage range, output power range		110	125	140	A
Over-current Protection	Input voltage range	14VDC output	47	51.5	56	
		24VDC output	27.5	30	32.5	
		28VDC output	24	26	28	
		48VDC output	13.5	15	16.5	
Short Circuit Protection	Input voltage range		Hiccup, continuous, self-recover			
Over-temperature Protection	Product surface max. temperature		95	--	115	°C

Note:
 ① Ripple noise test according to the design reference -2. Typical application circuit using measurement method for testing;
 ② Output over-voltage protection mode: latch, recover after restart;
 ③ Input jump voltage 200-435V, slope <30V/ms, output voltage overshoot and undershoot range <±10%.

General Specifications

Item	Operating Conditions	Min.	Typ.	Max.	Unit
Isolation Voltage	Input-output, the test time is 1 minute and the leakage current is less than 20mA	3000	--	--	VAC
	Input-housing, the test time is 1 minute and the leakage current is less than 20mA	2500			
	Output-housing, the test time is 1 minute and the leakage current is less than 20mA	500			
Insulation Resistance	Input-output resistance at 500VDC	100	--	--	MΩ
Isolation Capacitance	Input-output capacitance at 100KHz/0.1V	--	2200	--	pF
Operating Temperature	See fig. 1	-40	--	+100	°C
Storage Temperature		-55	--	+125	
Storage Humidity	Non-condensing	5	--	95	%RH
Pin Soldering Resistance Temperature	Soldering spot is 1.5mm away from case for 10 seconds	--	--	300	°C
Vibration		IEC/EN 61373 Car body Class 1 B			
MTBF	Telcordia SR-332@25°C	1000	--	--	K hours

Mechanical Specifications

Housing Material	Black flame retardant and heat resistant plastic (UL94 V-0), aluminum alloy
Dimensions	116.80 x 61.00 x 12.90 mm
Weight	220.0g (Typ.)
Cooling Method	Natural convection or forced air convection

Electromagnetic Compatibility (EMC)

EMI	CE	CISPR32/EN55032 CLASS A (see Fig.8② for recommended circuit)		
		GJB151B CE102 (see Fig.8② for recommended circuit)		
	RE	CISPR32/EN55032 CLASS A (see Fig.8② for recommended circuit)		
EMS	ESD	IEC61000-4-2	Contact ±6kV/Air ±8kV (see Fig.8① for recommended circuit)	perf. Criteria A
	RS	IEC61000-4-3	10V/m (see Fig.8② for recommended circuit)	perf. Criteria A
	EFT	IEC61000-4-4	±2KV (5KHz,100KHz)(see Fig.8① for recommended circuit)	perf. Criteria A
	Surge	IEC61000-4-5	line to line ±2kV/line to ground ±4kV (see Fig.8① for recommended circuit)	perf. Criteria A
	CS	IEC61000-4-6	10Vr.m.s (see Fig.8② for recommended circuit)	perf. Criteria A

PMBus Electrical specification

Item	Operating Conditions	Min.	Typ.	Max.	Unit
Input Voltage High V_{IH}		2.1	--	3.3	VDC
Input Voltage low level V_{IL}		0	--	0.8	
Output Filling Current I_{OH}		--	--	4	mA
Output Source Current I_{OL}		-4	--	--	
PMBus Operating Frequency	Default operating frequency	--	100	--	Khz

Typical Characteristic Curve

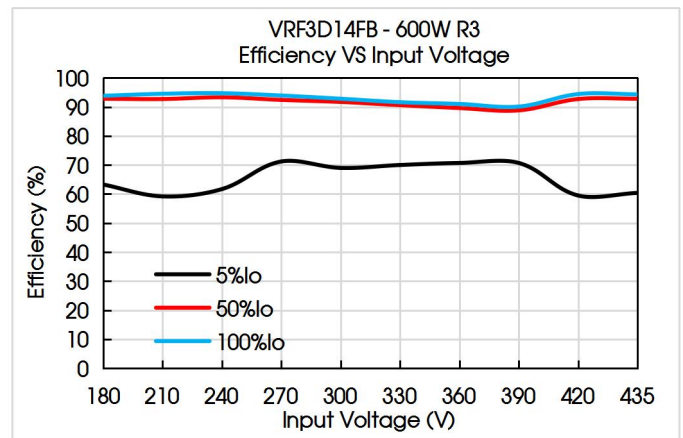
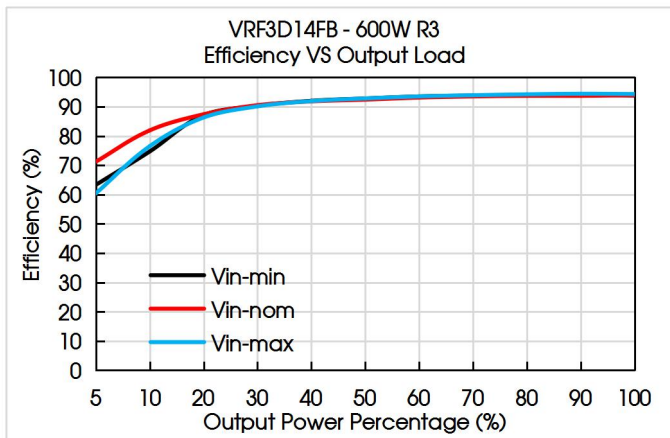
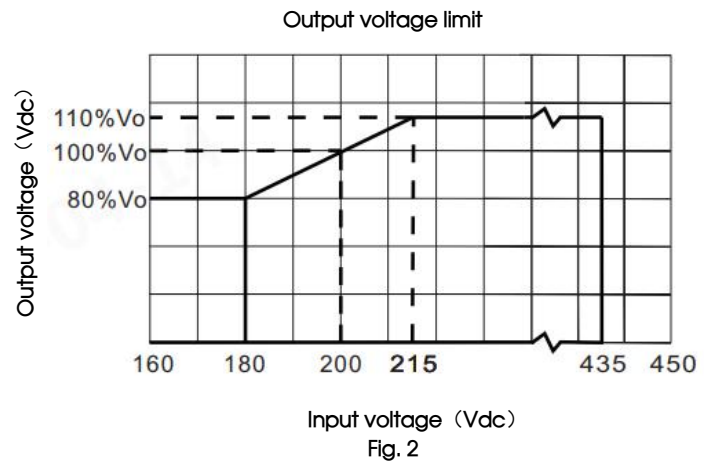
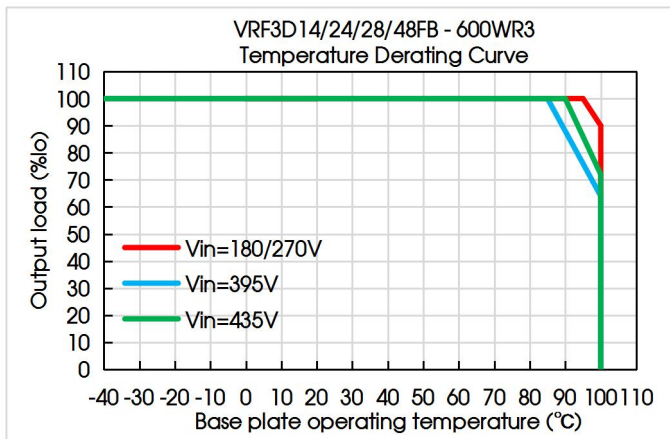

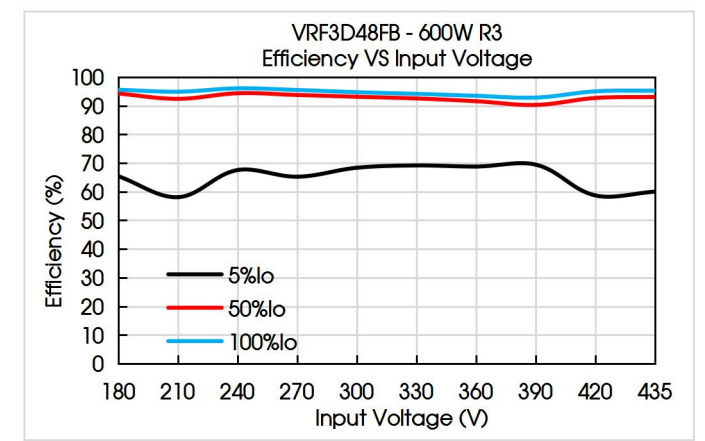
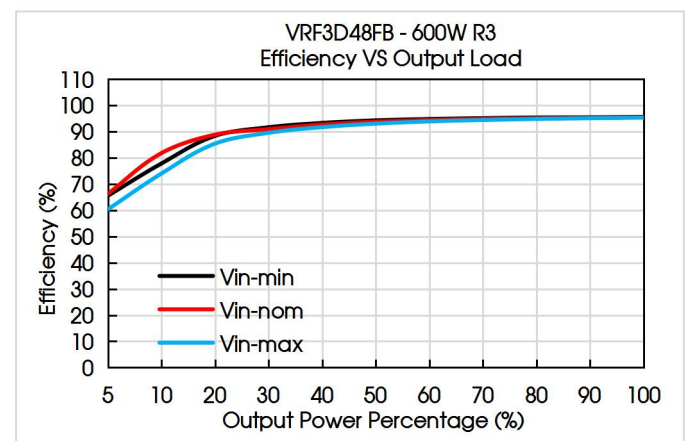
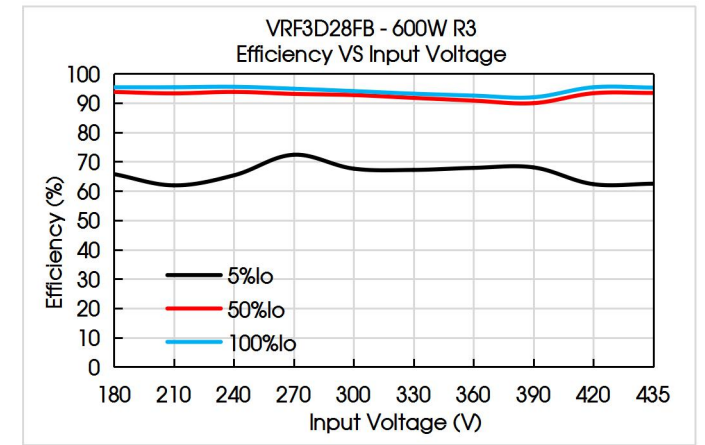
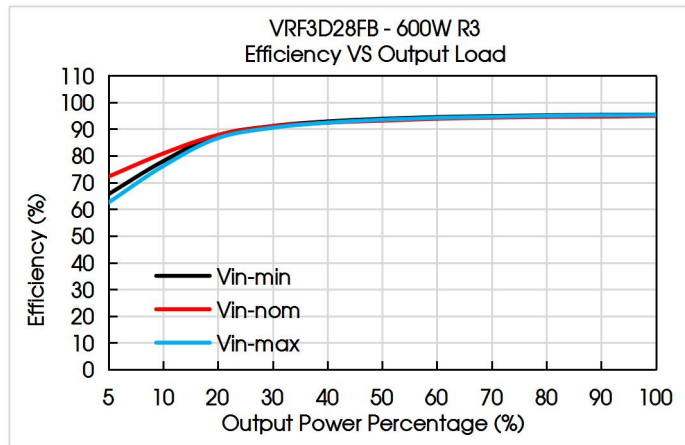
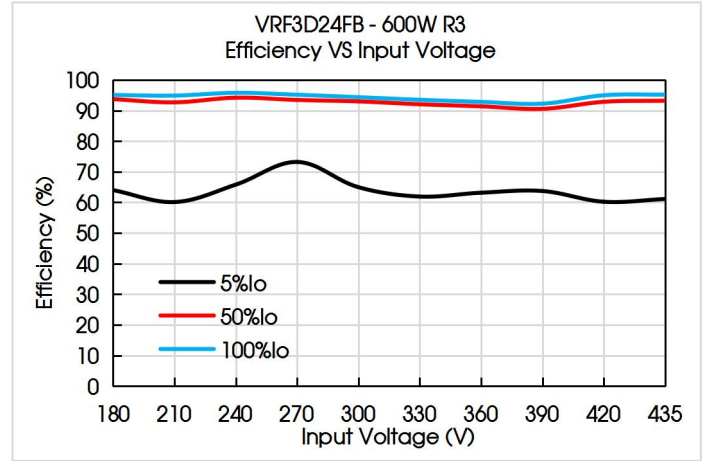
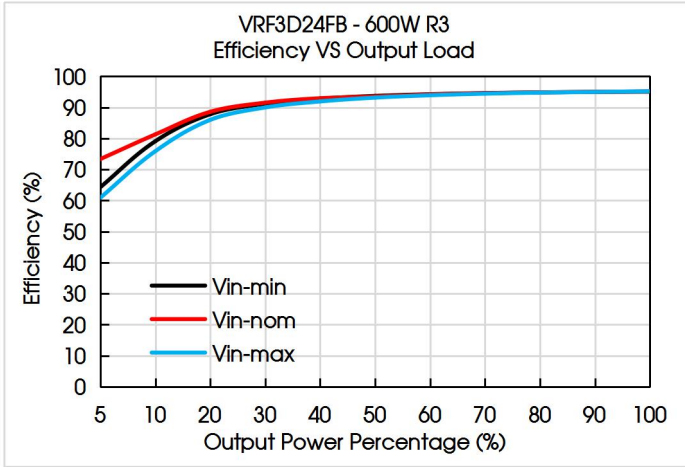

Remote Sense Application

1. Remote Sense Connection if not used

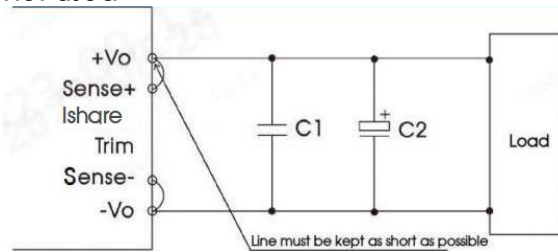

Fig. 3

- Note:
- (1) If the sense function is not used for remote regulation the user must connect the +Sense to +Vo and -Sense to 0V at the DC-DC converter pins and will compensate for voltage drop across pins only.
 - (2) The connections between sense lines and their respective power lines must be kept as short as possible, otherwise they may be picking up noise, interference and/or causing unstable operation of the power module.

2. Remote Sense Connection used for Compensation

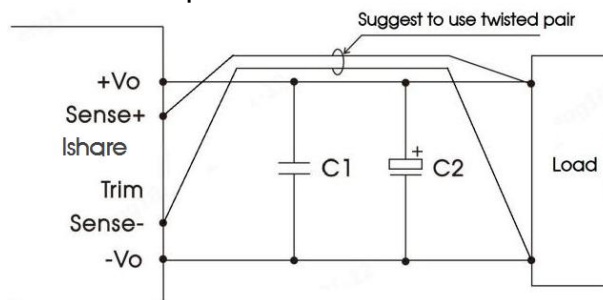

Fig. 4

- Note:
- (1) Using remote sense with long wires may cause unstable output, please contact technical support if long wires must be used.
 - (2) PCB-tracks or cables/wires for Remote Sense must be kept as short as possible. Twisted pair or shielded wires are suggested for remote compensation and must be kept as short as possible.
 - (3) We recommend using adequate cross section for PCB-track layout and/or cables to connect the power supply module to the load in order to keep the voltage drop below 0.3V and to make sure the power supply's output voltage remains within the specified range.
 - (4) Note that large wire impedance may cause oscillation of the output voltage and/or increased ripple. Consult technical support or factory for further advice of sense operation.

Design Reference

1. Typical application

All DC-DC converters of this series are tested before delivery using the recommended circuit shown in Fig. 5. If it is required to further reduce the input and output ripple, the input and output external capacitors Cin and Cout can be increased or a capacitor with a small series equivalent impedance value can be selected, but the capacitance value cannot be greater than the maximum capacitive load of the product.

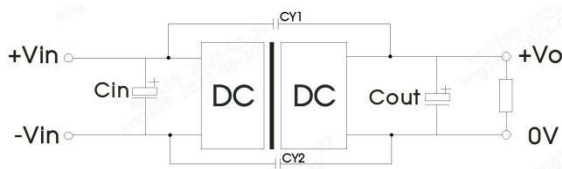

Fig. 5

Capacitance value	Cout (min.)	Cin	CY1/CY2
Output voltage			
14V	2000μF, Withstand voltage ≥ 1.2*Vo	220 μF, Withstand voltage ≥ 500V	2.2nF/ 400VAC
24V	1500μF, Withstand voltage ≥ 1.2*Vo		
28V	1500μF, Withstand voltage ≥ 1.2*Vo		
48V	1000μF, Withstand voltage ≥ 1.2*Vo		

2. Ripple & Noise

All the DC-DC converters of this series are tested before delivery using the recommended circuit shown in Fig. 6.

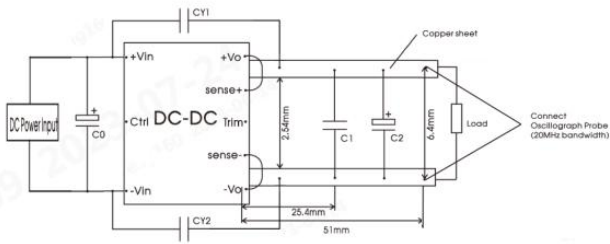

Fig. 6

Capacitors Value Output voltage	C0	C1	C2	CY1/CY2
14VDC			2000µF, Withstand voltage ≥ 1.2*Vo	Y1/2.2nF/ 400VAC
24/28VDC	220µF, Withstand voltage ≥ 500V	1µF, Withstand voltage ≥ 1.2*Vo	1500µF, Withstand voltage ≥ 1.2*Vo	
48VDC			1000µF, Withstand voltage ≥ 1.2*Vo	

Note: C2 capacitors are preferred solid-state capacitors, and the capacity of the capacitor is at least twice the recommended value of C2 when used at low temperatures.

3. Trim Function for Output Voltage Adjustment

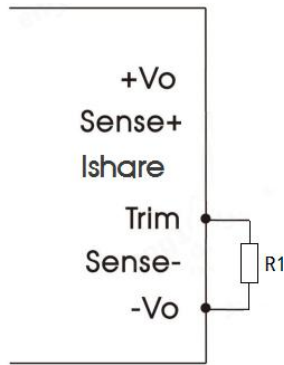

Fig. 7

14V Trim Resistance calculation formula:

$$V_o' = 18.506 * \frac{R1}{R1 + 2} + 0.54$$

24V Trim Resistance calculation formula:

$$V_o' = 31.61 * \frac{R1}{R1 + 2} + 0.8$$

28V Trim Resistance calculation formula:

$$V_o' = 37 * \frac{R1}{R1 + 2} + 1$$

48V Trim Resistance calculation formula:

$$V_o' = 63.3 * \frac{R1}{R1 + 2} + 1.9$$

Note: Vo' is the output voltage value after adding R1.

4. EMC compliance recommended circuit

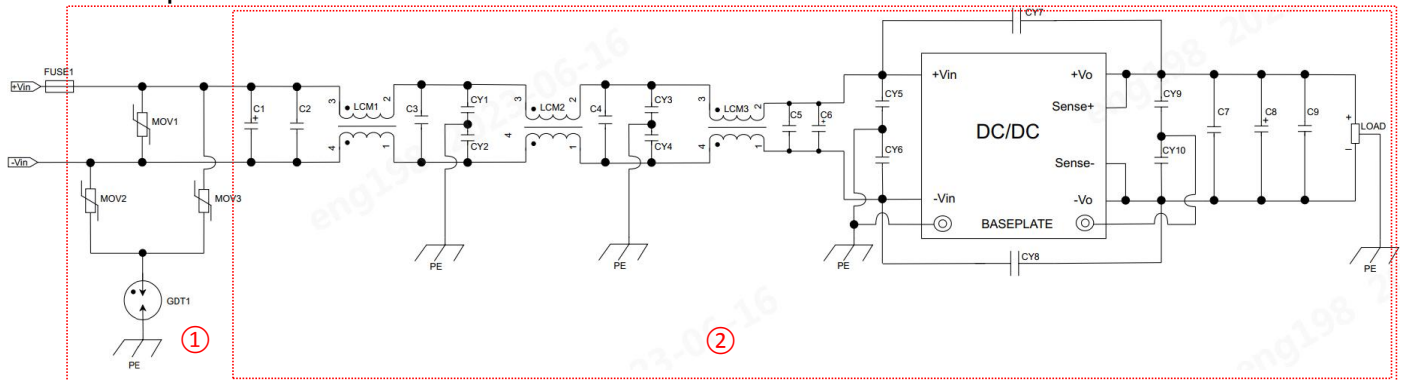

Fig. 8

Device	Parameter description
C1	540uF/500V Electrolytic capacitance
C2/C3/C4/C5	2.2uF/450V Thin film capacitance
C6	150uF/450V Electrolytic capacitance
C7/C9	2.2uF/100V Ceramic capacitor
C8	2000uF/63V Electrolytic capacitance
LCM1	FL2DN-80-151 (N: indicates nickel and zinc)
LCM2	FL2D-80-752
LCM3	FL2D-80-162
CY1/CY2	4.7nF/400VAC
CY3/CY4	4.7nF/400VAC*2 parallel
CY5/CY6	2.2nF/400VAC*2 parallel
CY7/CY8	2.2nF/400VAC
CY9	2.2nF/400VAC+4.7nF/400VAC parallel
CY10	2.2nF/400VAC*2+4.7nF/400VAC parallel
FUSE	The recommended value is less than or equal to 10A
MOV1/MOV2/MOV3	14D/561K varistor
GDT	900V

5. Reflected ripple current test

The input reflected ripple current should be tested according to the peripheral circuit in the figure.

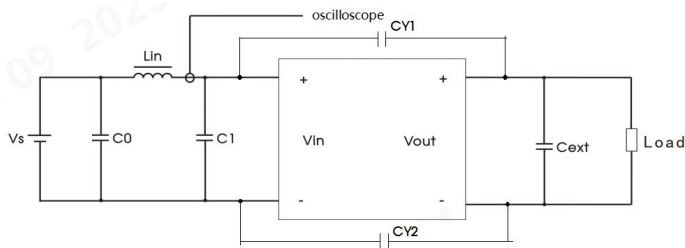

Fig. 9

device	Parameter description
C0	100uF/450V
Lin	4.7uH/10A
C1	200uF/500V
CY1/CY2	2.2nF/400VAC
Cext	Reference application circuitCout

6. The product supports output parallel connection to increase power.

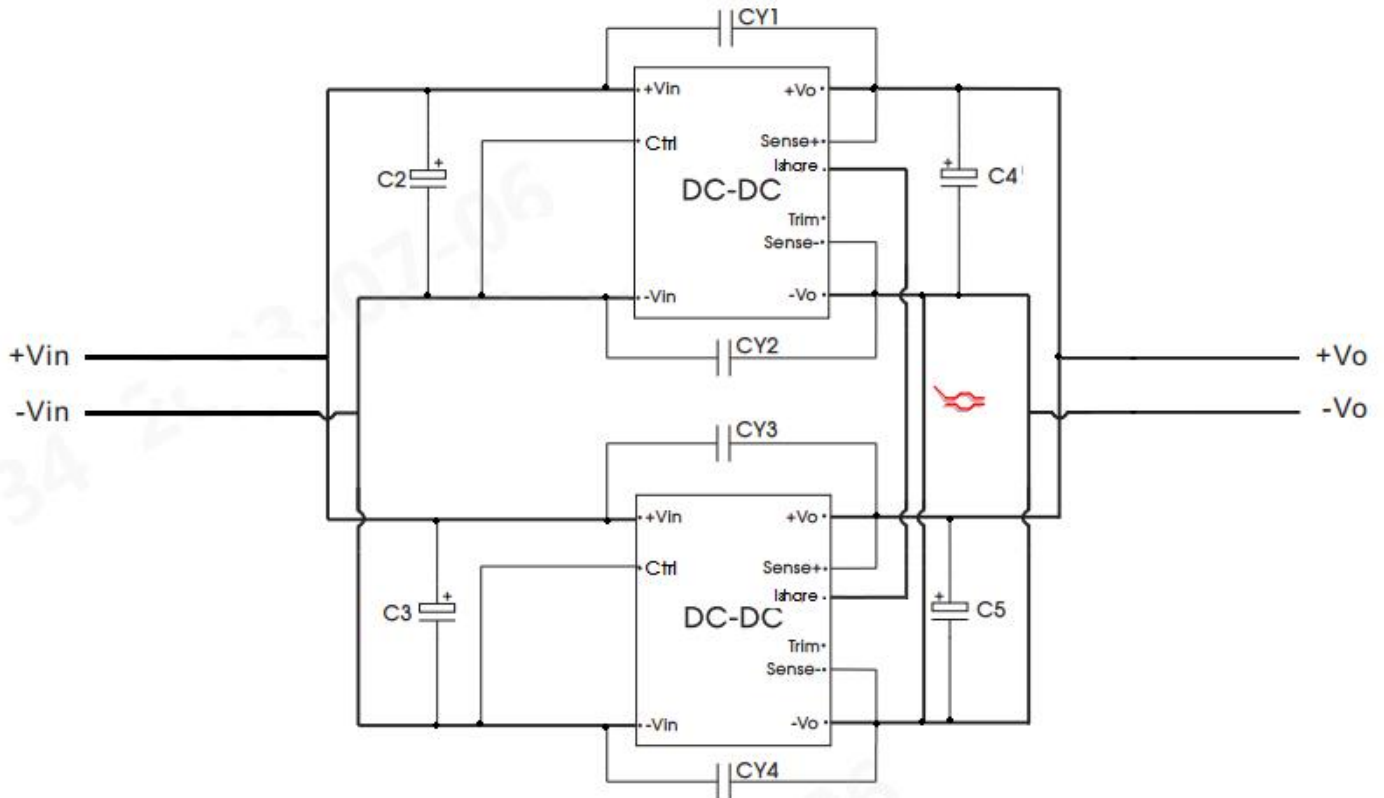

Fig. 10 Parallel current sharing wiring diagram

When the parallel current balancing function is used, ensure that the cable lengths of power modules are equal.

Vout (VDC)	C1/C2/C3	C4/C5/C6	CY1/CY2/CY3/CY4
14	220μF, Withstand voltage ≥ 500V	2000μF, Withstand voltage ≥ 1.2*Vo	2.2nF/400VAC
24		1500μF, Withstand voltage ≥ 1.2*Vo	
28		1500μF, Withstand voltage ≥ 1.2*Vo	
48		1000μF, Withstand voltage ≥ 1.2*Vo	

7. Recommended solutions for thermal testing

In the process of application, the thermal design of the product can be evaluated in combination with the product temperature derating curve, or the stable working interval of the product can be determined by testing the temperature of the thermal test point in Figure 11. When the hot spot temperature (baseplate) is lower than 100° C, it is the stable working range of the product.

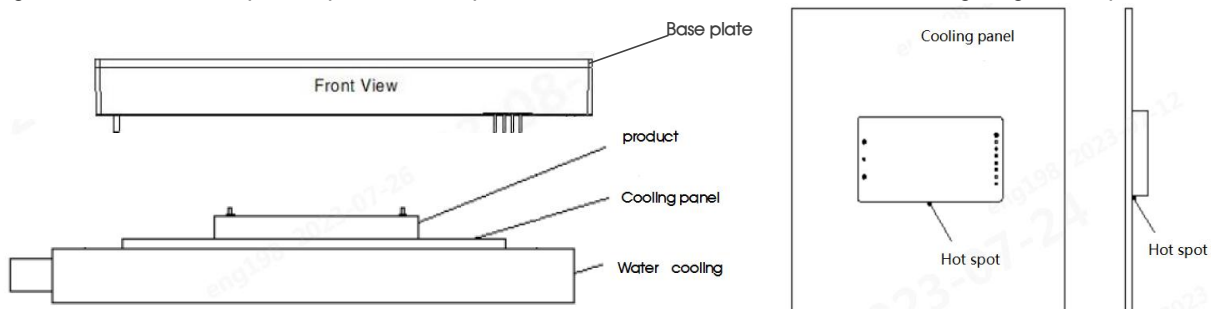

Fig. 11 Product hot spot map

8. For additional information please refer to DC-DC converter application note on www.mornsun.cn

Power Management

1. Overview

The product is equipped with PMBus interface that enables power management such as monitoring or configuration with fewer external components. In addition, the product includes protection to continuously protect the load from unexpected system failures that simultaneously set SALERT pins. The host can continuously monitoring the following product parameters: input voltage, output voltage, output current, duty cycle, internal temperature, etc.

The product is delivered with the default configuration suitable for the maximum range of input voltage, output voltage and load operation. The configuration is stored in an internal Non-Volatile Memory (NVM). All power management functions can be reconfigured through the PMBus interface. A detailed description of each command is provided in the appendix at the end of this specification.

The Mornsun associated software suite can be used to configure and monitor the product through the PMBus interface. Contact your local Mornsun sales representative for more information.

2. PMBus interface

The product provides a PMBus digital interface that users can configure devices operation as well as monitor input and output voltages, output currents, and device temperature. The product can be compatible with any standard two-wire I2C(master must allow for clock stretching) or PMBus host device. For the communication protocol operation guide, refer to SMBus Specification Version 3.0. In addition, the product is compatible with PMBus version 1.3 and includes an SALERT line to help mitigate bandwidth constraints associated with continuous failure monitoring. The product only supports 100 kHz and 400 kHz bus clock frequency. The PMBus signals, SCL, SDA, and SALERT require passive pull-up resistors as specified in the SMBus specification. To ensure the rise time, a pull-up resistor is needed:

$$\tau = R_p C_p \leq 1\mu s$$

Rp is the pull-up resistance and Cp is the parasitic capacitance of the bus. For details, see the parameters in "PMBus Electrical Specifications". Maximum allowable capacitance of the bus is 400pF. The pull-up resistor should be connected to an external power supply between 2.7-3.8V.

When communicating over PMBus, it is recommended to always use PEC(packet error checking) to increase the robustness of communication.

For the PMBUS communication function, the parameters related to the chip pin are shown in the following table:

System index	Symbol	Involved parameter description	Note
PMBUS communication	SDA	PMBUS Data pin	ESD needs strong handling, 4kV (External ports, high electrostatic protection requirements) Bottom line requirement: 2KV
	SCL	PMBUS Clock pin	
	ADDR	PMBUS Address pin	
	GND	PMBUS Ground reference pin	

3. PMBus addressing

The following address resistor connection diagram and table show the recommended resistor values for the minimum and maximum voltage range of hard-wiring PMBus addresses. (±1% tolerance resistor is recommended)

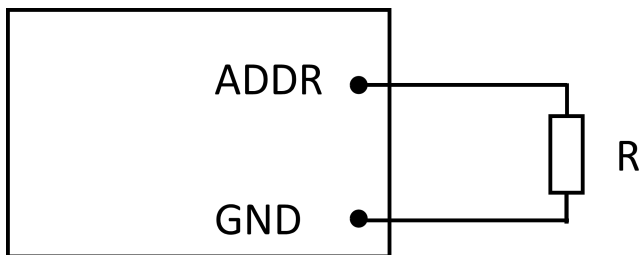

Fig. 12

PMBUS address is calculated as follows:

$$\text{PMBUS Address (decimal)} = \text{SA0 index} + 96$$

The method of obtaining SA0 index is obtained by connecting the external pull-down resistor to the ADDR pin.

If the value exceeds the resistance range, the PMBus address is assigned to 127.

SA0 index	R (KΩ)
0	2.26
1	4.43
2	7.53
3	12.31
4	20.63
5	38.80
31	Leave open

4. PMBus commands and descriptions

4.1 PMBUS instruction table

VRF3D14FB-600WR3						
Code	Command	Function	Transfer Type	Default Value		Data Format
0x01	OPERATION	On-off control	R/W byte	0x80	/	Bit field
0x02	ON_OFF_CONFIG	Switch control configuration	R/W Byte	0x1D	/	Bit field
0x03	CLEAR_FAULTS	Clear the fault	Send Byte	/	/	/
0x11	STORE_DEFAULT_ALL	Save the Settings to NVM	Send Byte	/	/	/
0x12	RESTORE_DEFAULT_ALL	Restore Settings from NVM	Send Byte	/	/	/
0x19	CAPABILITY	Equipment capacity	R Byte	0x80	/	Bit field
0x20	VOUT_MODE	Output voltage data format	R Byte	0x15	/	Bit field
0x35	VIN_ON	Set starting voltage	R/W Word	0xF2C4	177.0V	Linear11
0x36	VIN_OFF	Set the turn-off voltage	R/W Word	0xF2A8	170.0V	Linear11
0x40	VOUT_OV_FAULT_LIMIT	Output overvoltage fault value	R/W Word	0x8800	17.0V	Ulinear16 N = -11
0x46	IOUT_OC_FAULT_LIMIT	The overcurrent fault value is displayed	R/W Word	0xE338	51.5A	Linear11
0x55	VIN_OV_FAULT_LIMIT	Enter the overvoltage fault value	R/W Word	0xFB80	448.0V	Linear11
0x60	TON_DELAY	Output startup delay time	R/W Word	0xDA80	20.0ms	Linear11
0x79	STATUS_WORD	Word read total status	R Word	/	/	Bit field
0x7A	STATUS_VOUT	Read the output voltage status	R Byte	/	/	Bit field
0x7B	STATUS_IOUT	Read the output current status	R Byte	/	/	Bit field
0x7C	STATUS_INPUT	Read the input voltage status	R Byte	/	/	Bit field
0x7D	STATUS_TEMPERATURE	Read temperature status	R Byte	/	/	Bit field
0x7E	STATUS_CML	Read command/logic status	R Byte	/	/	Bit field
0x88	READ_VIN	Read input voltage	R Word	/	/	Bit field
0x8B	READ_VOUT	Read output voltage	R Word	/	/	Bit field
0x8C	READ_IOUT	Read output current	R Word	/	/	Bit field
0x8D	READ_TEMPERATURE_1	Reading temperature	R Word	/	/	Bit field
0x98	PMBus_REVISION	Read the PMBus version	R Byte	0x22	Pmbus1.2	Bit field
0x99	MFR_ID	Read company name	R/W Block	"MORNSUN"	/	ASCII
0x9A	MFR_MODEL	Reading device type	R/W Block	"VRF3D14FB-0600WR3" ^①	/	ASCII
0x9B	MFR_REVISION	Read device version	R/W Block	/	/	ASCII
0x9C	MFR_LOCATION	Read company address	R/W Block	/	/	ASCII
0x9D	MFR_DATE	Read production date	R/W Block	/	/	ASCII
0x9E	MFR_SERIAL	Read serial number	R/W Block	/	/	ASCII
0xA0	MFR_VIN_MIN	Read the lower limit of the input voltage	R Word	0xFAD0	180.0V	Linear11
0xA1	MFR_VIN_MAX	Read the upper limit of the input voltage	R Word	0xFB66	435.0V	Linear11
0xA4	MFR_VOUT_MIN	Read the lower limit of output voltage	R Word	0x4E66	9.8V	Ulinear16 N = -11
0xA5	MFR_VOUT_MAX	Read the upper limit of output voltage	R Word	0x7B33	15.4V	Ulinear16 N = -11
0xA6	MFR_IOUT_MIN	Read the upper limit of the output current	R Word	0xEAB0	43.0A	Linear11
0xA7	MFR_POUT_MAX	The upper limit of the output power is read	R Word	0x0258	600.0W	Linear11
0xA8	MFR_TAMBIENT_MAX	Upper reading temperature	R Word	0xEAA8	85.0°C	Linear11
0xA9	MFR_TAMBIENT_MIN	Lower limit of reading temperature	R Word	0xE580	-40.0°C	Linear11

Note: ① Product model "VRF3D14FB-600WR3"

VRF3D24FB-600WR3

Code	Command	Function	Transfer Type	Default Value		Data Format
0x01	OPERATION	On-off control	R/W byte	0x80	/	Bit field
0x02	ON_OFF_CONFIG	Switch control configuration	R/W Byte	0x1D	/	Bit field
0x03	CLEAR_FAULTS	Clear the fault	Send Byte	/	/	/
0x11	STORE_DEFAULT_ALL	Save the Settings to NVM	Send Byte	/	/	/
0x12	RESTORE_DEFAULT_ALL	Restore Settings from NVM	Send Byte	/	/	/
0x19	CAPABILITY	Equipment capacity	R Byte	0x80	/	Bit field
0x20	VOUT_MODE	Output voltage data format	R Byte	0x15	/	Bit field
0x35	VIN_ON	Set starting voltage	R/W Word	0xF2C4	177.0V	Linear11
0x36	VIN_OFF	Set the turn-off voltage	R/W Word	0xF2A8	170.0V	Linear11
0x40	VOUT_OV_FAULT_LIMIT	Output overvoltage fault value	R/W Word	0xE666	28.8V	Ulinear16 N = -11
0x46	IOUT_OC_FAULT_LIMIT	The overcurrent fault value is displayed	R/W Word	0xDBC0	30.0A	Linear11
0x55	VIN_OV_FAULT_LIMIT	Enter the overvoltage fault value	R/W Word	0xFB80	448.0V	Linear11
0x60	TON_DELAY	Output startup delay time	R/W Word	0xDA80	20.0ms	Linear11
0x79	STATUS_WORD	Word read total status	R Word	/	/	Bit field
0x7A	STATUS_VOUT	Read the output voltage status	R Byte	/	/	Bit field
0x7B	STATUS_IOUT	Read the output current status	R Byte	/	/	Bit field
0x7C	STATUS_INPUT	Read the input voltage status	R Byte	/	/	Bit field
0x7D	STATUS_TEMPERATURE	Read temperature status	R Byte	/	/	Bit field
0x7E	STATUS_CML	Read command/logic status	R Byte	/	/	Bit field
0x88	READ_VIN	Read input voltage	R Word	/	/	Bit field
0x8B	READ_VOUT	Read output voltage	R Word	/	/	Bit field
0x8C	READ_IOUT	Read output current	R Word	/	/	Bit field
0x8D	READ_TEMPERATURE_1	Reading temperature	R Word	/	/	Bit field
0x98	PMBus_REVISION	Read the PMBus version	R Byte	0x22	Pmbus1.2	Bit field
0x99	MFR_ID	Read company name	R/W Block	"MORNSUN"	/	ASCII
0x9A	MFR_MODEL	Reading device type	R/W Block	"VRF3D24FB-0600WR3" ^①	/	ASCII
0x9B	MFR_REVISION	Read device version	R/W Block	/	/	ASCII
0x9C	MFR_LOCATION	Read company address	R/W Block	/	/	ASCII
0x9D	MFR_DATE	Read production date	R/W Block	/	/	ASCII
0x9E	MFR_SERIAL	Read serial number	R/W Block	/	/	ASCII
0xA0	MFR_VIN_MIN	Read the lower limit of the input voltage	R Word	0xFAD0	180.0V	Linear11
0xA1	MFR_VIN_MAX	Read the upper limit of the input voltage	R Word	0xFB66	435.0V	Linear11
0xA4	MFR_VOUT_MIN	Read the lower limit of output voltage	R Word	0x8666	16.8V	Ulinear16 N = -11
0xA5	MFR_VOUT_MAX	Read the upper limit of output voltage	R Word	0xD333	26.4V	Ulinear16 N = -11
0xA6	MFR_IOUT_MIN	Read the upper limit of the output current	R Word	0xE320	25.0A	Linear11
0xA7	MFR_POUT_MAX	The upper limit of the output power is read	R Word	0x0258	600.0W	Linear11
0xA8	MFR_TAMBIENT_MAX	Upper reading temperature	R Word	0xEAA8	85.0℃	Linear11
0xA9	MFR_TAMBIENT_MIN	Lower limit of reading temperature	R Word	0xE580	-40.0℃	Linear11

Note: ① Product model "VRF3D24FB-600WR3"

VRF3D28FB-600WR3						
Code	Command	Function	Transfer Type	Default Value		Data Format
0x01	OPERATION	On-off control	R/W byte	0x80	/	Bit field
0x02	ON_OFF_CONFIG	Switch control configuration	R/W Byte	0x1D	/	Bit field
0x03	CLEAR_FAULTS	Clear the fault	Send Byte	/	/	/
0x11	STORE_DEFAULT_ALL	Save the Settings to NVM	Send Byte	/	/	/
0x12	RESTORE_DEFAULT_ALL	Restore Settings from NVM	Send Byte	/	/	/
0x19	CAPABILITY	Equipment capacity	R Byte	0x80	/	Bit field
0x20	VOUT_MODE	Output voltage data format	R Byte	0x16	/	Bit field
0x35	VIN_ON	Set starting voltage	R/W Word	0xF2C4	177.0V	Linear11
0x36	VIN_OFF	Set the turn-off voltage	R/W Word	0xF2A8	170.0V	Linear11
0x40	VOUT_OV_FAULT_LIMIT	Output overvoltage fault value	R/W Word	0x8800	34.0V	Ulinear16 N = -10
0x46	IOUT_OC_FAULT_LIMIT	The overcurrent fault value is displayed	R/W Word	0xDB40	26.0A	Linear11
0x55	VIN_OV_FAULT_LIMIT	Enter the overvoltage fault value	R/W Word	0xFB80	448.0V	Linear11
0x60	TON_DELAY	Output startup delay time	R/W Word	0xDA80	20.0ms	Linear11
0x79	STATUS_WORD	Word read total status	R Word	/	/	Bit field
0x7A	STATUS_VOUT	Read the output voltage status	R Byte	/	/	Bit field
0x7B	STATUS_IOUT	Read the output current status	R Byte	/	/	Bit field
0x7C	STATUS_INPUT	Read the input voltage status	R Byte	/	/	Bit field
0x7D	STATUS_TEMPERATURE	Read temperature status	R Byte	/	/	Bit field
0x7E	STATUS_CML	Read command/logic status	R Byte	/	/	Bit field
0x88	READ_VIN	Read input voltage	R Word	/	/	Bit field
0x8B	READ_VOUT	Read output voltage	R Word	/	/	Bit field
0x8C	READ_IOUT	Read output current	R Word	/	/	Bit field
0x8D	READ_TEMPERATURE_1	Reading temperature	R Word	/	/	Bit field
0x98	PMBus_REVISION	Read the PMBus version	R Byte	0x22	Pmbus1.2	Bit field
0x99	MFR_ID	Read company name	R/W Block	"MORNSUN"	/	ASCII
0x9A	MFR_MODEL	Reading device type	R/W Block	"VRF3D28FB-0600WR3" ^①	/	ASCII
0x9B	MFR_REVISION	Read device version	R/W Block	/	/	ASCII
0x9C	MFR_LOCATION	Read company address	R/W Block	/	/	ASCII
0x9D	MFR_DATE	Read production date	R/W Block	/	/	ASCII
0x9E	MFR_SERIAL	Read serial number	R/W Block	/	/	ASCII
0xA0	MFR_VIN_MIN	Read the lower limit of the input voltage	R Word	0xFAD0	180.0V	Linear11
0xA1	MFR_VIN_MAX	Read the upper limit of the input voltage	R Word	0xFB66	435.0V	Linear11
0xA4	MFR_VOUT_MIN	Read the lower limit of output voltage	R Word	0x9CCC	19.6V	Ulinear16 N = -10
0xA5	MFR_VOUT_MAX	Read the upper limit of output voltage	R Word	0xF800	31.0V	Ulinear16 N = -10
0xA6	MFR_IOUT_MIN	Read the upper limit of the output current	R Word	0xE2B0	21.5A	Linear11
0xA7	MFR_POUT_MAX	The upper limit of the output power is read	R Word	0x0258	600.0W	Linear11
0xA8	MFR_TAMBIENT_MAX	Upper reading temperature	R Word	0xEAA8	85.0℃	Linear11
0xA9	MFR_TAMBIENT_MIN	Lower limit of reading temperature	R Word	0xE580	-40.0℃	Linear11

Note: ① Product model "VRF3D28FB-600WR3"

VRF3D48FB-600WR3						
Code	Command	Function	Transfer type	Default Value		Data Format
0x01	OPERATION	On-off control	R/W byte	0x80	/	Bit field
0x02	ON_OFF_CONFIG	Switch control configuration	R/W Byte	0x1D	/	Bit field
0x03	CLEAR_FAULTS	Clear the fault	Send Byte	/	/	/
0x11	STORE_DEFAULT_ALL	Save the Settings to NVM	Send Byte	/	/	/
0x12	RESTORE_DEFAULT_ALL	Restore Settings from NVM	Send Byte	/	/	/
0x19	CAPABILITY	Equipment capacity	R Byte	0x80	/	Bit field
0x20	VOUT_MODE	Output voltage data format	R Byte	0x16	/	Bit field
0x35	VIN_ON	Set starting voltage	R/W Word	0xF2C4	177.0V	Linear11
0x36	VIN_OFF	Set the turn-off voltage	R/W Word	0xF2A8	170.0V	Linear11
0x40	VOUT_OV_FAULT_LIMIT	Output overvoltage fault value	R/W Word	0xE666	57.6V	Ulinear16 N = -10
0x46	IOUT_OC_FAULT_LIMIT	The overcurrent fault value is displayed	R/W Word	0xD3C0	15.0A	Linear11
0x55	VIN_OV_FAULT_LIMIT	Enter the overvoltage fault value	R/W Word	0xFB80	448.0V	Linear11
0x60	TON_DELAY	Output startup delay time	R/W Word	0xDA80	20.0ms	Linear11
0x79	STATUS_WORD	Word read total status	R Word	/	/	Bit field
0x7A	STATUS_VOUT	Read the output voltage status	R Byte	/	/	Bit field
0x7B	STATUS_IOUT	Read the output current status	R Byte	/	/	Bit field
0x7C	STATUS_INPUT	Read the input voltage status	R Byte	/	/	Bit field
0x7D	STATUS_TEMPERATURE	Read temperature status	R Byte	/	/	Bit field
0x7E	STATUS_CML	Read command/logic status	R Byte	/	/	Bit field
0x88	READ_VIN	Read input voltage	R Word	/	/	Bit field
0x8B	READ_VOUT	Read output voltage	R Word	/	/	Bit field
0x8C	READ_IOUT	Read output current	R Word	/	/	Bit field
0x8D	READ_TEMPERATURE_1	Reading temperature	R Word	/	/	Bit field
0x98	PMBus_REVISION	Read the PMBus version	R Byte	0x22	Pmbus1.2	Bit field
0x99	MFR_ID	Read company name	R/W Block	"MORNSUN"	/	ASCII
0x9A	MFR_MODEL	Reading device type	R/W Block	"VRF3D48FB-0600WR3" ^①	/	ASCII
0x9B	MFR_REVISION	Read device version	R/W Block	/	/	ASCII
0x9C	MFR_LOCATION	Read company address	R/W Block	/	/	ASCII
0x9D	MFR_DATE	Read production date	R/W Block	/	/	ASCII
0x9E	MFR_SERIAL	Read serial number	R/W Block	/	/	ASCII
0xA0	MFR_VIN_MIN	Read the lower limit of the input voltage	R Word	0xFAD0	180.0V	Linear11
0xA1	MFR_VIN_MAX	Read the upper limit of the input voltage	R Word	0xFB66	435.0V	Linear11
0xA4	MFR_VOUT_MIN	Read the lower limit of output voltage	R Word	0x8666	33.6V	Ulinear16 N = -10
0xA5	MFR_VOUT_MAX	Read the upper limit of output voltage	R Word	0xD333	52.8V	Ulinear16 N = -10
0xA6	MFR_IOUT_MIN	Read the upper limit of the output current	R Word	0xDB20	12.5A	Linear11
0xA7	MFR_POUT_MAX	The upper limit of the output power is read	R Word	0x0258	600.0W	Linear11
0xA8	MFR_TAMBIENT_MAX	Upper reading temperature	R Word	0xEAA8	85.0°C	Linear11
0xA9	MFR_TAMBIENT_MIN	Lower limit of reading temperature	R Word	0xE580	-40.0°C	Linear11

Note: ① Product model "VRF3D48FB-600WR3"

5. Instruction details

5.1 OPERATION (0x01)

Transmission type: R/W Byte

Function: on-off control

Bit	Function	Bit Value	Description	Default Settings		Note
7	Control equipment output	1	Open output	1	0x80	/
		0	Close output			
6:0	/	0000000	Reserved bit	0000000		

5.2 ON_OFF_CONFIG (0x02)

Transmission type: R/W Byte

Function: Switch control configuration

Bit	Function	Bit Value	Description	Default Settings		Note							
7:5	/	000	Reserved bit	000									
4	OPERATION mode Settings that the control module responds to CTRL and PMBUS controls OPERATION Enable	1	After the operating conditions are met, the system starts only after receiving the CTRL and OPERATION commands	1	0x1D	Can set: 0x1D; 0x1F;							
		0	Regardless of the status of the CTRL pin, the module works if the normal working conditions are met.										
3	CTRL enable Primary side CTRL controls polarity	1	Enable the OPERATION command to start output	1	0x1D		Can set: 0x1D; 0x1F;						
		0	Do not use the OPERATION command to start output										
2	The turn-off mode controlled by CTRL on the primary side OPERATION mode Settings that the control module responds to CTRL and PMBUS controls	1	The original CTRL line was enabled to control output	1				0x1D	Can set: 0x1D; 0x1F;				
		0	Disable the original control line to control the output										
1	OPERATION Enable CTRL enable	1	High level enables output	0						0x1D	Can set: 0x1D; 0x1F;		
		0	Low level enables output										
0	Primary side CTRL controls polarity	1	Close output immediately	1								0x1D	Can set: 0x1D; 0x1F;
		0	Use programmable shutdown delay/fall time										

5.3 CLEAR_FAULTS (0x03)

Transmission type: Send Byte

Run the following command to clear all faults

Note: If the module fault persists, the fault bit is still set.

5.4 STORE_DEFAULT_ALL (0x11)

Transmission type: Send Byte

Function: Save Settings to NVM

Note: There are operational risks.

- ① Do not execute the command more than once;
- ② Keep the system stable during execution;
- ③ After executing this command, it is recommended to restart the module after making sure that the power is completely off.

5.5 RESTORE_DEFAULT_ALL (0x12)

Transmission type: Send Byte

Function: Restore factory Settings from NVM

Note: There are operational risks.

- ① Do not execute the command more than once;
- ② After the shutdown command is executed, the command is executed when the system is shut down;
- ③ After executing this command, it is necessary to make sure that the power is completely off before restarting the module.

5.6 CAPABILITY (0x19)

Transmission type: R Byte

Function: Device capability

Bit	Function	Bit Value	Description	Default Settings		Note
7	PEC function Bus speed	1	Support	1		
		0	Nonsupport			
6:5	SALERT Fault line function Number format AVSBus function	00	The maximum support is 100kHz	00		
		01	The maximum support is 400kHz			
		10	Supports a maximum of 1MHz			
4	PEC function Bus speed	1	The device does have a SALERT pin and supports the SMBus alert corresponding protocol	0	0x80	/
		0	The device does not have a SALERT pin and does not support the SMBus alert corresponding protocol			
3	SALERT Fault line function Number format	1	The number format is IEEE half-precision floating point	0		
		0	The digital format is: Linear11,			
2	AVSBus function	1	Ulinear16, Slinear16 or one of the direct numbers	0		
		0	Support			
1:0	/	00	Nonsupport	00		

5.7 VOUT_MODE (0x20)

Transmission type: R Byte

Function: Read output voltage data format

Bit	Function	Bit Value	Description	Default Settings		Note
7:5	Data formatting	000	Output voltage related commands support only Ulinear16 format	000	0x15 N = -11	VRF3D14FB-0600WR3
4:0	n-value	10101	Ulinear16 Indicates the N value of data	10101		
7:5	Data formatting	000	Output voltage related commands support only Ulinear16 format	000	0x15 N = -11	VRF3D24FB-0600WR3
4:0	n-value	10101	Ulinear16 Indicates the N value of data	10101		
7:5	Data formatting	000	Output voltage related commands support only Ulinear16 format	000	0x16 N = -10	VRF3D28FB-0600WR3
4:0	n-value	10110	Ulinear16 Indicates the N value of data	10110		
7:5	Data formatting	000	Output voltage related commands support only Ulinear16 format	000	0x16 N = -10	VRF3D48FB-0600WR3
4:0	n-value	10110	Ulinear16 Indicates the N value of data	10110		

5.8 VIN_ON (0x35)

Transfer type: R/W Word

Function: Set the input voltage start point

Bit	Function	Format	Units	Default Settings		Range limit	Note
15:0	Example Set the VIN_ON threshold	Linear11	V	0xF2C8	178.0	177.0-200.0	/

5.9 VIN_OFF (0x36)

Transfer type: R/W Word

Function: Set the input voltage off breakpoint

Bit	Function	Format	Units	Default Settings		Range limit	Note
15:0	Example Set the VIN_ON threshold	Linear11	V	0xF2A8	170.0	170.0-175.0	/

5.10 VOUT_OV_FAULT_LIMIT (0x40)

Transfer type: R/W Word

Function: Set the input voltage off breakpoint

Bit	Function	Format	Units	Default Settings		Range limit	Note
15:0	Example Set the output overvoltage fault threshold	Ulinear16	V	0x8800	17.0	15.0-18.0	VRF3D14FB-0600WR3
15:0	Example Set the output overvoltage fault threshold	Ulinear16	V	0xE666	28.8	26.0-30.0	VRF3D24FB-0600WR3
15:0	Example Set the output overvoltage fault threshold	Ulinear16	V	0x8800	34.0	30.0-34.0	VRF3D28FB-0600WR3
15:0	Example Set the output overvoltage fault threshold	Ulinear16	V	0xE666	57.6	52.0-60.0	VRF3D48FB-0600WR3

5.11 IOUT_OC_FAULT_LIMIT (0x46)

Transfer type: R/W Word

Function: Set the output voltage overvoltage fault point

Bit	Function	Format	Units	Default Settings		Range limit	Note
15:0	Example Set the output overcurrent fault threshold	Linear11	A	0xE338	51.5	21.5-52.0	VRF3D14FB-0600WR3
15:0	Example Set the output overcurrent fault threshold	Linear11	A	0xDBC0	30.0	12.5-30.0	VRF3D24FB-0600WR3
15:0	Example Set the output overcurrent fault threshold	Linear11	A	0xDB40	26.0	10.75-26.0	VRF3D28FB-0600WR3
15:0	Example Set the output overcurrent fault threshold	Linear11	A	0xD3C0	15.0	6.25-16.0	VRF3D48FB-0600WR3

5.12 VIN_OV_FAULT_LIMIT (0x55)

Transfer type: R/W Word

Function: Set the input voltage overvoltage fault point

Bit	Function	Format	Units	Default Settings		Range limit	Note
15:0	Example Set the input overvoltage threshold	Linear11	V	0xFB80	448.0	420.0-455.0	/

5.13 TON_DELAY (0x60)

Transfer type: R/W Word

Function: Set the start delay time. Output ENABLE to the time when VOUT starts to rise. This delay is directly equivalent to the delay established between the output signal and the output voltage enabled by the "Ctrl, OPERATION" function. This delay is superimposed in the startup delay time when the input power is restarted or the system fails to work.

Bit	Function	Format	Units	Default Settings		Range limit	Note
15:0	Example Set the TON_DELAY threshold	Linear11	ms	20.0	0xDA80	20.0-50.0	/

5.14 STATUS_WORD (0x79)

Transfer type: R Word

Function: Use WORD to return the faulty device status.

High Byte						
Bit	Function	Bit Value	Description	Default Settings		Note
7	VOUT fault or alarm	1	An output voltage failure or alarm has occurred	/	/	/
	IOUT fault or alarm	0	No output voltage failure or alarm occurred			
6	VIN failure or alarm	1	An output current failure or alarm has occurred	/	/	/
	VOUT fault or alarm	0	No output current failure or alarm occurred			
5	IOUT fault or alarm	1	An input voltage failure or alarm has occurred	/	/	/
		0	No input voltage failure or alarm occurred			
4:0	/	/	Reserved bit	/	/	/

Low Byte						
Bit	Function	Bit Value	Description	Default Settings		Note
7:6	/	00	Reserved bit	/	/	/
5	VOUT overvoltage fault	1	An output overvoltage fault occurred	/	/	/
	IOUT overcurrent fault	0	No output overvoltage fault occurs			
4	The VIN undervoltage is faulty	1	An output overcurrent fault occurred	/	/	/
	Temperature fault or alarm	0	No output overcurrent fault occurs			
3	The command is faulty or logic is faulty	1	The input voltage undervoltage fault occurred	/	/	/
	VOUT overvoltage fault	0	No input voltage undervoltage fault occurs			
2	IOUT overcurrent fault	1	An overtemperature fault or alarm has occurred	/	/	/
	The VIN undervoltage is faulty	0	No temperature failure or alarm has occurred			
1	Temperature fault or alarm	1	A command logic failure occurred	/	/	/
		0	No command logic fault occurs			
0	/	/	Reserved bit	/	/	/

5.15 STATUS_VOUT (0x7A)

Transfer type: R Byte

Function: Return the output voltage status of the device.

Bit	Function	Bit Value	Description	Default Settings		Note
7	VOUT overvoltage fault	1	An output voltage failure has occurred	/	/	/
		0	No output voltage failure occurred			
6:0	/	/	Reserved bit	/	/	/

5.16 STATUS_IOUT (0x7B)

Transfer type: R Byte

Function: Return the output current status of the device.

Bit	Function	Bit Value	Description	Default Settings		Note
7	IOUT overcurrent fault	1	An output current failure occurred	/	/	/
		0	No output current fault occurs			
6:0	/	/	Reserved bit	/	/	/

5.17 STATUS_INPUT (0x7C)

Transfer type: R Byte

Function: Return the input voltage status of the device.

Bit	Function	Bit Value	Description	Default Settings		Note
7	VIN overvoltage fault /	1	An input overvoltage fault occurred	/	/	/
		0	No input overvoltage fault occurs			
6:5	The VIN undervoltage is faulty	/	Reserved bit	/	/	/
4	VIN overvoltage fault	1	An input undervoltage fault occurred	/	/	/
		0	No input undervoltage fault occurs			
3:0	/	/	Reserved bit	/	/	/

5.18 STATUS_TEMPERATURE (0x7D)

Transfer type: R Byte

Feature: Returns the device temperature status.

Bit	Function	Bit Value	Description	Default Settings		Note
7	Overtemperature fault	1	An overtemperature fault occurred	/	/	/
		0	No overtemperature fault occurs			
6:5	/	/	Reserved bit	/	/	/

5.19 STATUS_CML (0x7E)

Transfer type: R Byte

Feature: Returns the device temperature status.

Bit	Function	Bit Value	Description	Default Settings		Note
7	Command failure Data failure	1	Unsupported command	/	/	/
		0	Support command			
6	PEC fault Command failure	1	Unsupported data	/	/	/
		0	Supporting data			
5	Data failure	1	PEC calculation error	/	/	/
		0	PEC calculation is correct			
4:0	/	/	Reserved bit	/	/	/

5.20 READ_VIN (0x88)

Transfer type: R Word

Function: Return the input voltage value.

Bit	Function	Format	Unit	Note
15:0	Returns the module input voltage value	Linear11	V	/

5.21 READ_VOUT (0x8B)

Transfer type: R Word

Function: Return the output voltage value.

Bit	Function	Format	Unit	Note
15:0	Return the output voltage of the module	Ulinear16	V	/

5.22 READ_IOUT (0x8C)

Transfer type: R Word

Function: Return output current value.

Bit	Function	Format	Unit	Note
15:0	Returns the module output current value	Linear11	A	/

5.23 READ_TEMPERATURE_1 (0x8D)

Transfer type: R Word

Function: Return module to measure temperature.

Bit	Function	Format	Unit	Note
15:0	Returns the module's measured temperature value	Linear11	°C	/

Dimensions and Recommended Layout

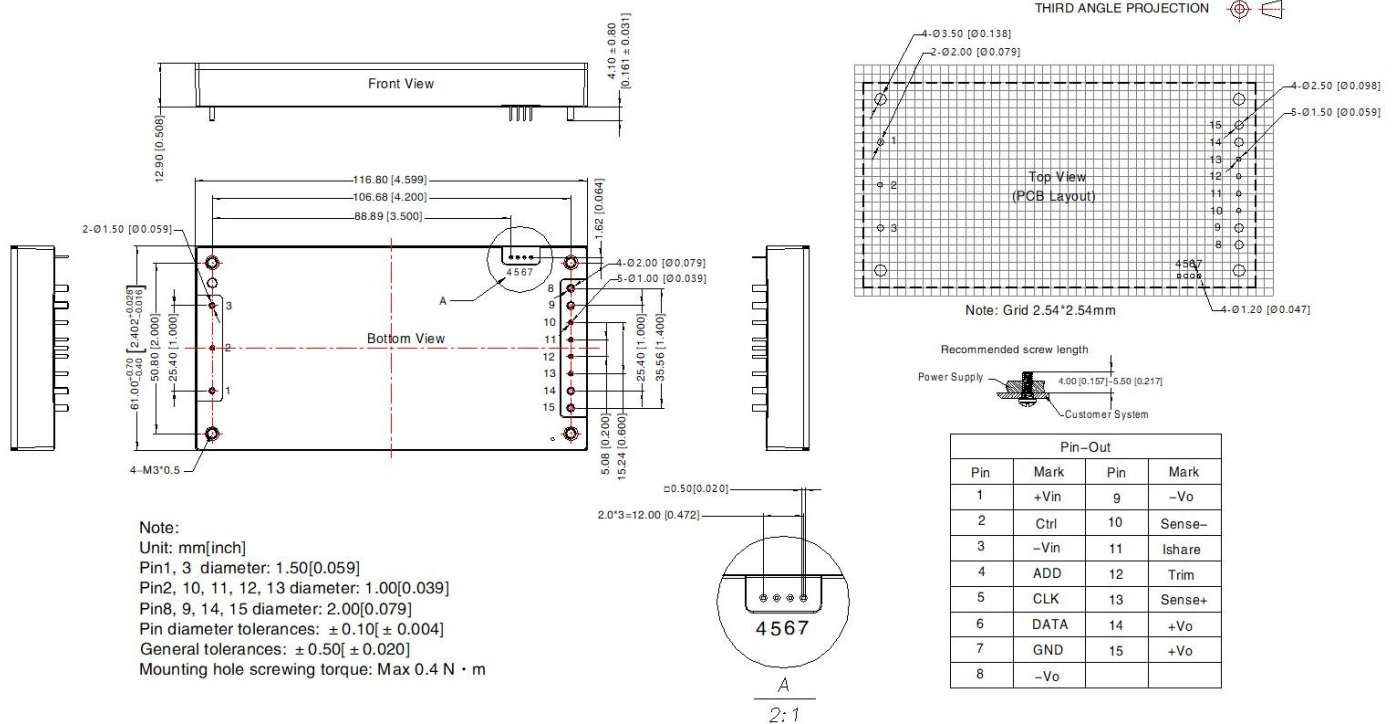

Pin description:

Number	Name	Description
1	+Vin	The input voltage is positive, and the DC input voltage is connected
2	Ctrl	Remote control foot, suspended or connected to low level open, connected to high level off
3	-Vin	If the input voltage is negative, connect to the DC input voltage
4	ADD	PMBus communication address pin, can be external resistor to determine the local address
5	CLK	PMBus communication clock pin
6	DATA	PMBus communication data pin
7	GND	PMBus communication ground

8	-Vo	Negative output voltage
9	-Vo	Negative output voltage
10	Sense-	The output voltage is compensated by the remote side, and can be connected to the load side when compensation is required. When no compensation is required, it can be shorted with -Vo
11	Ishare	Flow sharing pin for parallel flow sharing
12	Trim	The output voltage regulation pin can be used to up and down the output voltage by external voltage
13	Sense+	The output voltage is compensated positively at the remote end, and can be connected to the load end when compensation is required, and +Vo short-circuited when no compensation is required
14	+Vo	Positive output voltage
15	+Vo	Positive output voltage

Note:

1. For additional information on Product Packaging please refer to www.mornsun-power.com. Packaging bag number: 58210118;
2. If the product works below the minimum required load, it cannot be guaranteed that the performance of the product meets all the performance indicators in this manual. The maximum capacitive load offered were tested at input voltage range and full load;
3. Unless otherwise specified, parameters in this datasheet were measured under the conditions of $T_a=25^{\circ}\text{C}$, humidity<75%RH with nominal input voltage and rated output load;
4. All index testing methods in this datasheet are based on company corporate standards;
5. We can provide product customization service, please contact our technicians directly for specific information;
6. Products are related to laws and regulations: see "Features" and "EMC";
7. Our products shall be classified according to ISO14001 and related environmental laws and regulations, and shall be handled by qualified units.

Mornsun Guangzhou Science & Technology Co., Ltd.

Address: No. 5, Kehui St. 1, Kehui Development Center, Science Ave., Guangzhou Science City, Huangpu District, Guangzhou, P. R. China
Tel: 86-20-38601850 Fax: 86-20-38601272 E-mail: info@mornsun.cn www.mornsun-power.com