

15W isolated DC-DC converter in DIP/SMD package
Ultra-wide input and regulated single output

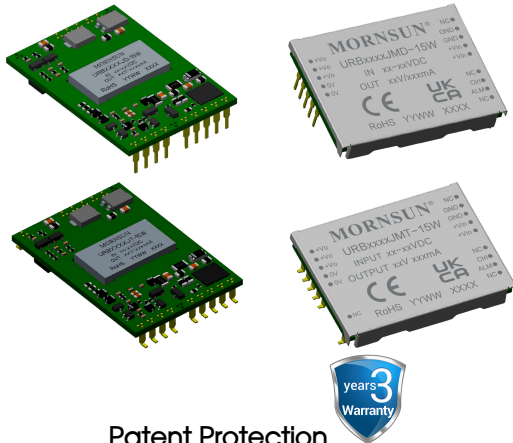

Patent Protection
CE Report EN62368-1
UK CA Report BS EN62368-1
RoHS

FEATURES

- Ultra-wide 4:1 input voltage range
- Ultra-thin DIP/SMD Package
- High efficiency up to 89%
- No-load power consumption as low as 0.36W
- I/O isolation test voltage 1.5kVDC
- Operating ambient temperature range
-40°C to +85°C
- Input under-voltage protection, output short-circuit, over-current, over-voltage protection

URB_J(M)D/T-15W series of isolated 15W DC-DC converter products with an ultra-wide 4:1 input voltage range. They feature efficiencies up to 89%, 1500VDC I/O isolation, input under-voltage protection, output short-circuit, over-current and over-voltage protection. They are ideally and widely used in applications such as industrial control, electric power, instruments and communications.

Selection Guide

Certification	Part No. ①	Input Voltage (VDC)		Output		Full Load Efficiency® (%)Min./Typ.	Capacitive Load (μF)Max.
		Nominal (Range)	Max. ②	Voltage(VDC)	Current (mA) Max./Min.		
EN/BS EN	URB2403J(M)D/T-15W	24 (9-36)	40	3.3	4500/0	86/88	4700
	URB2405J(M)D/T-15W			5	3000/0	86/88	4700
	URB2412J(M)D/T-15W			12	1250/0	87/89	1000
	URB2415J(M)D/T-15W			15	1000/0	87/89	820
	URB4803JMD/T-15W	48 (18-75)	80	3.3	4500/0	86/88	4700
	URB4805J(M)D/T-15W			5	3000/0	86/88	4700
	URB4812J(M)D/T-15W			12	1250/0	87/89	1000
	URB4815JD-15W			15	1000/0	87/89	820
URB4815JMD/T-15W			15	1000/0	87/89	820	

Note:

- ① URBxxxJ(M)D/T-15W contains 4 types of products, include URBxxxJD-15W(DIP package without case), URBxxxJMD-15W(DIP package with case), URBxxxJT-15W(SMD package without case) and URBxxxJMT-15W(SMD package with case);
- ② Exceeding the maximum input voltage may cause permanent damage;
- ③ Efficiency is measured in nominal input voltage and rated output load.

Input Specifications

Item	Operating Conditions			Min.	Typ.	Max.	Unit
Input Current (full load / no-load)	Nominal input voltage	24V input	3.3V, 5V output	--	710/40	727/60	mA
			12V, 15V output	--	702/15	718/30	
		48V input	3.3V, 5V output	--	355/30	363/45	
			12V, 15V output	--	351/10	360/25	
Reflected Ripple Current	Nominal input voltage			--	30	--	
Surge Voltage (1sec. max.)	24V input			-0.7	--	50	VDC
	48V input			-0.7	--	100	
Start-up Voltage	24V input			--	--	9	
	48V input			--	--	18	
Input Under-voltage Protection	24V input			5.5	6.5	--	
	48V input			12	15.5	--	

Start-up Current	24V input	--	--	3000	mA
	48V input	--	--	1500	
Input Filter		Pi filter			
Hot Plug		Unavailable			
Ctrl*	Module on	Ctrl pin open, Ctrl pin pulled low to GND or pulled low (0-1.2VDC)			
	Module off	Ctrl pin pulled high (3.5-12VDC)			
	Input current when off	--	6	15	mA
Alarm	Valm(relative to GND), when under-voltage protection is going to happen and during the over-voltage protection working status.	--	0.2	1.2	VDC
	Valm(relative to GND), other working status	3.5	9	--	

Note: *The voltage of Ctrl pin is relative to input pin GND.

Output Specifications

Item	Operating Conditions	Min.	Typ.	Max.	Unit	
Output Voltage Accuracy	0% -100% load	--	±1	±2	%	
Linear Regulation	Input voltage variation from low to high at full load	--	±0.2	±0.5		
Load Regulation ^①	5% -100% load	--	±0.5	±1		
Transient Recovery Time		--	300	500	μs	
Transient Response Deviation	25% load step change, nominal input	3.3V, 5V output	--	±3	±8	%
		Other output	--	±3	±5	
Temperature Coefficient	Full load	--	--	±0.03	%/°C	
Ripple & Noise ^②	20MHz bandwidth, 5% -100% load	--	50	100	mVp-p	
Output Over-voltage Protection		110	--	160	%Vo	
Output Over-current Protection	Input voltage range	110	180	230	%Io	
Short-circuit Protection		Hiccup, continuous, self-recovery				

Note: ① Load regulation for 0% -100% load increases to ±3%;

② Under 0% -5% load conditions, ripple & noise does not exceed 5%Vo. The "parallel cable" method is used for ripple and noise test, please refer to DC-DC Converter Application Notes for specific information.

General Specification

Item	Operating Conditions	Min.	Typ.	Max.	Unit
Isolation	Input-output Electric Strength Test for 1 minute with a leakage current of 1mA max.	1500	--	--	VDC
	Input-case Electric Strength Test for 1 minute with a leakage current of 1mA max. (Only for URB_JMD/JMT-15W series products)	500	--	--	
	Output-case Electric Strength Test for 1 minute with a leakage current of 1mA max.(Only for URB_JMD/JMT-15W series products)	500	--	--	
Insulation Resistance	Input-output Resistance at 500VDC, Ta=25°C, humidity=70%RH	100	--	--	MΩ
	Input-case Resistance at 500VDC, Ta=25°C, humidity=70%RH (Only for URB_JMD/JMT-15W series products)	100	--	--	
	Output-case Resistance at 500VDC, Ta=25°C, humidity=70%RH (Only for URB_JMD/JMT-15W series products)	100	--	--	
Isolation Capacitance	Input-output capacitance at 100kHz/0.1V	--	1000	--	pF
Operating Temperature	See Fig. 1	-40	--	+85	°C
Storage Temperature		-55	--	+125	
Storage Humidity	Non-condensing	5	--	95	%RH
Pin Soldering Resistance Temperature*	Soldering spot is 1.5mm away from case for 10 seconds	--	--	300	°C
	Wave soldering, 10 seconds	255	260	265	
Reflow soldering Temperature	Only for URB_J(M)T-15W series products	Peak temp. ≤245°C, maximum duration time ≤60s over 217°C. For actual application, please refer to IPC/JEDEC J-STD-020D.1.			

Vibration		10-150Hz, 5G, 60Min. along X, Y and Z			
Switching Frequency ^①	PWM mode	--	300	--	kHz
MTBF	MIL-HDBK-217F@25°C	1000	--	--	k hours
Moisture Sensitivity Level (MSL)	IPC/JEDEC J-STD-020D.1	Level 1			

Note:*The pin resistance temperature is not the actual set temperature of the soldering iron, but the temperature required for a good solder joint. The actual set temperature by the customer needs to be comprehensively set based on the thickness of the PCB, the size of the copper cladding, the power of the soldering iron, and the selection of the soldering iron tip.

①Switching frequency is measured at full load. The module reduces the switching frequency for light load (below 50%) efficiency improvement.

Mechanical Specifications

Case Material	Aluminum alloy	
Dimension	URB_JD-15W series	38.70 x 27.20 x 6.20 mm (3.3V/5V output), 38.70 x 27.20 x 5.80 mm (other output)
	URB_JT-15W series	39.90 x 27.20 x 6.20 mm (3.3V/5V output), 39.90 x 27.20 x 5.80 mm (other output)
	URB_JMD-15W series	39.10 x 29.50 x 6.80 mm (3.3V/5V output), 39.10 x 29.50 x 6.40 mm (other output)
	URB_JMT-15W series	39.90 x 29.50 x 6.80 mm (3.3V/5V output), 39.90 x 29.50 x 6.40 mm (other output)
Weight	URBxx03/05JD/T-15W series	11.0g (Typ.)
	URBxx12/15JD/T-15W series	8.8g (Typ.)
	URBxx03/05JMD/T-15W series	13.8g (Typ.)
	URBxx12/15JMD/T-15W series	11.5g (Typ.)
Cooling method	Free air convection (20LFM) or forced convection	

Electromagnetic Compatibility (EMC)

Emissions	CE	CISPR32/EN55032	CLASS B (see Fig.3-① for recommended circuit)	
	RE	CISPR32/EN55032	CLASS B (see Fig.3-① for recommended circuit)	
Immunity	ESD	IEC/EN61000-4-2	Contact ±6kV	perf. Criteria B
	RS	IEC/EN61000-4-3	10V/m	perf. Criteria A
	EFT	IEC/EN61000-4-4	±2kV (see Fig.3-② for recommended circuit)	perf. Criteria B
	Surge	IEC/EN61000-4-5	line to line ±2kV (see Fig.3-② for recommended circuit)	perf. Criteria B
	CS	IEC/EN61000-4-6	3 Vr.m.s	perf. Criteria A

Typical Characteristic Curve

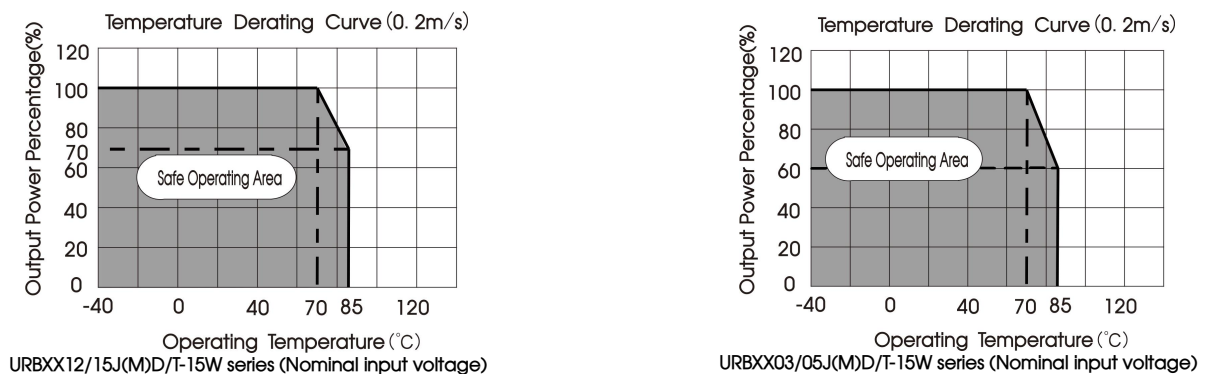
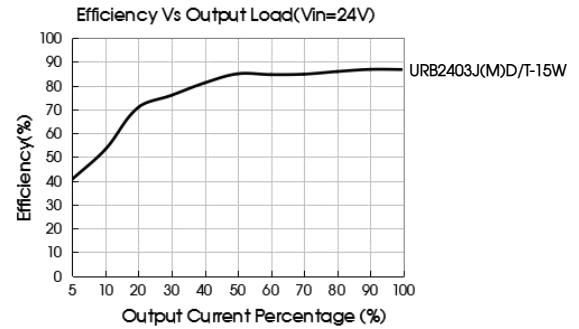
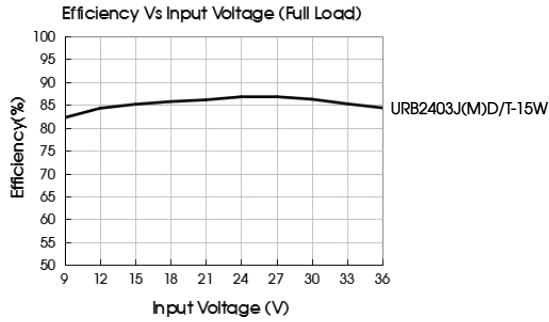
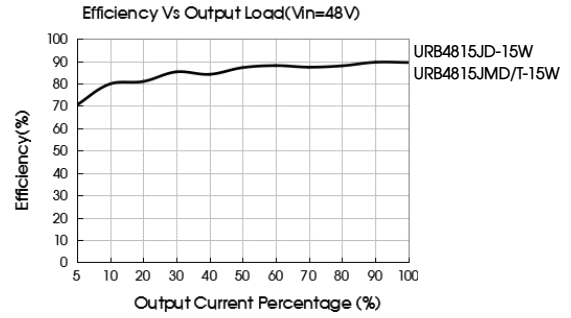
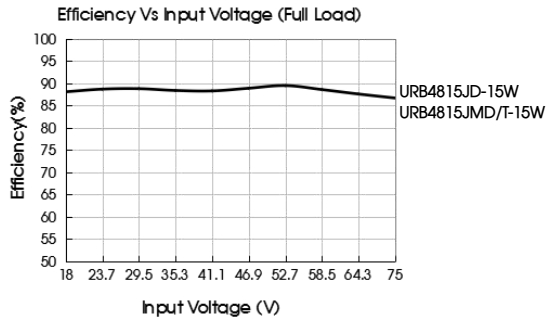

Fig. 1



Design Reference

1. Typical application

All the DC/DC converters of this series are tested according to the recommended circuit (see Fig. 2) before delivery. If it is required to further reduce input and output ripple, properly increase the input & output of additional capacitors C_{in} and C_{out} or select capacitors of low equivalent impedance provided that the capacitance is no larger than the max. capacitive load of the product.

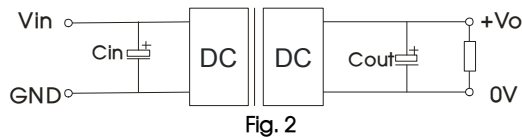

Vin (VDC)	Vout (VDC)	Cin	Cout
24	3.3/5	100μF/50V	10μF/16V
	12/15		10μF/25V
48	3.3/5	100μF/100V	10μF/16V
	12/15		10μF/25V

2. EMC compliance recommended circuit

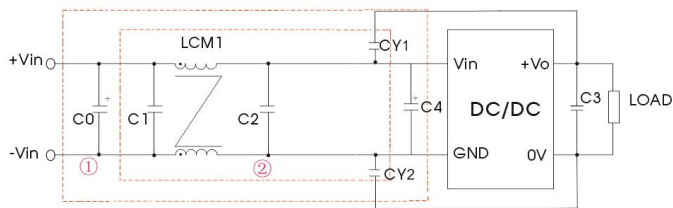

Fig. 3

Note: Part ① in the Fig. 3 is used for immunity test and part ② for emissions filtering. Selecting based on needs.

Parameter description:

Model	Vin: 24VDC	Vin: 48VDC
FUSE	Choose according to actual input current	
C0	470μF/50V	680μF/100V
C1/C2	4.7μF/50V	4.7μF/100V
C4	330μF/50V	330μF/100V
C3	Refer to the Cout in Fig.2	
LCM1	FL2D-30-472	
CY1/CY2	2000pF/2kV	

Note: *For URBxxxJMD/T-15W, the case should be connected to input pin GND when testing EMC performance.

3. For additional information please refer to DC-DC converter application notes on www.mornsun-power.com

URB_JD-15W (DIP package without case) Dimensions and Recommended Layout

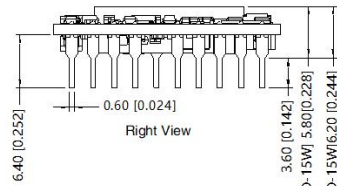
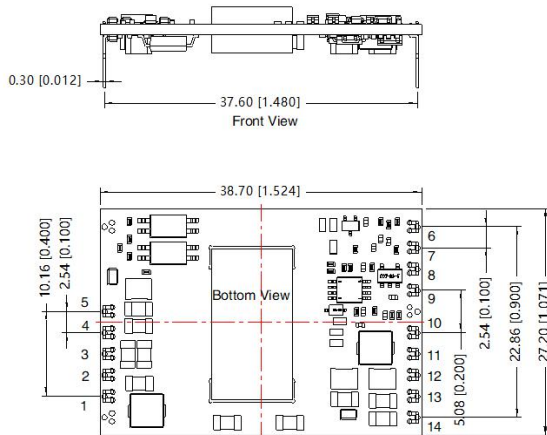

Pin-Out			
Pin	Mark	Pin	Mark
1	+Vo	8	Ctrl
2	+Vo	9	NC
3	+Vo	10	+Vin
4	0V	11	+Vin
5	0V	12	GND
6	NC	13	GND
7	ALM	14	NC

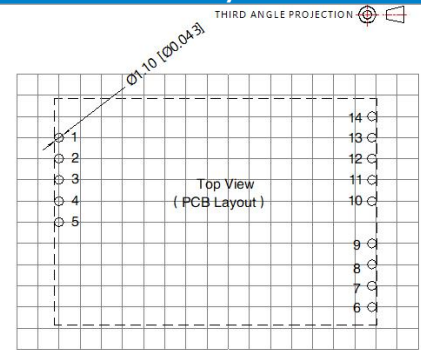

Note: Grid 2.54*2.54mm

Note:
Unit: mm[inch]
Pin section tolerances: $\pm 0.10[\pm 0.004]$
General tolerances: $\pm 0.50[\pm 0.020]$
The layout of the device is for reference only, please refer to the actual product

URB_JMD-15W (DIP package with case) Dimensions and Recommended Layout

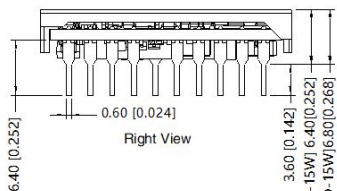
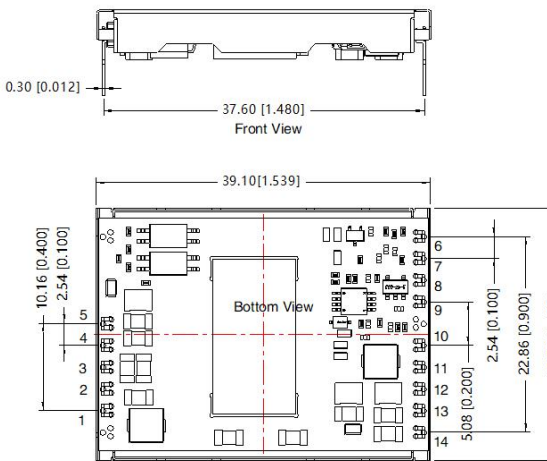

Pin-Out			
Pin	Mark	Pin	Mark
1	+Vo	8	Ctrl
2	+Vo	9	NC
3	+Vo	10	+Vin
4	0V	11	+Vin
5	0V	12	GND
6	NC	13	GND
7	ALM	14	NC

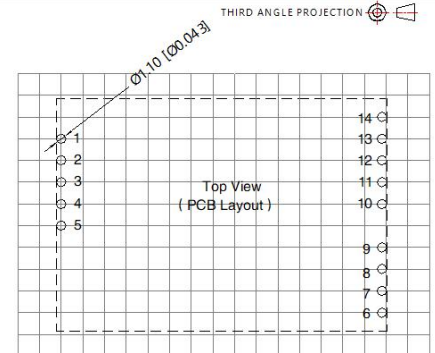

Note: Grid 2.54*2.54mm

Note:
Unit: mm[inch]
Pin section tolerances: $\pm 0.10[\pm 0.004]$
General tolerances: $\pm 0.50[\pm 0.020]$
The layout of the device is for reference only, please refer to the actual product

URB_JT-15W (SMD package without case) Dimensions and Recommended Layout

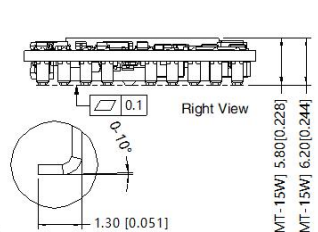
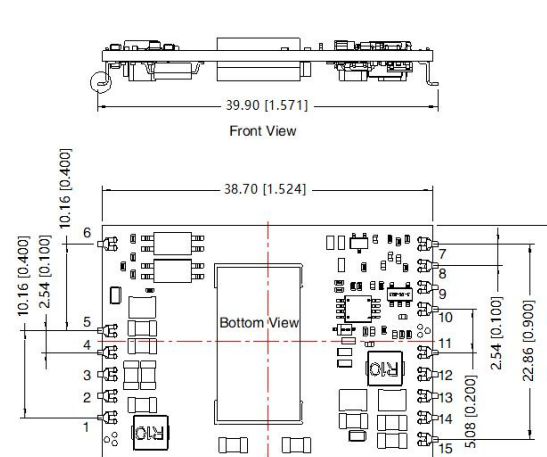

Pin-Out			
Pin	Mark	Pin	Mark
1	+Vo	9	Ctrl
2	+Vo	10	NC
3	+Vo	11	+Vin
4	0V	12	+Vin
5	0V	13	GND
6	NC	14	GND
7	NC	15	NC
8	ALM		

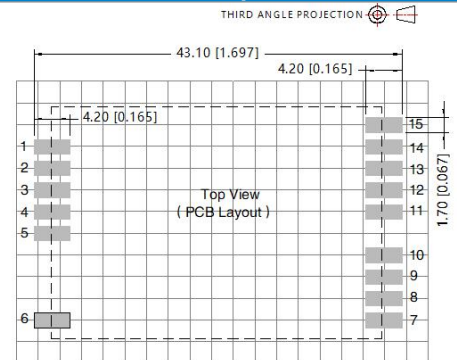

Note: Grid 2.54*2.54mm

Note:
Unit: mm[inch]
Pin section tolerances: $\pm 0.10[\pm 0.004]$
General tolerances: $\pm 0.50[\pm 0.020]$
The layout of the device is for reference only, please refer to the actual product

URB_JMT-15W (SMD package with case) Dimensions and Recommended Layout

THIRD ANGLE PROJECTION

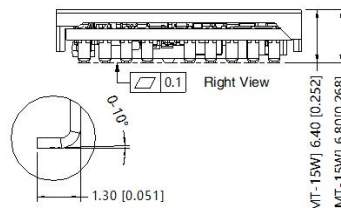
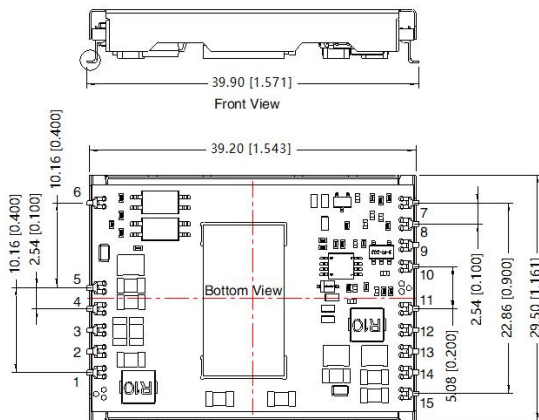

Pin-Out			
Pin	Mark	Pin	Mark
1	+Vo	9	Ctrl
2	+Vo	10	NC
3	+Vo	11	+Vin
4	0V	12	+Vin
5	0V	13	GND
6	NC	14	GND
7	NC	15	NC
8	ALM		

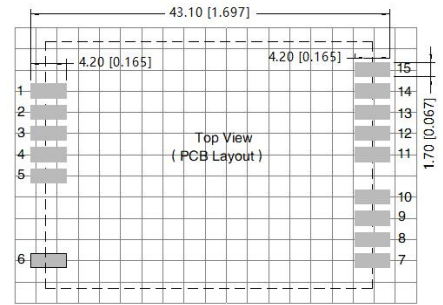

Note: Grid 2.54*2.54mm

Note:
Unit: mm[inch]
Pin section tolerances: $\pm 0.10 [\pm 0.004]$
General tolerances: $\pm 0.50 [\pm 0.020]$
The layout of the device is for reference only, please refer to the actual product

Note:

- For additional information on Product Packaging please refer to www.mornsun-power.com. Packaging bag number 58210126;
- If the product is not operated within the required load range, the product performance cannot be guaranteed to comply with all parameters in the datasheet;
- The maximum capacitive load offered were tested at input voltage range and full load;
- Unless otherwise specified, parameters in this datasheet were measured under the conditions of $T_a=25^\circ\text{C}$, humidity<75%RH with nominal input voltage and rated output load;
- All index testing methods in this datasheet are based on company corporate standards;
- We can provide product customization service, please contact our technicians directly for specific information;
- Products are related to laws and regulations: see "Features" and "EMC";
- Our products shall be classified according to ISO14001 and related environmental laws and regulations, and shall be handled by qualified units.

Mornsun Guangzhou Science & Technology Co., Ltd.

Address: No. 8, Nanyun 4th Road, Huangpu District, Guangzhou, China
Tel: 86-20-38601850

Fax: 86-20-38601272

E-mail: info@mornsun.cn

www.mornsun-power.com