

40W isolated DC-DC converter in DIP package
Ultra-wide input and regulated single output

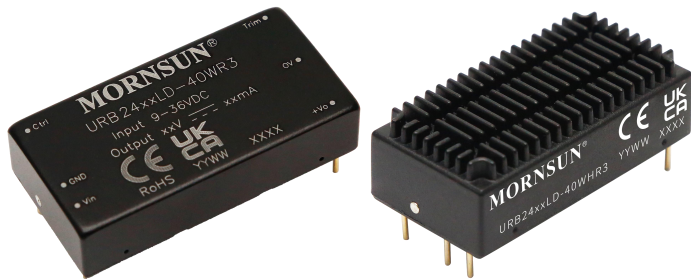

EN62368-1 BS EN62368-1

Patent Protection RoHS



FEATURES

- Ultra-wide 4:1 input voltage range
- High efficiency up to 93%
- I/O isolation test voltage 1.5K VDC
- Input under-voltage protection, output short-circuit, over-current, over-voltage protection
- Operating ambient temperature range: -40°C to +105°C
- Six-sided metal shielding package
- Industry standard pin-out

URB24_LD-40W(H)R3 series of isolated 40W DC-DC converter products with an ultra-wide 4:1 input voltage range. They feature efficiencies up to 93%, input to output isolation is tested with 1500VDC and the converter safety operate ambient temperature of -40°C to +105°C, input under-voltage protection, output over-voltage, over-current, short-circuit protection. They are ideally and widely used in applications such as industrial control, electric power, instruments and communications fields.

Selection Guide

Certification	Part No.	Input Voltage (VDC)		Output		Full Load Efficiency ^② (%) Min./Typ.	Capacitive Load (μF)Max.
		Nominal (Range)	Max. ^①	Voltage (VDC)	Current(mA) Max./Min.		
EN/BS EN	URB2405LD-40W(H)R3	24(9-36)	40	05	8000/400	89/91	15000
	URB2412LD-40W(H)R3			12	3333/166	90/92	3000
	URB2415LD-40W(H)R3			15	2666/133	91/93	2200
	URB2424LD-40W(H)R3			24	1666/83	90/92	1300

Notes:

- ①Exceeding the maximum input voltage may cause permanent damage;
②Efficiency is measured at nominal input voltage and rated output load.

Input Specifications

Item	Operating Conditions	Min.	Typ.	Max.	Unit	
Input Current (full load / no-load)	Nominal input voltage	5V output	--	1831/15	1872/30	mA
		12V/24V output	--	1811/15	1851/30	
		15V output	--	1972/15	1831/30	
Reflected Ripple Current	Nominal input voltage, 100% load	--	--	40	VDC	
Surge Voltage (1sec. max.)		-0.7	--	50		
Start-up Voltage		--	--	9		
Input Filter		PI filter				
Hot Plug		Unavailable				
Ctrl*	Module on	Ctrl pin open or pulled high TTL (3-12VDC)				
	Module off	Ctrl pin pulled low to GND (0-1.2VDC)				
	Input current when off	--	6	12		

Note: *The Ctrl pin voltage is referenced to input GND.

Output Specifications

Item	Operating Conditions	Min.	Typ.	Max.	Unit
Voltage Accuracy	5%-100% load	--	±1	±2	%
	0%-5% load	--	±2	±5	
Linear Regulation	Input voltage variation from low to high at full load	--	±0.2	±0.5	

Load Regulation	5%-100% load		--	±0.5	±1	%
Transient Response Deviation	25% load step change, input voltage range	5V output	--	±3	±10	
Transient Response Deviation		Other output	--	±3	±5	
Transient Recovery Time	25% load step change, nominal input voltage		--	250	500	μs
Temperature Coefficient	Full load		--	--	±0.03	%/°C
Ripple & Noise ^①	20MHz bandwidth, 5%-100% load		--	100	200	mV p-p
	20MHz bandwidth,	5V output	--	--	5	%Vo
		Other output	--	--	3	
Over-voltage Protection	Input voltage range		110	140	160	%Vo
Over-current Protection			110	140	200	%Io
Short-circuit Protection			Continuous, self-recovery			
Note: ①By measuring method is used for Ripple and Noise test, please refer to Fig. 2. for recommended circuit.						

General Specifications

Item	Operating Conditions	Min.	Typ.	Max.	Unit
Isolation	Input-output Electric Strength Test for 1 minute with a leakage current of 1mA max.	1500	--	--	VDC
	Input/output-Case Electric Strength Test for 1 minute with a leakage current of 1mA max.	1000	--	--	
Insulation Resistance	Input-output resistance at 500VDC	100	--	--	MΩ
Isolation Capacitance	Input-output capacitance at 100KHz/0.1V	--	1400	--	pF
Operating Temperature	See Fig. 1	-40	--	+105	°C
Storage Temperature		-55	--	+125	
Storage Humidity	Non-condensing	5	--	95	%RH
Pin Soldering Resistance Temperature	Soldering spot is 1.5mm away from case for 10 seconds	--	--	+300	°C
Vibration		10-150Hz, 5G, 0.75mm. along X, Y and Z			
Switching Frequency ^①	PWM mode	--	370	--	KHz
MTBF	MIL-HDBK-217F@25°C	1000	--	--	K hours
Note: ①Switching frequency is measured at full load. The module reduces the switching frequency for light load (below 50%) efficiency improvement.					

Mechanical Specifications

Case Material	Aluminum alloy				
Dimensions	Without heat sink	50.80 x 25.40 x 11.80 mm			
	Heat sink	51.40 x 26.20 x 16.50 mm			
Weight	Without heat sink	41.0g(Typ.)			
	Heat sink	50.8g(Typ.)			
Cooling Method	Free air convection				

Electromagnetic Compatibility (EMC)

Emissions	CE	CISPR32/EN55032	CLASS A (Vout=12/15V see Fig. 3-① for recommended circuit, Vout=05/24V see Fig. 3-③ for recommended circuit) CLASS B (Vout=12/15V see Fig. 3-② for recommended circuit, Vout=05/24V see Fig. 3-④ for recommended circuit)
	RE	CISPR32/EN55032	CLASS A (Vout=12/15V see Fig. 3-① for recommended circuit, Vout=05/24V see Fig. 3-③ for recommended circuit) CLASS B (Vout=12/15V see Fig. 3-② for recommended circuit, Vout=05/24V see Fig. 3-④ for recommended circuit)

Immunity	ESD	IEC/EN61000-4-2	Contact $\pm 6\text{KV}$	perf. Criteria B
	RS	IEC/EN61000-4-3	10V/m	perf. Criteria A
	EFT	IEC/EN61000-4-4	100KHz $\pm 2\text{KV}$ (Vout=12/15V see Fig. 3-② for recommended circuit, Vout=05/24V see Fig. 3-④ for recommended circuit)	perf. Criteria A
	Surge	IEC/EN61000-4-5	line to line $\pm 2\text{KV}$ (Vout=12/15V see Fig. 3-② for recommended circuit, Vout=05/24V see Fig. 3-④ for recommended circuit)	perf. Criteria A
	CS	IEC/EN61000-4-6	10 Vr.m.s	perf. Criteria A

Typical Characteristic Curves

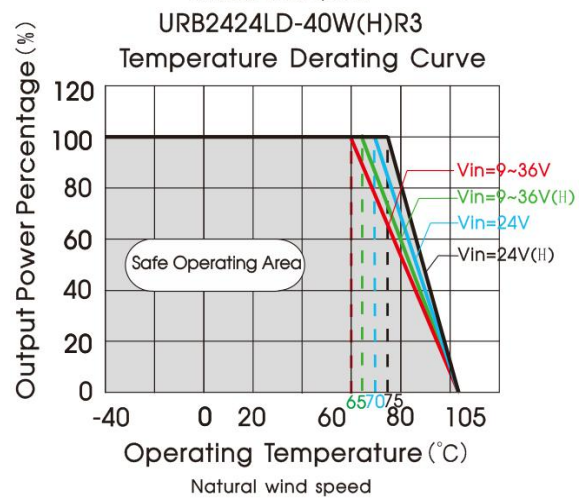
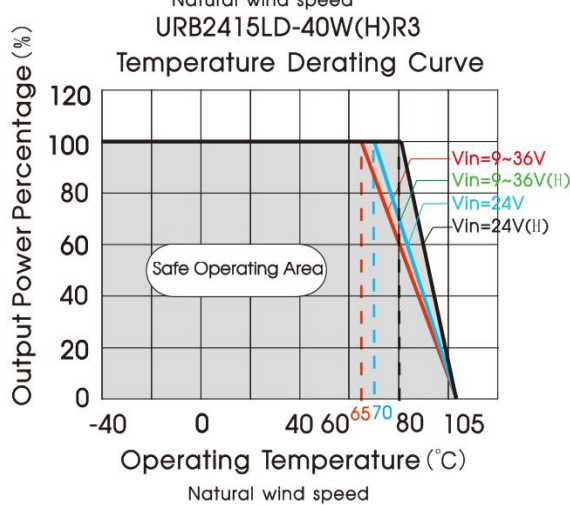
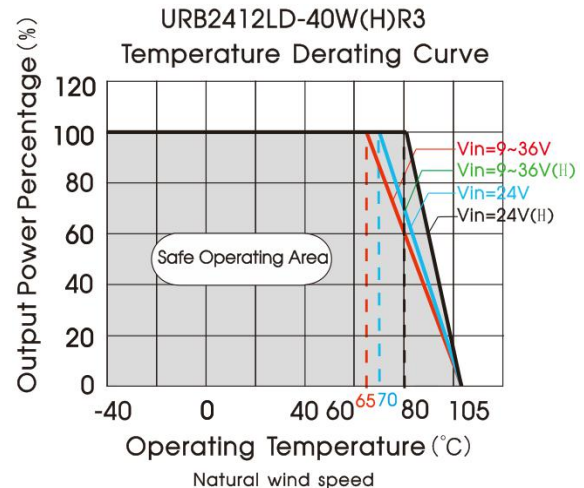
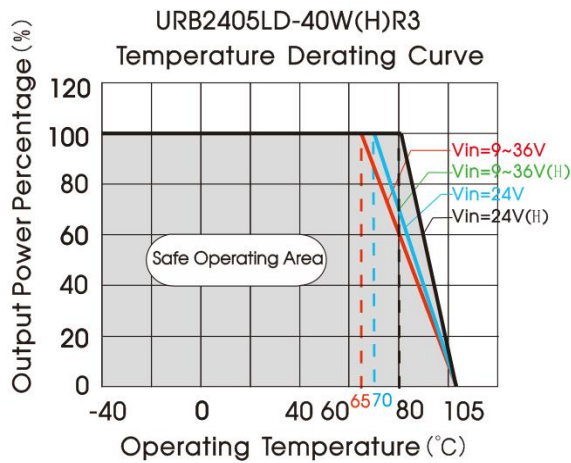

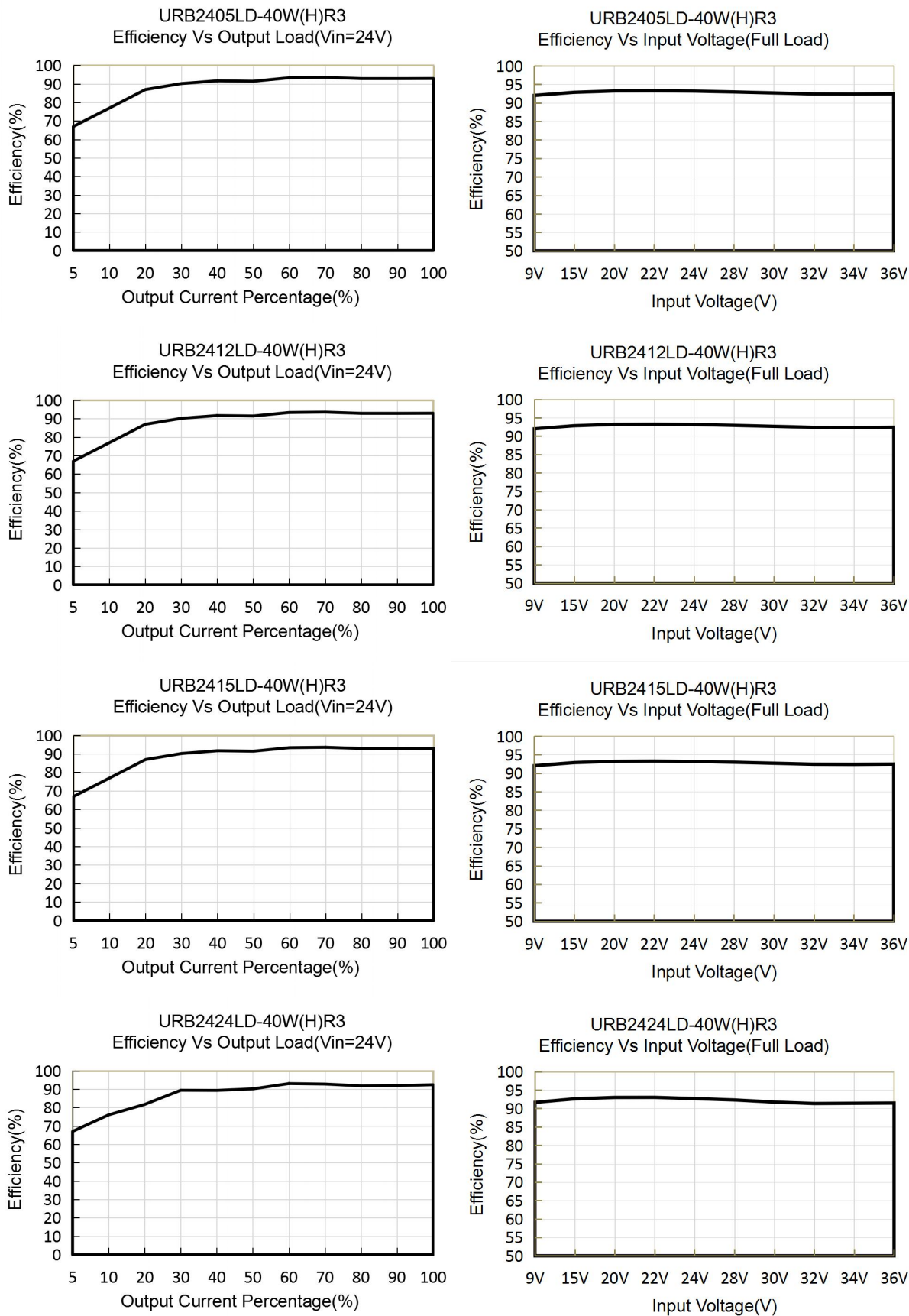

Fig. 1

Design Reference

1. Typical application

All the DC-DC converters of this series are tested before delivery using the recommended circuit shown in Fig. 2.

Input and/or output ripple can be further reduced by appropriately increasing the input & output capacitor values C_{in} and C_{out} and/or by selecting capacitors with a low ESR (equivalent series resistance). Also make sure that the capacitance is not exceeding the specified max. capacitive load value of the product.



Fig. 2

Vout (VDC)	Cin (μF)	Cout (μF)
5	100μF/50V	220μF/16V
12/15		100μF/50V
24		47μF/50V

2. EMC compliance circuit

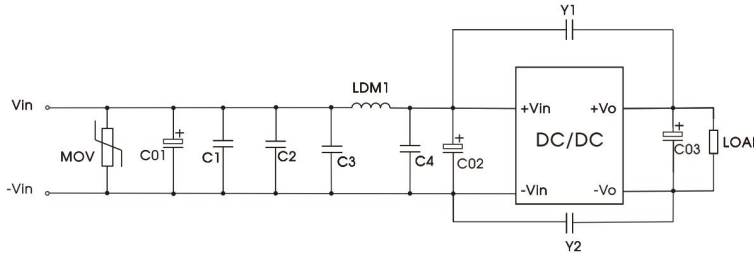

Fig. 3-①

Table 1: recommended component parameters

Model	Parameter	Parameter description
C1/C2	4.7uF	50V
C3/C4	10uF	50V
C01	680uF	50V
C02	330uF	50V
C03	100uF	50V
Y1/Y2	2.2nF	Y1
LDM1	2.2uH	/
MOV	S14K30	/

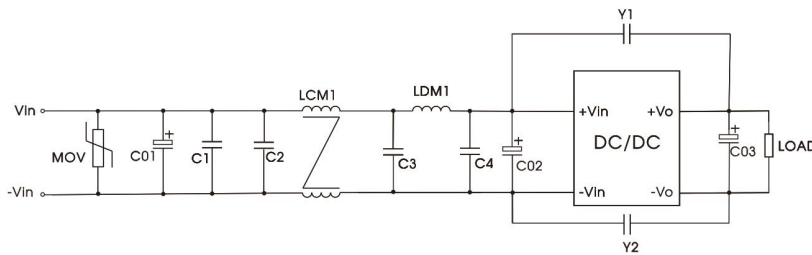

Fig. 3-②

Table 2: recommended component parameters

Model	Parameter	Parameter description
C1/C2	4.7uF	50V
C3/C4	10uF	50V
C01	680uF	50V
C02	330uF	50V
C03	100uF	50V
Y1/Y2	2.2nF	Y1
LCM1	2.2mH	recommended to use MORNSUN P/N: FL2D-30-222
LDM1	2.2uH	/
MOV	S14K30	/

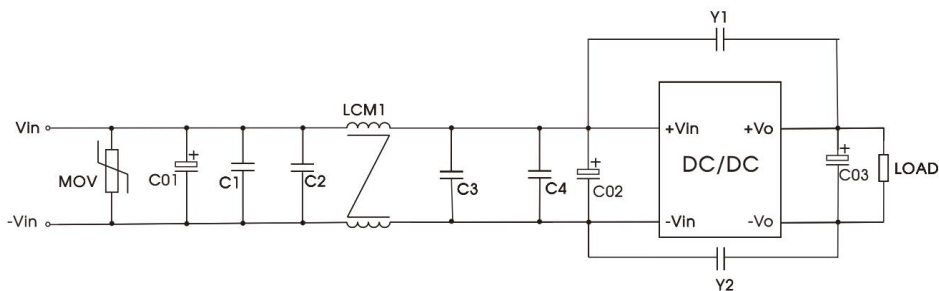

Fig. 3-③

Table 3: recommended component parameters

Model	Parameter	Parameter description
C1/C2	4.7uF	50V
C3/C4	10uF	50V
C01	680uF	50V
C02	330uF	50V
C03	100uF	50V
Y1/Y2	2.2nF	Y1
LCM1	10mH	10.0mH MIN/180mΩ Max
MOV	S14K30	/

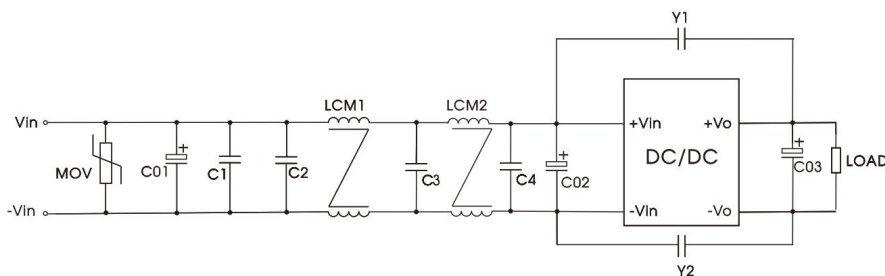
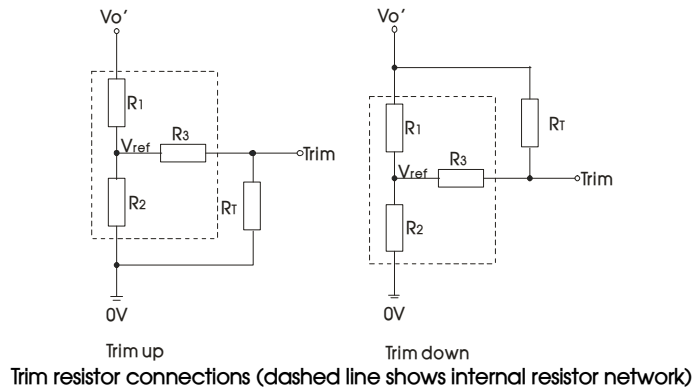

Fig. 3-④

Table 4: recommended component parameters

Model	Parameter	Parameter description
C1/C2	4.7uF	50V
C3	10uF	50V
C4	47uF	50V
C01	680uF	50V
C02	330uF	50V
C03	100uF	50V
Y1/Y2	2.2nF	Y1
LCM1/LCM2	10mH	10.0mH MIN/180mΩ Max
MOV	S14K30	/

3. Trim Function for Output Voltage Adjustment (open if unused)



Calculating Trim resistor values:

$$\begin{aligned} \text{up: } R_T &= \frac{\alpha R_2}{R_2 - \alpha} - R_3 & \alpha &= \frac{V_{ref}}{V_{o'} - V_{ref}} \cdot R_1 & R_T &= \text{Trim Resistor value} \\ \text{down: } R_T &= \frac{\alpha R_1}{R_1 - \alpha} - R_3 & \alpha &= \frac{V_{o'} - V_{ref}}{V_{ref}} \cdot R_2 & \alpha &= \text{self-defined parameter} \\ & & & & V_{o'} &= \text{desired output voltage} \end{aligned}$$

Vout(VDC)	R1(KΩ)	R2(KΩ)	R3(KΩ)	Vref(V)
05	2.97	2.87	6.1	2.5
12	10.91	2.87	6.1	2.5
15	14.35	2.87	6.1	2.5
24	24.77	2.87	6.1	2.5

4. Recommended solution for thermal testing

During the application process, the thermal design of the product can be evaluated in combination with the temperature derating curve of the product, or it can be determined by testing the temperature at point A, it is an safe operating area if the temperature lower than 100°C.



5. Reflected ripple current test circuit

All DC-DC converters of this series are tested using the recommended circuit shown in Fig. 5. Test point.

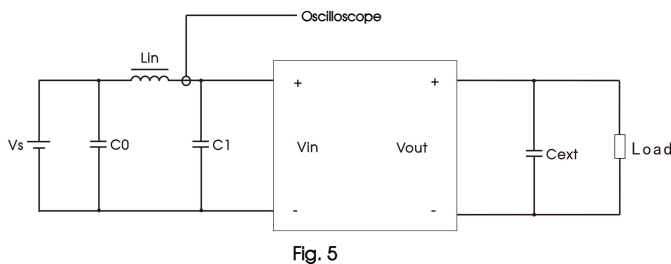

Components	Recommended Component Value
C0	220μF/100V
Lin	10uH/15A
C1	470μF/100V
Cext	470μF/63V

6. The products do not support parallel connection of their output

7. For additional information please refer to DC-DC converter application notes on

www.mornsun-power.com

URB24_LD-40WR3 Dimensions and Recommended Layout

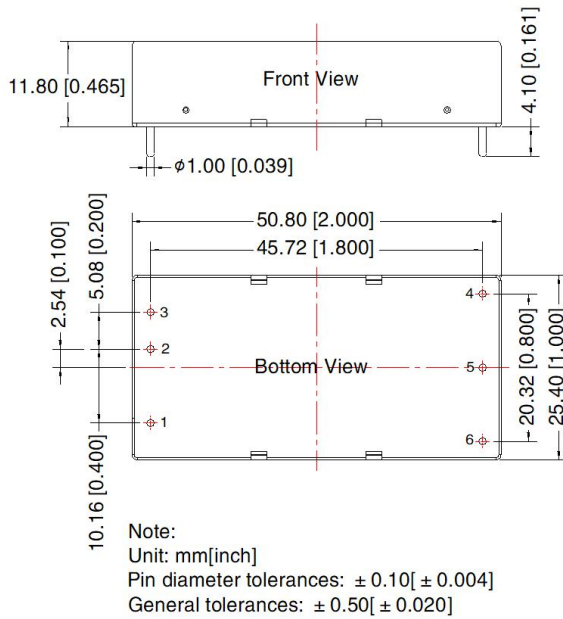

THIRD ANGLE PROJECTION

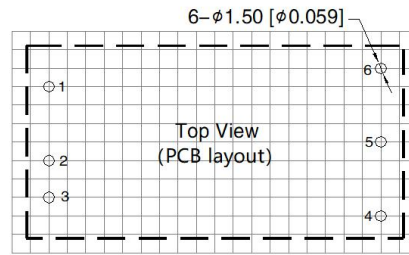

Pin-Out	
Pin	Mark
1	Ctrl
2	GND
3	Vin
4	+Vo
5	0V
6	Trim

URB24_LD-40WHR3 Dimensions and Recommended Layout

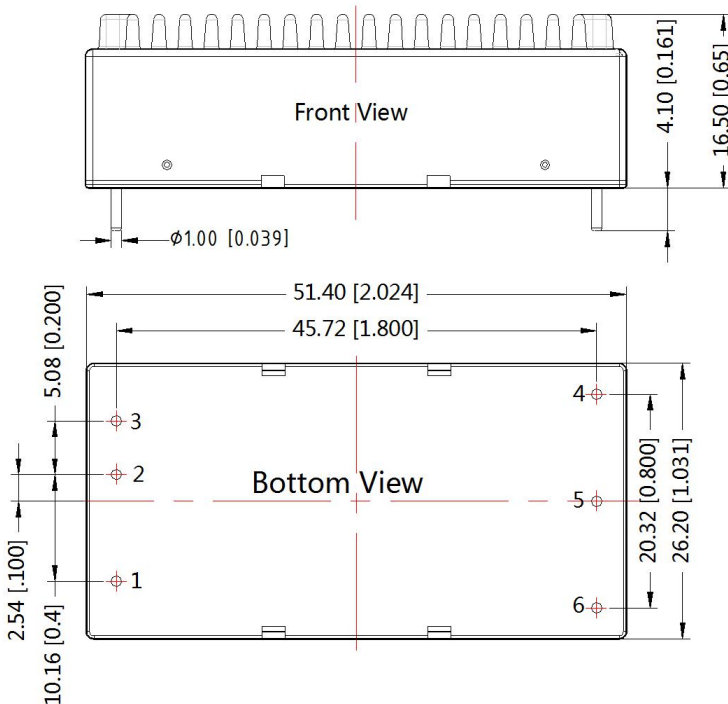

THIRD ANGLE PROJECTION

Pin-Out	
Pin	Function
1	Ctrl
2	GND
3	Vin
4	+Vo
5	0V
6	Trim

Note:
Unit: mm[inch]
General tolerances: ± 0.50 [± 0.020]

Note:

1. For additional information on Product Packaging please refer to www.mornsun-power.com. Packaging number: 58200035(without heat sink), 58200051(with heat sink);
2. Recommended used in more than 10% load, if the load is lower than 10%, then the ripple index of the product may exceed the specification, but does not affect the reliability of the product;
3. If the product is not operated within the required load range, the product performance cannot be guaranteed to comply with all parameters in the datasheet;
4. The maximum capacitive load offered were tested at input voltage range and full load;
5. Unless otherwise specified, parameters in this datasheet were measured under the conditions of $T_a=25^{\circ}\text{C}$, humidity<75%RH with nominal input voltage and rated output load;
6. All index testing methods in this datasheet are based on company corporate standards;
7. We can provide product customization service, please contact our technicians directly for specific information;
8. Products are related to laws and regulations: see "Features" and "EMC";
9. Our products shall be classified according to ISO14001 and related environmental laws and regulations, and shall be handled by qualified units.

Mornsun Guangzhou Science & Technology Co., Ltd.

Address: No. 5, Kehui St. 1, Kehui Development Center, Science Ave., Guangzhou Science City, Huangpu District, Guangzhou, P. R. China
Tel: 86-20-38601850 Fax: 86-20-38601272 E-mail: info@mornsun.cn www.mornsun-power.com