

RTD detection type isolated module

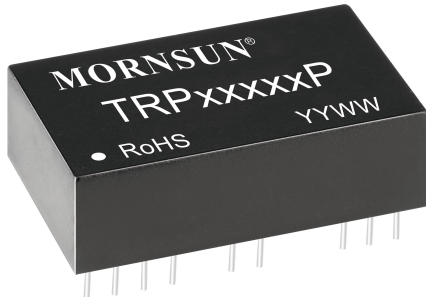

RoHS

FEATURES

- Two-wire, three-wire or four-wire Pt100 RTD signal input
- High accuracy of 0.2% FS
- High linearity of 0.2% FS
- Isolation test voltage 2.0kVAC for 60s
- Low ripple & noise: $\leq 30\text{mVp-p}$
- Extremely low temperature coefficient of 50PPM/ $^{\circ}\text{C}$ typical, over entire range from -40°C to $+85^{\circ}\text{C}$
- Operating temperature range: -40°C to $+85^{\circ}\text{C}$
- High reliability, Low cost compact design, Convenient to use
- Standard DIP24 Package (31.6 x 20.3 x 10.2mm), UL94-V0

TRP series is a hybrid integrated temperature signal isolation module. It converts the RTD (resistance temperature detector) temperature sensor signal into an isolated standard linear current or voltage signal that is proportional to the temperature. The circuit on the same chip integrates a set of multi-channel high isolated DC/DC power supply, several high-performance signal isolators, and RTD linearization, long-term compensation, interference suppression circuit. Especially suitable for Pt100 RTD signal isolation converted into a standard signal isolation, temperature signals transmission and remote without distortion, temperature signal acquisition and isolated of DCS system or industrial site PLC.

Chip integrates a high-efficiency DC-DC, it can produce two groups were separated from each other to the internal power amplifier inputs, modulation circuit supply and outputs of the demodulator circuit, switching circuit, and filter circuit. The SMD structure with new isolation technologies allow the device to reach high power to signal input and to signal output Three-terminal isolation of 2000VAC. The products are ideal for use in harsh operating environments where compliance to vibration, industrial grade temperature range and high humidity are required.

TRP series temperature signal isolation modules are very convenient to use, to achieve Pt100 RTD signal isolation transmitter with a minimum of external components.

Selection Guide

Certification	Part No.	Power Supply input (VDC)	Input Signal	Output Signal	Isolated Power Output (VDC)
EN	TRP16130P	24	Pt100 (0 $^{\circ}\text{C}$ to +200 $^{\circ}\text{C}$)	4-20mA	None
	TRP15130P	24	Pt100 (0 $^{\circ}\text{C}$ to +100 $^{\circ}\text{C}$)	4-20mA	None
	TRP18130P	24	Pt100 (-50 $^{\circ}\text{C}$ to +150 $^{\circ}\text{C}$)	4-20mA	None
	TRP15S30P-2.5	24	Pt100 (0 $^{\circ}\text{C}$ to +100 $^{\circ}\text{C}$)	0-2.5V	None
	TRP16150P	12	Pt100 (0 $^{\circ}\text{C}$ to +200 $^{\circ}\text{C}$)	4-20mA	None
	TRP17130P	24	Pt100 (0 $^{\circ}\text{C}$ to +500 $^{\circ}\text{C}$)	4-20mA	None
--	TRP17150P	12	Pt100 (0 $^{\circ}\text{C}$ to +500 $^{\circ}\text{C}$)	4-20mA	None

Input Specifications

Item	Operating Conditions	Value
Power Input	Input Voltage	24V $\pm 5\%$
		12V $\pm 5\%$
	Input Power	Signal full load $\leq 1\text{W}$
	Power Supply Protection	Input reverse polarity protection
Signal Input	Input Signal	Pt100
	Input Impedance	Reference selection guide

Output Specifications

Item	Operating Conditions	Value	
Output signal	Output Signal	Voltage output	0-2.5V
		Current output	4-20mA
	Load Capacity	Voltage output	$\geq 10\text{k}\Omega$
		Current output @ 20mA	$\leq 500\Omega$

	Load Regulation		0.050% FS
	Ripple & Noise	20MHz bandwidth	≤30mVpp

Transmission Specifications

Item	Operating Conditions		Value
Zero Offset			None
Precision	TRP17130P	External regulation resistor (20k)	±0.2% Full Scale, typical (0.5% FS, Max.)
	TRP17150P		
	Other models	External regulation resistor (10k)	
Temperature Coefficient	Operating temperature range: -40°C to +85°C		50PPM/°C, typical (100PPM/°C, Max.)
Adjustable Function	Full-scale regulation	TRP17130P	External regulation resistor (20k)
		TRP17150P	
		Other models	
	Zero regulation	TRP17130P	External regulation resistor (20k)
		TRP17150P	
		Other models	

General Specifications

Item	Operating Conditions		Value
Electric Isolation			Input to output and I/O to power supply isolation
Electric Strength Test	For 1 minute with a leakage current of <5mA, humidity <70%RH		2.0kVAC / 60S
Insulation Resistance	At 500VDC (signal input to signal output and I/O to power supply terminals)		100M Ω
Soldering Temperature	Wave-soldering		260±5°C; Soldering time: 5-10s
	Manual-soldering		360±10°C; Soldering time: 3-5s
Operating Ambient Temperature			-40°C to +85°C
Transportation and Storage Temperature			-50°C to +105°C
Maximum Case Temperature	Ta=25°C	≤50°C (Other models)	
		≤60°C (TRP17130P, TRP17150P)	
Safety Standard			EN62368-1 (Report)
Safety Class			CLASS III
Application Environment			The presence of dust, severe vibration, shock and corrosive gas may cause damage to the product

Physical Specifications

Case Material	Black plastic, flame-retardant and heat-resistant
Package	DIP24
Weight	11.3g (Typ.)
Cooling Method	Free air convection

Electromagnetic Compatibility(EMC)

Emissions	CE	CISPR32/EN55032	CLASS A (see Fig. 4 for recommended circuit)	
	RE	CISPR32/EN55032	CLASS A (see Fig. 4 for recommended circuit)	
Immunity	ESD	IEC/EN61000-4-2	Contact ±4kV	perf. Criteria B
	EFT	IEC/EN61000-4-4	Power supply port ±2kV (see Fig. 4 for recommended circuit)	perf. Criteria B
	Surge	IEC/EN61000-4-5	Power supply port ±1kV (line to line) (see Fig. 4 for recommended circuit)	perf. Criteria B

Application Precautions

1. Carefully read and follow the instructions before use; contact our technical support if you have any question.
2. Do not use the product in hazardous areas.
3. Use only DC power supply source for this product. 220V AC power supply is prohibited.
4. It is strictly forbidden to disassemble the product privately in order to avoid product failure or malfunction.

After-sales service

1. Factory inspection and quality control are strictly enforced before shipping any product; please contact your local representative or our technical support if you experience any abnormal operation or possible failure of the module.
2. The products have a 3-year warranty period, from the date of shipment. The product will be repaired or exchanged free of charge within the warranty period for any quality problem that occurs under normal use.

Applied circuit

See *Application Notes for Isolated Transmitter* for details.

Design Reference

1. Product block diagram

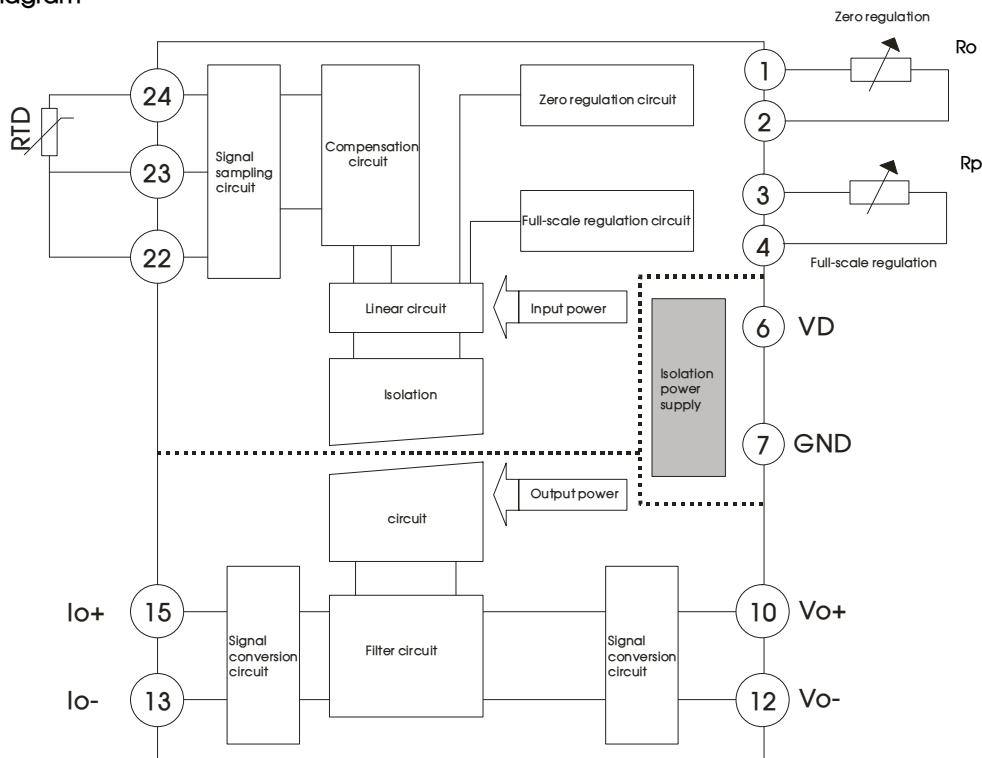

Fig. 1

2. Typical application

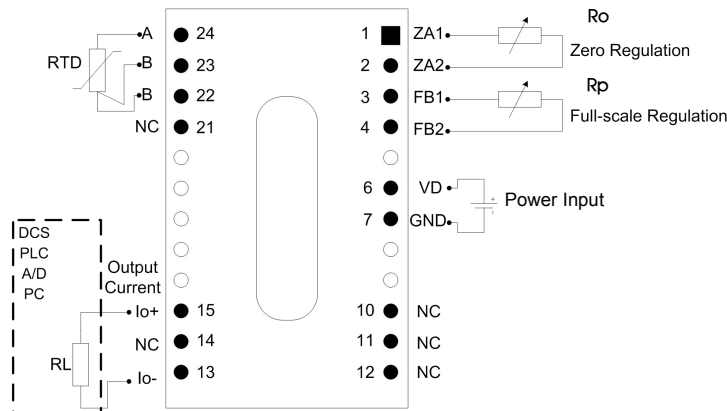

Fig. 2 Wiring diagram for products using Current output

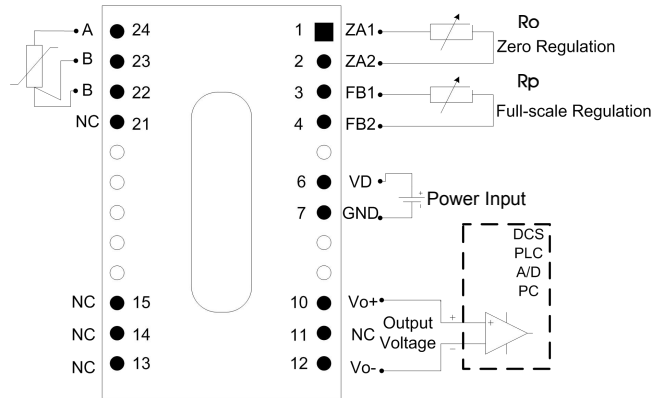

Fig. 3 Wiring diagram for product using Voltage output

- Notes: ①All NC Pins are to be isolated from circuit
②The selection of Ro and Rp are recommended as follows:

External regulation resistor Applicable model	Ro	Rp
TRP17130P, TRP17150P	20k Ω	20k Ω
Other models	10k Ω	10k Ω

3. Product calibration

Calibration Equipment: Resistance box (accuracy 0.01), DC power source, Multi-meter with Four and a half digits.

Calibration steps:

- 1) Refer to above wiring diagram or install the product into the actual application circuit.
- 2) Connect correct DC power source to input, install adjustment potentiometer and connect multimeter to the output of the product.
- 3) According to the temperature range of input to query the indexing table corresponding resistance value range (Rlow-Rhigh).
- 4) Turn on power for 15 minutes to let system stabilize (Recommended).
- 5) With resistance box setting equal to resistance Rlow value: Adjust Zero potentiometer to the output value corresponding to zero (eg. 4mA).
- 6) With resistance box setting equal to resistance Rhigh value; Adjust Amplitude potentiometer to the output value corresponding to Full-Degree (eg. 20mA).
- 7) In order to calibrate the output value exactly, steps 5 and 6 may have to be repeat several times before the calibration is completely finished.
- 8) Calibration finished.

4. EMC compliance circuit

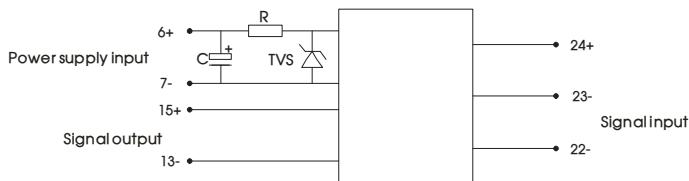

Fig. 4

Component	Recommended part, value
TVS	SMCJ30A
R	12 Ω 2W Wirewound
C	220uF/35V

5. For additional information please refer to application notes on www.mornsun-power.com

Dimensions and Recommended Layout

THIRD ANGLE PROJECTION 

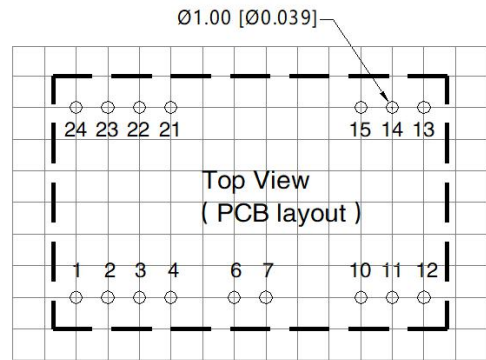
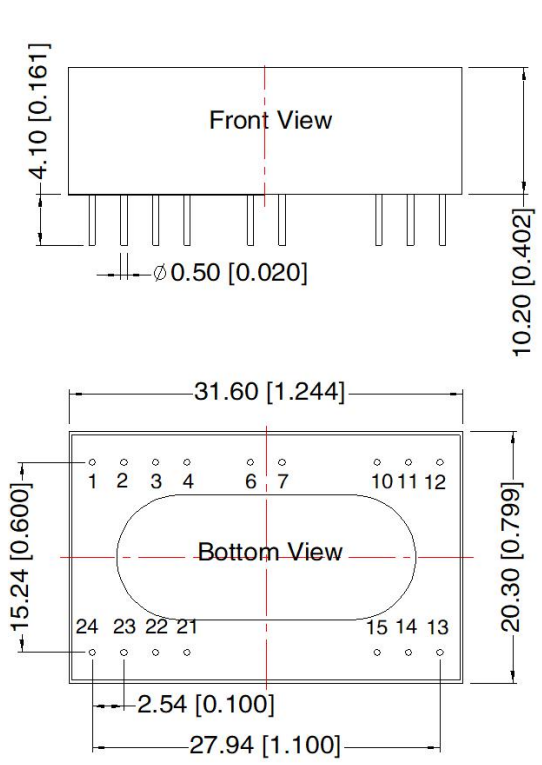

Note: Grid 2.54*2.54mm

Note:
Unit: mm[inch]
Pin diameter tolerances: $\pm 0.10[\pm 0.004]$
General tolerances: $\pm 0.50[\pm 0.020]$

Pin-Out		
Pin	Mark	
1	ZA1	Zero Adujstment 1
2	ZA2	Zero Adujstment 2
3	FB1	Amplitude Adujstment 1
4	FB2	Amplitude Adujstment 2
6	VD	Power Supply(+)
7	GND	Power Supply(-)
10	Vo+	Voltage Signal Output (+)
12	Vo-	Voltage Signal Output (-)
13	Io-	Current Signal Output (-)
15	Io+	Current Signal Output (+)
22	B	Thermal Resistance Signal Input B
23	B	Thermal Resistance Signal Input B
24	A	Thermal Resistance Signal Input A
Others	NC	Pin to be isolated from circuit

Notes:

- For additional information on Product Packaging please refer to www.mornsun-power.com. The Packaging bag number: 58210008;
- Unless otherwise specified, parameters in this datasheet were measured under the conditions of $T_a=25^{\circ}\text{C}$, humidity<75%RH with nominal input voltage and rated output load;
- All index testing methods in this datasheet are based on company corporate standards;
- The above are the performance indicators of the product models listed in this datasheet. Some indicators of non-standard models will exceed the above requirements. For details, please contact our technical staff.
- We can provide product customization service;
- Products are related to laws and regulations: see "Features" and "EMC";
- Our products shall be classified according to ISO14001 and related environmental laws and regulations, and shall be handled by qualified units.

MORNSUN Guangzhou Science & Technology Co., Ltd.

Address: No. 5, Kehui St. 1, Kehui Development Center, Science Ave., Guangzhou Science City, Huangpu District, Guangzhou, P. R. China
Tel: 86-20-38601850 Fax: 86-20-38601272 E-mail: info@mornsun.cn www.mornsun-power.com