

Residual Current Transducer

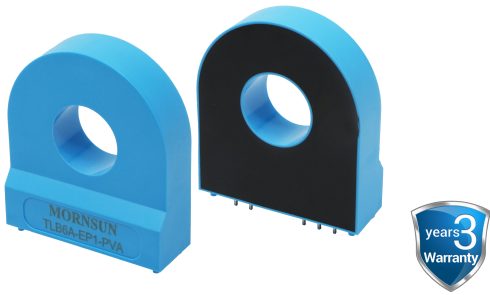

Patent Protection RoHS

Features

- Type B (suitable for type A+6) residual current transducer for charging pile
- Meet the basic residual current operation characteristics of IEC 62423(GB/T 22794)
- Meets the requirements of IEC 62752(GB/T 41589) Mode 2 residual current operating characteristics
- Meets the residual current operating requirements of IEC 62955(GB/T 40820) mode 3 RDC-PD
- Integrated self-check function
- PCB installation, simple application

TLB6A-EP1-PVA is type B (suitable for type A+6) residual current protection module for charging pile, which is widely used in residual current protection of charging facilities of electric vehicles. It uses fluxgate detection technology to detect DC, AC and various pulsating residual current. The module meets the residual current action characteristics requirements of Mode 2 (IEC 62752, GB/T 41589) and Mode 3 (IEC 62955, GB/T 40820), can detect the residual current waveform covering type B, and can detect 6mA DC residual current, the module triggers accurately and responds to leakage events in time.

Selection Guide

Part No.	Input Voltage (VDC)	Rated DC Residual Current (mA)	Rated AC Residual Current (mA)	Rated current (A)	Maximum Power Dissipation(W)
TLB6A-EP1-PVA	5	6	30	80A/40A (1 phase/ 3 phase)	0.21

Electrical Characteristics

Item	Symbol	Min	Typ	Max	Unit.
Rated Residual DC Operating Current	$I_{\Delta NDC}$	--	6	--	mA
Rated Residual AC Operating Current	$I_{\Delta NAC}$	--	30	--	mA
Range of Remaining DC Operating Current	$I_{\Delta NDC-RANGE}$	3	4.5	6	mA
Range of Remaining AC Operating Current	$I_{\Delta NAC-RANGE}$	15	24	30	mA
Input Voltage	V_{DD}	4.85	5	5.15	V
Operating Current	--	--	30	--	mA

Performance Characteristic

Item	Symbol	Residual Current Waveform	Min	Typ	Max	Unit.
Residual Operating Current	$I_{\Delta NAC50}$	50Hz AC	15	23	30	mA RMS
	$I_{\Delta NA0}$	50Hz 0 Angle Pulsating DC	4.5	15	42	mA RMS
	$I_{\Delta NA90}$	50Hz 90 Angle Pulsating DC	6.3	23	42	mA RMS
	$I_{\Delta NA135}$	50Hz 135 Angle Pulsating DC	3.3	28	42	mA RMS
	$I_{\Delta NS-DC}$	Smooth DC	3	4.5	6	mA RMS
	$I_{\Delta N2PDC}$	50Hz Two Phase Rectification DC	3.5	5.3	7	mA RMS
	$I_{\Delta N3PDC}$	50Hz Three Phase Rectification DC	3.1	4.6	6.2	mA RMS
	$I_{\Delta NF}$	Composite Current	15	33	42	mA RMS

Performance Characteristic

Item	Symbol	Residual Current Waveform	Min	Typ	Max	Unit.
Response Time	$T_{\Delta NAC50@30mA}$	RMS 30mA, Frequency 50Hz AC	--	60	200	ms
	$T_{\Delta NAC50@60mA}$	RMS 60mA, Frequency 50Hz AC	--	30	100	ms
	$T_{\Delta NAC50@150mA}$	RMS 150mA, Frequency 50Hz AC	--	15	40	ms
	$T_{\Delta NAC50@5A-100A}$	RMS 5A-100A, Frequency 50Hz AC	--	15	40	ms
	$T_{\Delta A0@42mA}$	RMS 42mA 0 Angle Pulsating DC	--	38	200	ms
	$T_{\Delta A0@84mA}$	RMS 84mA 0 Angle Pulsating DC	--	30	100	ms
	$T_{\Delta A0@210mA}$	RMS 210mA 0 Angle Pulsating DC	--	25	40	ms
	$T_{\Delta A0@42mA+S-DC@6mA}$	RMS 42mA 0 Angle Pulsating DC with 6mA Smooth DC	--	38	200	ms
	$T_{\Delta A0@84mA+S-DC@6mA}$	RMS 84mA 0 Angle Pulsating DC with 6mA Smooth DC	--	30	100	ms
	$T_{\Delta A0@210mA+S-DC@6mA}$	RMS 210mA 0 Angle Pulsating DC with 6mA Smooth DC	--	25	40	ms
	$T_{\Delta S-DC@6mA}$	6mA Smooth DC	--	300	1000	ms
	$T_{\Delta S-DC@60mA}$	60mA Smooth DC	--	25	200	ms
	$T_{\Delta S-DC@300mA}$	300mA Smooth DC	--	25	40	ms
	$T_{\Delta 2/3PDC@60mA}$	RMS 60mA Two Phase/Three Phase Rectification DC	--	25	200	ms
	$T_{\Delta 2/3PDC@120mA}$	RMS 120mA Two Phase/Three Phase Rectification DC	--	20	100	ms
	$T_{\Delta 2/3PDC@300mA}$	RMS 300mA Two Phase/Three Phase Rectification DC	--	20	40	ms
	$T_{\Delta 2/3PDC@5A-100A}$	RMS 5A-100A Two Phase/Three Phase Rectification DC	--	15	40	ms
	$T_{\Delta F@210mA}$	RMS 210mA Composite Current	--	15	40	ms

Protection and Detection Characteristics

Item	Symbol	Min	Typ	Max	Unit.
Self Check TEST_IN Input Low Level Voltage	$V_{TEST-IN IL}$	0	--	1	V
Self Check TEST_IN Input High Level Voltage	$V_{TEST-IN IH}$	4	--	VDD	V
Calibrate the CAL input Low Level voltage	V_{CAL-IL}	0	--	1	V
Calibrate the CAL input High Level voltage	V_{CAL-IH}	4	--	VDD	V
Action TRIP outputs the Low Level voltage	$V_{TRIP-OL}$	0	--	0.6	V
Action TRIP outputs a High Level voltage	$V_{TRIP-OH}$	4.5	--	VDD	V

Isolation Characteristics

Item	Operating Conditions	Min	Typ	Max	Unit.
Isolation Test	Primary edge input, secondary output; 50Hz, 1min; leakage current < 1mA	--	--	5	kVAC
Insulation Resistance	500VDC	1	--	--	GΩ

General Characteristics

Item	Symbol	Min	Typ	Max	Unit.
Operating Temperature	T_a	-40	--	+105	°C
Storage Temperature	T_s	-40	--	+105	°C
Storage Humidity	Non-condensing	5	--	95	%RH
Pin Soldering Resistance Temperature	Soldering spot is 1.5mm away from case for 10 seconds	--	--	+300	°C
Weight	m	--	32	--	g
Vibration	--	20-150Hz, 2g (GB2423.10, IEC60068-2-6)			
Overvoltage Category	--	OVC III (IEC61010)			

EMC

EMI	CE	CISPR32/EN55032	CLASS B	
	RE	CISPR32/EN55032	CLASS B	
EMS	ESD	IEC/EN61000-4-2	Contact ±6kV, Air ±8kV	perf. Criteria A
	EFT	IEC/EN61000-4-4	±2kV	perf. Criteria A
	Surge Current	IEC62955	6000V/2Ω/3000A, 8/20us	perf. Criteria B

Product Characteristic Curve

TLB6A-EP1-PVA Module performance

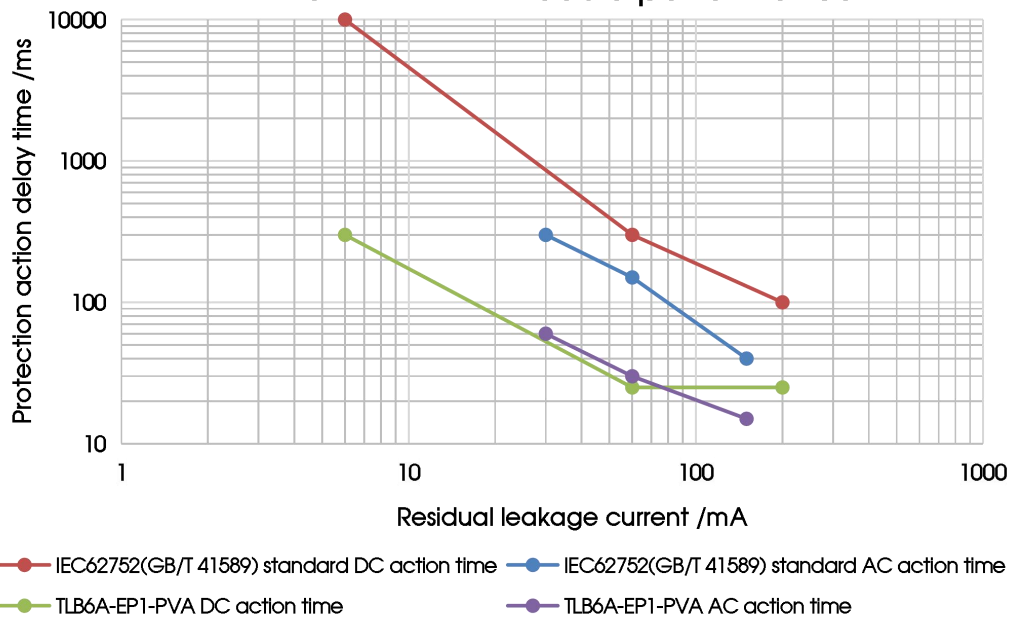

Pin Description

Pin	Mark	Description
1	VDD	➤Product power supply pin ➤Input voltage range is required to be 4.85-5.15V with 100nF and 1uF capacitors in parallel at the input end
2	TRIP	➤Trip output pin. When the residual current in the line is detected to exceed the threshold, the pin is set high to generate a trip signal
3	GND	➤Product power grounding pin
4	CAL	➤Zero calibration pin, when the pin inputs a duration low voltage, the calibration function is enabled and the residual current detected at the moment is used as the zero current point of the residual current compensated for subsequent detection. This residual current compensation value is stored internally and continues to be compensated upon reboot.
5	TEST-IN	➤Self-test test pin, when the pin input sustained high power level, the product will conduct a self-test test, so that TRIP output a high level pulse signal

Connection and Description

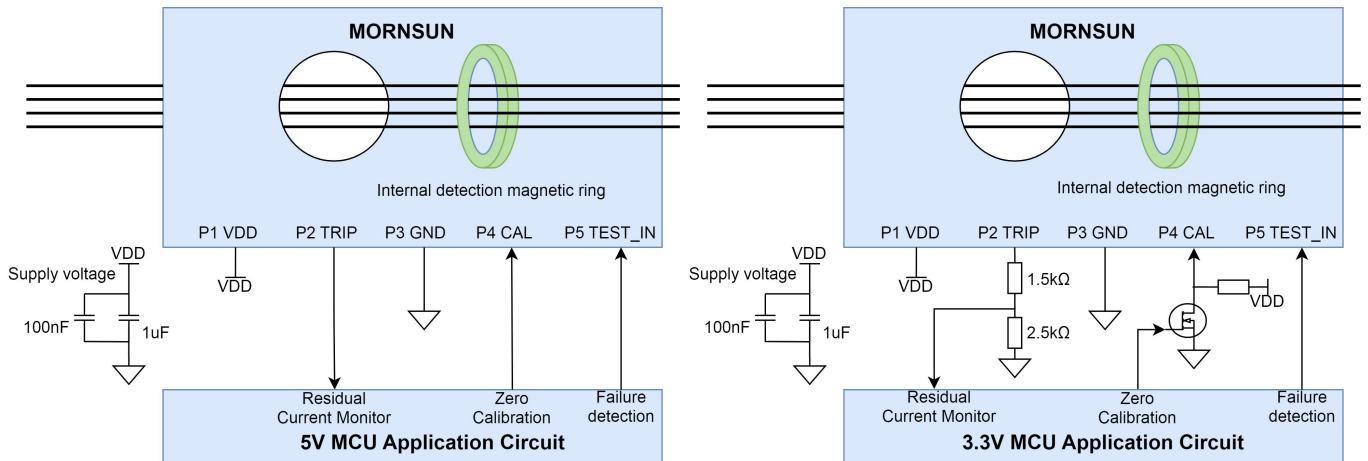

- Two capacitors need to be connected between VDD at the product power supply end and GND at the product grounding end for energy storage and decoupling, respectively connecting 1uF/16V capacitor and 100nF/16V capacitor.
- Residual current protection detection pin TRIP, zero calibration pin CAL, TEST pin test-IN are generally controlled by the microcontroller;
- When the current value flowing through the internal detection magnetic ring exceeds the specification value, the residual current protection detection pin TRIP output high level;
- When the module is started, it is recommended to keep the zero calibration pin CAL low for a period of time and then set the high level (see timing characteristic description) to carry out system calibration and eliminate system interference and residual current;
- TEST pin test-IN is used to test the performance of the residual current protection module when self-test is required, and the test signal needs to meet the timing characteristics;
- The product does not support hot swapping;
- When the product is connected to 5V powered MCU, it is necessary to pay attention to level matching. If a 3.3V powered MCU is connected, the above level conversion circuit needs to be used for voltage conversion, and the 5V voltage is converted to 3.3V through two partial voltage resistors. Generally, the ratio of the two partial voltage resistors is close to 3:5. At the same time, the input impedance of the MCU should be considered, and the resistance value of the two partial voltages should not be greater than one-tenth of the input impedance of the MCU. For example, the value of two partial voltage resistors can be 1.5kΩ and 2.5kΩ, or both 10kΩ and 15kΩ. At the same time, the zero-point calibration function needs to adjust the level logic. When the 3.3V periphery of the MCU is connected, the MOS tube is used for level conversion, and the opposite logic is used for control.
- This product is susceptible to magnetic interference, it is recommended that the main circuit switching relay be placed away from the product.

Timing Characteristics

Item	Symbol	Min	Typ	Max	Unit.
Power-on stability time	T1	600	--	--	ms
Calibration instruction time	T2	50	--	100	ms
Complete internal calibration time	T3	--	500	--	ms
Self-check instruction duration	T4	600	--	--	ms

Timing Application Design

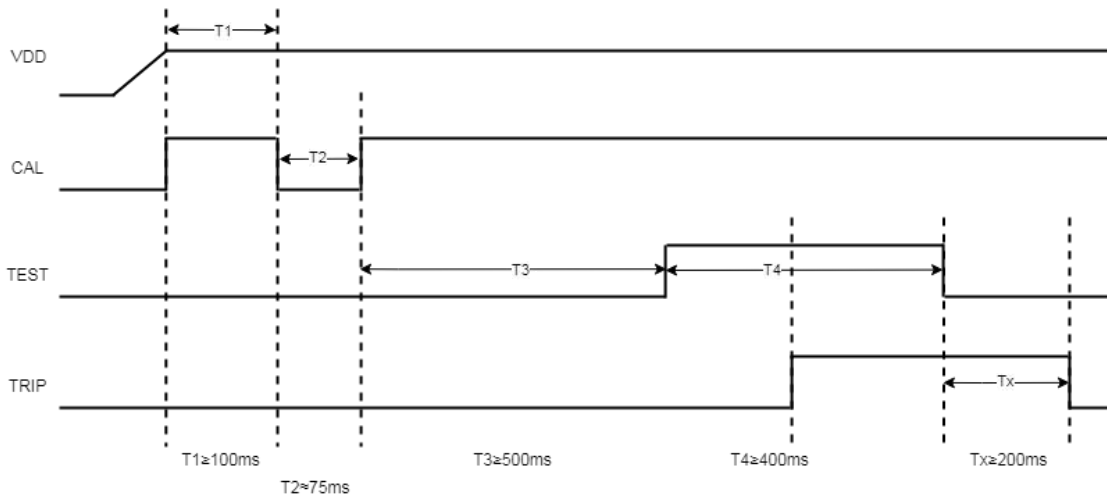

Design essentials:

1. It is recommended that the power supply VDD start from 0V, and the power-on process is monotonous without overshoot;
2. T1 indicates the stability period after power-on. Wait for T1 to reach 600ms or more;
3. T2 is the system calibration instruction time, calibration signal duration $50\text{ms} \leq T2 \leq 100\text{ms}$, it is recommended that CAL duration T2 is 75ms
4. T3 is the internal calibration time of the system, and the calibration signal duration is $T3 \geq 500\text{ms}$;
5. T4 is the duration of system self-test instruction, and the test-IN self-test TEST signal can only be applied after T3 is completed. When the duration of test-IN signal is about 140ms, TRIP is set high, and it is recommended that the duration of self-test command signal $T4 \geq 600\text{ms}$;
6. After the module TRIP is set to high level, the TEST-IN can be set to low level. After the TEST-IN signal is turned off, the TRIP pin high level returns to low level after 200-300ms, and the residual current detection is required after 350ms.

➤Note:

- ① In the process of self-test and calibration, that is, (T1+T2+T3+T4) process, do not close the main loop charging switch, so as to avoid residual residual current after switching on affecting the module self-test and calibration function. After the self-check and calibration function is completed, the RCD module is judged to be normal when the TRIP pin is turned over to a high level, and the self-check signal is removed. After the TRIP pin returns to a low level, the subsequent residual current detection operation is carried out;
- ② After completing the above calibration and self-test after starting, it is not recommended to continue calibration and self-test during normal operation.

Dimensions and Recommended

THIRD ANGLE PROJECTION 

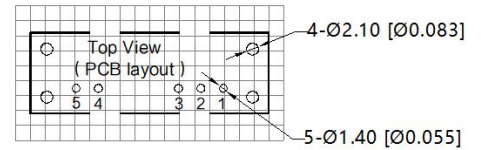
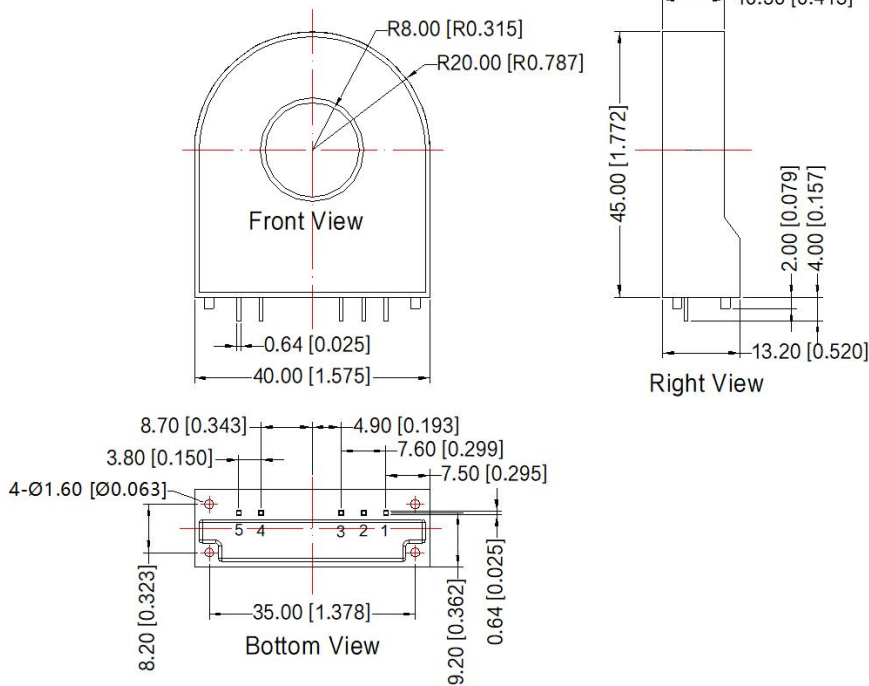

Note: Grid 2.54*2.54mm

Pin-Out	
Pin	Mark
1	VDD
2	TRIP
3	GND
4	CAL
5	TEST-IN

Note:

Unit: mm[inch]

Pin diameter tolerances: $\pm 0.10 [\pm 0.004]$

General tolerances: $\pm 0.50 [\pm 0.02]$

Notes:

1. For additional information on Product Packaging please refer to www.mornsun-power.com. Packaging bag number: 58070031;
2. All index testing methods in this datasheet are based on company corporate standards;
3. Unless otherwise specified, parameters in this datasheet were measured under the conditions of $T_a=25^\circ\text{C}$, humidity<75%RH with nominal input voltage;
4. We can provide product customization service, please contact our technicians directly for specific information;
5. This products is used in electronic equipment, please follow the operation and instructions of the manual, and use it in a standard and safe environment;
6. Please do not install the product in a dangerous area; beware of the risk of electric shock during operating, some modules may generate dangerous voltages (such as primary wires, power supply wires);
7. This products is a build-in device, After installation, the conductive part must not be touched completely. A protective box or shield can be used;
8. It is strictly forbidden to disassemble and assemble the products privately to prevent equipment without failure or malfunction;
9. Our products shall be classified according to ISO14001 and related environmental laws and regulations, and shall be handled by qualified units.

MORNSUN Guangzhou Science & Technology Co., Ltd.

Address: No. 8 Nanyun 4th Road, Huangpu District, Guangzhou, China

Tel: 86-20-38601850

Fax: 86-20-38601272

E-mail: info@mornsun.cn

www.mornsun-power.com