

Residual Current Transducer

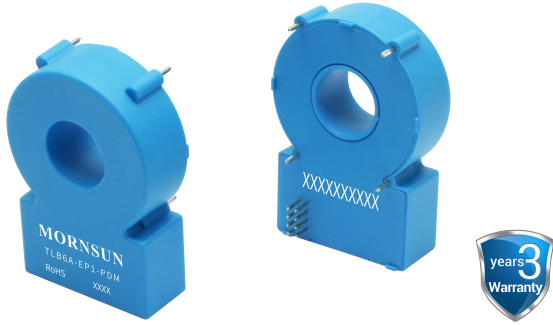

Patent Protection **RoHS**

Features

- Type B (suitable for type A+6) residual current transducer for charging pile
- Meet the basic residual current operation characteristics of IEC 62423(GB/T 22794)
- Meets the requirements of IEC 62752(GB/T 41589) Mode 2 residual current operating characteristics
- Meets the residual current operating requirements of IEC 62955(GB/T 40820) mode 3 RDC-PD
- Horizontal plug-in type, simple application
- 3000A inrush current protection capability

TLB6A-EP1-PDM is type B (suitable for type A+6) residual current protection module for charging pile, which is widely used in residual current protection of charging facilities of electric vehicles. It uses fluxgate detection technology to detect DC, AC and various pulsating residual current. The module meets the residual current action characteristics requirements of Mode 2 (IEC 62752, GB/T 41589) and Mode 3 (IEC 62955, GB/T 40820), can detect the residual current waveform covering type B, and can detect 6mA DC residual current, the module triggers accurately and responds to leakage events in time.

Selection Guide

Part No.	Input Voltage (VDC)	Rated DC Residual Current (mA)	Rated AC Residual Current (mA)	Rated current (A)	Maximum Power Dissipation(W)
TLB6A-EP1-PDM	5	6	30	40A/80A (1 phase/ 3 phase)	0.21

Electrical Characteristics

Item	Symbol	Min	Typ	Max	Unit.
Rated Residual DC Operating Current	$I_{\Delta NDC}$	--	6	--	mA
Rated Residual AC Operating Current	$I_{\Delta NAC}$	--	30	--	mA
Range of Remaining DC Operating Current	$I_{\Delta NDC-RANGE}$	3	--	6	mA
Range of Remaining AC Operating Current	$I_{\Delta NAC-RANGE}$	15	--	30	mA
Input Voltage	V_{CC}	4.85	5	5.15	V
Static Operating Current	--	--	25	--	mA

Performance Characteristic

Item	Symbol	Residual Current Waveform	Min	Typ	Max	Unit.
Operating Current	$I_{\Delta NAC50}$	50Hz AC	15	23	30	mA RMS
	$I_{\Delta NA0}$	50Hz 0 Angle Pulsating DC	4.5	15	42	mA RMS
	$I_{\Delta NA90}$	50Hz 90 Angle Pulsating DC	6.3	23	42	mA RMS
	$I_{\Delta NA135}$	50Hz 135 Angle Pulsating DC	3.3	28	42	mA RMS
	$I_{\Delta NS-DC}$	Smooth DC	3	4.5	6	mA RMS
	$I_{\Delta N2PDC}$	50Hz Two Phase Rectification DC	3.5	5.3	7	mA RMS
	$I_{\Delta N3PDC}$	50Hz Three Phase Rectification DC	3.1	4.6	6.2	mA RMS
	$I_{\Delta NF}$	Composite Current	15	33	42	mA RMS

Performance Characteristic

Item	Symbol	Residual Current Waveform	Min	Typ	Max	Unit.
Response Time	T _{ΔNAC50@30mA}	RMS 30mA, Frequency 50Hz AC	--	60	200	ms
	T _{ΔNAC50@60mA}	RMS 60mA, Frequency 50Hz AC	--	30	100	ms
	T _{ΔNAC50@150mA}	RMS 150mA, Frequency 50Hz AC	--	15	40	ms
	T _{ΔNAC50@5A-100A}	RMS 5A-100A, Frequency 50Hz AC	--	15	40	ms
	T _{ΔA0@42mA}	RMS 42mA 0 Angle Pulsating DC	--	38	200	ms
	T _{ΔA0@84mA}	RMS 84mA 0 Angle Pulsating DC	--	30	100	ms
	T _{ΔA0@210mA}	RMS 210mA 0 Angle Pulsating DC	--	25	40	ms
	T _{ΔA0@42mA+S-DC@6mA}	RMS 42mA 0 Angle Pulsating DC with 6mA Smooth DC	--	38	200	ms
	T _{ΔA0@84mA+S-DC@6mA}	RMS 84mA 0 Angle Pulsating DC with 6mA Smooth DC	--	30	100	ms
	T _{ΔA0@210mA+S-DC@6mA}	RMS 210mA 0 Angle Pulsating DC with 6mA Smooth DC	--	25	40	ms
	T _{ΔS-DC@6mA}	6mA Smooth DC	--	300	1000	ms
	T _{ΔS-DC@60mA}	60mA Smooth DC	--	25	200	ms
	T _{ΔS-DC@300mA}	300mA Smooth DC	--	25	40	ms
	T _{Δ2/3PDC@60mA}	RMS 60mA Two Phase/Three Phase Rectification DC	--	25	200	ms
	T _{Δ2/3PDC@120mA}	RMS 120mA Two Phase/Three Phase Rectification DC	--	20	100	ms
	T _{Δ2/3PDC@300mA}	RMS 300mA Two Phase/Three Phase Rectification DC	--	20	40	ms
	T _{Δ2/3PDC@5A-100A}	RMS 5A-100A Two Phase/Three Phase Rectification DC	--	15	40	ms
	T _{ΔF@210mA}	RMS 210mA Composite Current	--	15	40	ms

Protection and Detection Characteristics

Item	Symbol	Min	Typ	Max	Unit.
Calibration Test Input Low Level Voltage	V _{TESTIN IL}	0	--	1	V
Calibration Test Input High Level Voltage	V _{TESTIN IH}	4	--	5.15	V
Error Output Low Level Voltage	V _{ERROR-OUT OL}	0	--	0.6	V
Error Output High Level Voltage	V _{ERROR-OUT OH}	--	--	High Impedance	--
Operating Output Low Level Voltage	V _{X6-OUT/ X30-OUT OL}	0	--	0.6	V
Operating Output High Level Voltage	V _{X6-OUT/ X30-OUT OH}	--	--	High Impedance	--
PWM Output Duty Ratio	SPWM-OUT	--	3.3	--	%/mA
Frequency of PWM Output Duty Ratio	f _{PWM-OUT}	7.8	8	8.2	kHz

Isolation Characteristics

Item	Operating Conditions	Min	Typ	Max	Unit.
Isolation Test	Primary edge input, secondary output; 50Hz, 1min; leakage current<1mA	--	--	4	kVAC
Pulse Withstand Voltage	1.2/50 μs	--	5.5	--	kV
Insulation Resistance	500VDC	1	--	--	G Ω

General Characteristics

Item	Symbol	Min	Typ	Max	Unit.
Operating Temperature	T _a	-40	--	+105	°C
Storage Temperature	T _s	-40	--	+115	°C
Pin Soldering Resistance Temperature	Soldering spot is 1.5mm away from case for 10 seconds	--	--	+300	°C
Weight	m	--	18	--	g
Vibration	--	20-150Hz, 2g (GB2423.10, IEC60068-2-6)			
Overvoltage Category	--	OVC III (IEC61010)			

EMC

EMI	CE	CISPR32/EN55032	CLASS B	
	RE	CISPR32/EN55032	CLASS B	
EMS	ESD	IEC/EN61000-4-2	Contact $\pm 4kV$, Air $\pm 8kV$	perf. Criteria A
	EFT	IEC/EN61000-4-4	$\pm 2kV$	perf. Criteria A
	Surge Current	IEC62955	6000V/2 Ω /3000A, 8/20 μs	perf. Criteria B

Product Characteristic Curve

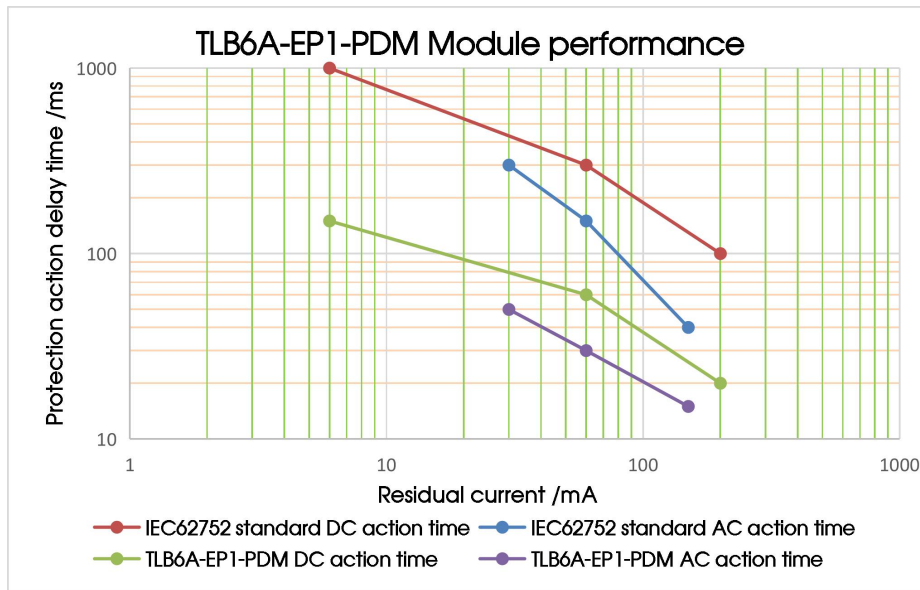

Pin Description

Pin	Mark	Description
1	ERROR-OUT	<ul style="list-style-type: none"> ➢ Error output pin, when the pin is in the high impedance, it indicates that the system is faulty. At this time, the X6-OUT pin and the X30-OUT pin are also in the high impedance. ➢ If the system is normal, the pin is low level.
2	TEST-IN	➢ Calibration Test pin.
3	X6-OUT	<ul style="list-style-type: none"> ➢ Dc action pin. When the system is free of faults, when the DC residual current is less than 3mA, this pin is at a low level; when it is greater than 6mA, this pin is in a high-resistance state. ➢ In addition, when the X30-OUT pin is in a high impedance, the pin is also set to a high impedance. See "Output pin truth Table".
4	X30-OUT	➢ Exchange action pins. When the system is free of faults, when the AC residual current is less than 15mA, this pin is at a low level; when it is greater than 30mA, this pin is in a high-resistance state.
5	GND	➢ Product-powered ground.
6	VCC	➢ The product is powered by VCC, which requires a capacitor of 100nF and 1 μ F in parallel at the input end.
7	PWM-OUT	➢ Duty ratio output pin. Output a square wave signal with 8kHz frequency, and the duty ratio varies with the input current by 3.3% per mA.
8	NC	➢ Not connected.

Output Pin Truth Table

Pin	X6-OUT	X30-OUT	ERROR-OUT	Operating State
Pin Output State	Low level	Low level	Low level	Normal state
	High impedance	Low level	Low level	$I_{\Delta NDC} > 6mA$
	High impedance	High impedance	Low level	$I_{\Delta NAC} > 30mA$
	High impedance	High impedance	High impedance	Error, system fault

Connection and Description

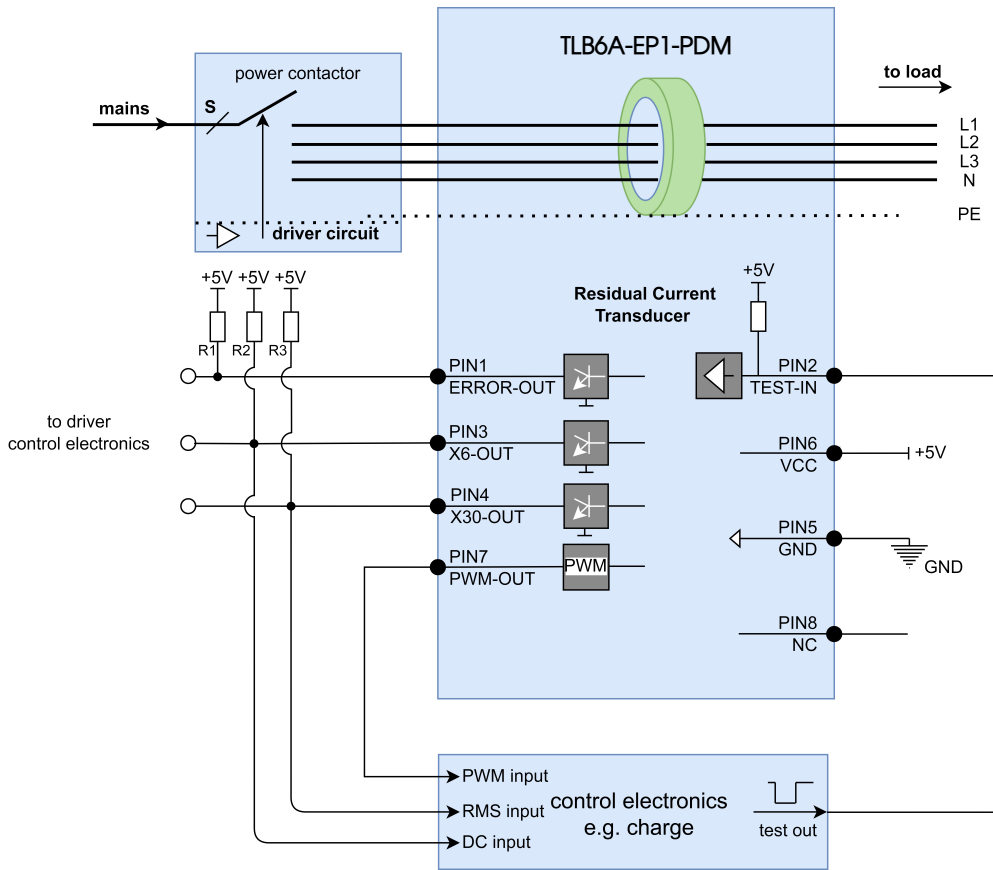

1. The VCC is connected to a 5V power supply.
2. DC action pin X6-OUT, AC action pin X30-OUT and duty ratio output pin PWM-OUT are usually connected to a microcontroller or to a power circuit to control back-end circuit breaker action.
3. The ERROR output pin ERROR-OUT, DC action pin X6-OUT, and AC action pin X30-OUT need to be connected to pull-up resistors R1, R2, and R3 respectively. 10 kΩ is recommended for pull-up resistors.
4. Calibration Test pin TEST-IN is generally controlled by a microcontroller. See "Pin Description" for details.
5. Hot plug is unavailable.
6. The product should pay attention to level matching and use 5V MCU. If 3.3V MCU is used, the pull-up resistors R1, R2, and R3 need to be connected to a 3.3V power supply.

Timing Characteristics

Item	Symbol	Min	Typ	Max	Unit.
Power-on stability time	T1	600	--	--	ms
Calibration instruction time	T2	50	--	100	ms
Calibrate and wait for the DC self-check time	T3	500	--	--	ms
Calibration and wait for the AC self-check time	T4	900	--	--	ms
The duration of AC self-check trip	T5	--	1000	--	ms
The duration of DC self-check trip	T6	--	1400	--	ms

Timing Application Design

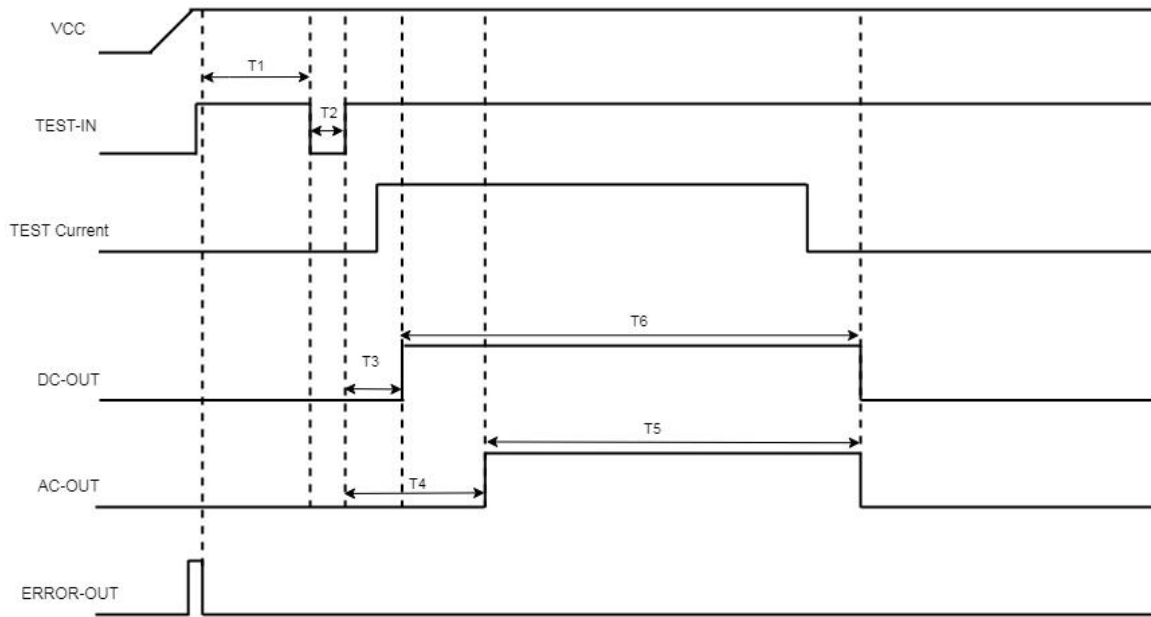

Design essentials:

1. It is recommended that the power supply VCC starts from 0V, and the power-on process is monotonous without overshoot.
2. T1 is the stabilization time after power-on is completed. The waiting time T1 should be $\geq 600\text{ms}$. During this period, it is recommended that the entire system remain inactive.
3. T2 represents the time of the system calibration command. The duration of the calibration signal is $50\text{ms} \leq T2 \leq 100\text{ms}$. It is recommended that the duration of CAL T2 be 75ms.
4. T3 is the time for the system to complete internal calibration and wait for the DC self-check. It is recommended to read the DC-OUT after $T3 \geq 500\text{ms}$.
5. T4 is the time for the system to complete internal calibration and wait for AC self-check. It is recommended to read AC-OUT after $T4 \geq 900\text{ms}$.
6. T5 represents the duration of the AC-OUT high-impedance state, with $T5 \approx 1000\text{ms}$.
7. T6 represents the duration of the DC-OUT high-impedance state, with $T6 \approx 1400\text{ms}$.

Note:

- ① During the calibration process, that is, during the $(T1+T2+T3+T6)$ process, do not close the main circuit charging switch to avoid residual current after connection affecting the module's self-check and calibration functions. After the calibration is completed and the DC-OUT and AC-OUT pins are flipped to the high-impedance state, it is judged that the RCD module is normal. Wait for the DC-OUT and AC-OUT pins to return to the low level before performing the subsequent residual current detection operation.
- ② Complete the above calibration after startup. It is not recommended to continue the calibration during normal operation.

Dimensions and Recommended

THIRD ANGLE PROJECTION 

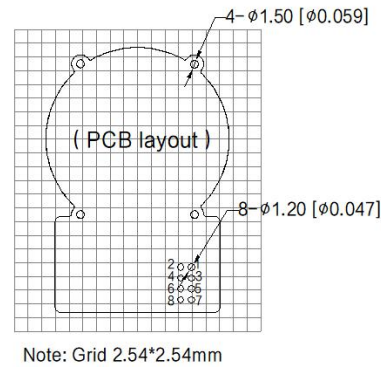
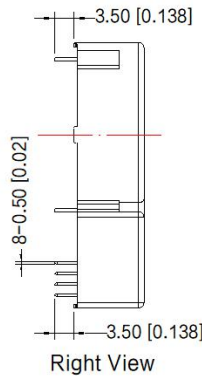
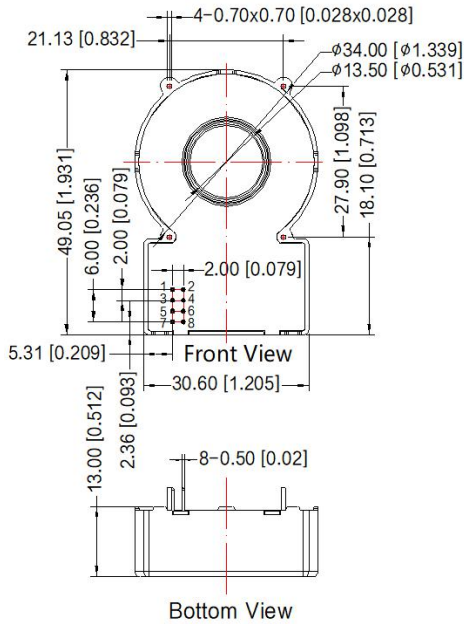

Pin-Out	
Pin	Mark
1	ERROR-OUT
2	TEST-IN
3	X6-OUT
4	X30-OUT
5	GND
6	VCC
7	PWM-OUT
8	NC

Note:
Unit: mm[inch]
Pin diameter tolerances: $\pm 0.15[\pm 0.006]$
General tolerances: $\pm 0.50[\pm 0.02]$

Notes:

1. For additional information on Product Packaging please refer to www.mornsun-power.com. Packaging bag number: 58240085;
2. All index testing methods in this datasheet are based on company corporate standards;
3. Unless otherwise specified, parameters in this datasheet were measured under the conditions of $T_a=25^\circ\text{C}$, humidity<75%RH with nominal input voltage;
4. We can provide product customization service, please contact our technicians directly for specific information;
5. This products is used in electronic equipment, please follow the operation and instructions of the manual, and use it in a standard and safe environment;
6. Please do not install the product in a dangerous area; beware of the risk of electric shock during operating, some modules may generate dangerous voltages (such as primary wires, power supply wires);
7. This products is a build-in device, After installation, the conductive part must not be touched completely. A protective box or shield can be used;
8. It is strictly forbidden to disassemble and assemble the products privately to prevent equipment without failure or malfunction;
9. Our products shall be classified according to ISO14001 and related environmental laws and regulations, and shall be handled by qualified units.

MORNSUN Guangzhou Science & Technology Co., Ltd.

Address: No. 8 Nanyun 4th Road, Huangpu District, Guangzhou, China

Tel: 86-20-38601850

Fax: 86-20-38601272

E-mail: info@mornsun.cn

www.mornsun-power.com