

TD541S485H-A DFN package isolated RS485 Transceiver

Features

- Ultra-small, ultra-thin, chip scale DFN package
- Compliant with TIA/EIA-485-A standard
- Integrated isolated 5V power
- I/O power supply range supports 3.3V and 5V microprocessors(Specific application refer to “ Use Suggestion ②”)
- High isolation to 5000VDC
- Bus-Pin ESD protection up to 15kV(HBM)
- Baud rate up to 500kbps
- >25kV/us CMTI
- Automatic send and receive data function
- 1/8 unit load—up to 256 nodes on a bus
- Bus fail-safe
- Bus driver short circuit protection
- Industrial operating ambient temperature range: -40°C to +105°C
- Moisture Sensitivity Level (MSL) 3

Package

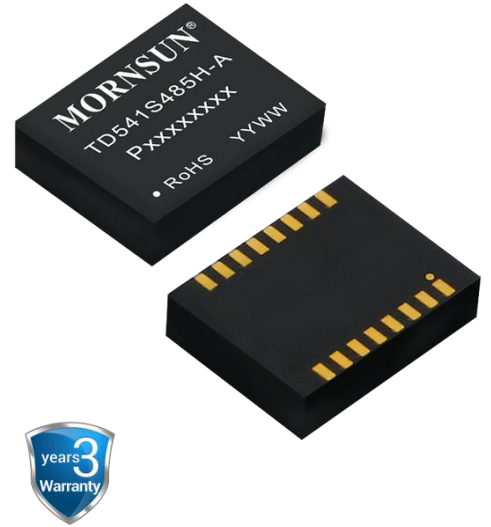

Applications

- Industrial Automation
- Building Automation
- Smart Electricity Meter
- Remote Signal Interaction, Transmission

Functional Description

TD541S485H-A is a half-duplex enhanced transceiver designed for RS-485 data bus networks, which is fully compliant with TIA/EIA-485-A standard and is suitable for data transmission of up to 500kbps. In addition, the product features an automatic switching function, that no longer requires the need to pass through the node to send and receive control signals, which to a certain extent, reduces the design complexity. Their logic side supports 3.3V and 5V logic level conversion. Receivers have an exceptionally high input impedance, which places only 1/8 of the standard load on a shared bus and up to 256 transceivers.

The reliability design of A and B pin is emphasized, including driver output over current protection and enhanced ESD design. The ESD protection level of A, B pin can be up to 15kV (Human Body Model).

Contents

<p>1 Home.....1</p> <p> 1.1 Feature and Package.....1</p> <p> 1.2 Applications.....1</p> <p> 1.3 Functional Description.....1</p> <p>2 Pin Connection and Description.....2</p> <p>3 IC Related Parameters.....3</p> <p> 3.1 Absolute Maximum Rating.....3</p> <p> 3.2 Recommended Operating Conditions.....3</p> <p> 3.3 Electrical Characteristics.....4</p> <p> 3.4 Transmission Characteristics.....5</p> <p> 3.5 Physical Characteristics.....5</p>	<p>4 Characteristic Curve.....5</p> <p> 4.1 Typical Performance Curve.....5</p> <p> 4.2 Parameter Measurement Information.....5</p> <p>5 Product working Description.....6</p> <p>6 Application Circuit.....7</p> <p>7 Suggestions for Power Supply.....7</p> <p>8 Order Information.....8</p> <p>9 Package Information.....8</p> <p>10 Tape & Reel Information.....9</p>
----------------------------------------------------------------------------------------------------------------------------------------------------------------------------------------------------------------------------------------------------------------------------------------------------------------------------------------------------------------------------------------------------------------------------------------------------------------------------------	-------------------------------------------------------------------------------------------------------------------------------------------------------------------------------------------------------------------------------------------------------------------------------------------------------------------------------------------------------------------------------------

Pin Connection

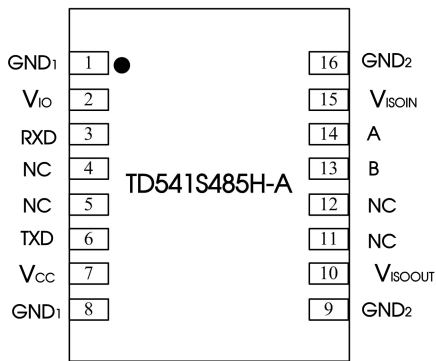

Note: All GND₁ pins are internally connected.
All GND₂ pins are internally connected.

Internal Block

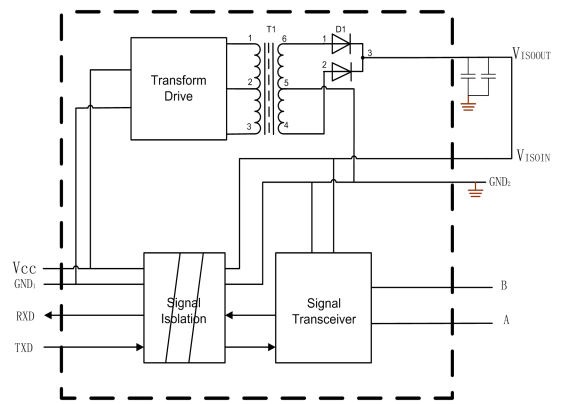

Function Table

Letter	Description
H	High-Level
L	Low-Level
X	Unrelated
Z	High Impedance

Table 1. Driver Function table

Input	Output	
TXD	A	B
H	H	L
L	L	H

Table 2. Receiver Function table

Difference input $V_{ID} = (V_A - V_B)$	RXD
$-0.01\text{ V} \leq V_{ID}$	H
$-0.2\text{ V} < V_{ID} < -0.01\text{ V}$	Uncertainty
$V_{ID} \leq -0.2\text{ V}$	L
Open circuit	H
Short circuit	H

Pin Descriptions

Pin Number	Pin Name	Pin Functions
1	GND ₁	Ground(Logic side).
2	V _{IO}	Power supply. By using 0.1uF ceramic capacitance ground(GND ₁).
3	RXD	Receiver output pin.
4	NC	No Connect.
5	NC	No Connect.
6	TXD	Driver input pin.
7	V _{CC}	Power supply. By using 1uF ceramic capacitance ground(GND ₁).
8	GND ₁	Ground(Logic side).
9	GND ₂	Ground (Bus Side).
10	V _{ISOOUT}	Insulation power output. By using 1uF Ceramic capacitance ground(GND ₂ , pin9).
11	NC	No Connect.
12	NC	No Connect.
13	B	RS485 Bus B Line.
14	A	RS485 Bus A Line.
15	V _{ISOIN}	Insulation power input. By using 0.1uF ceramic capacitance ground(GND ₂ , pin16).
16	GND ₂	Ground (Bus Side).

Absolute Maximum Ratings

General test conditions: Free-air, normal operating temperature range (Unless otherwise specified).

Parameters	Unit
Supply voltage, V _{CC}	-0.3V to +6V
A, B Bus voltage	-8V to +13V
Digital Input Voltage (TXD, RXD)	-0.3V to +6V
Operating Temperature Range	-40°C to +105°C
Storage Temperature Range	-50°C to +125°C
Reflow Soldering Temperature	Peak temp. ≤250°C, maximum duration ≤60s at 217°C. Please also refer to IPC/JEDEC J-STD-020D. 3.

Important: Exposure to absolute maximum rated conditions for an extended period may severely affect the device reliability, and stress levels exceeding the "Absolute Maximum Ratings" may result in permanent damage.

Recommended Operating Conditions

Symbol	Recommended Operating Conditions	Min.	Typ.	Max.	Unit
V _{CC}	Supply voltage	4.5	5	5.5	V
V _I	Voltage at any bus terminal (differential or common mode)	-7		12	
V _{IH}	High-level input voltage(TXD)	2		V _{CC}	
V _{IL}	Low-level input voltage(TXD)	0		0.8	
T _A	Operating temperature range	-40		105	°C
-	Signaling rate			500	kbps

Electrical Characteristics

Symbol	Parameter	Conditions	Min.	Typ.	Max.	Unit
Driver						
$ V_{OD} $	Differential driver output	No load	1.5			V
ΔV_{OD}	$\Delta V_{OD} $ for complementary output states	No load, Figure 6			± 0.2	V
I_{OS}	Output short-circuit current	$-7V \leq V_A$ or $V_B \leq 12V$		± 110	± 250	mA
Receiver						
$V_{IT(+)}$	Positive differential input threshold voltage	$-7V \leq V_A$ or $V_B \leq +12V$			-10	mV
$V_{IT(-)}$	Negative differential input threshold voltage	$-7V \leq V_A$ or $V_B \leq +12V$	-200			mV
V_{hys}	Hysteresis voltage ($V_{IT+} - V_{IT-}$)	$-7V \leq V_A$ or $V_B \leq +12V$		20		mV
R_{ID}	Differential input resistance(A, B)	$-7V \leq V_A$ or $V_B \leq +12V$	96			k Ω
V_{OH}	RXD output high voltage	$I_{OUT} = 4\text{ mA}$, $V_A - V_B = 0.2\text{ V}$	$V_{CC} - 0.4$	$V_{CC} - 0.2$		V
V_{OL}	RXD output low voltage	$I_{OUT} = -4\text{ mA}$, $V_A - V_B = -0.2\text{ V}$			0.4	V
Power supply and safeguard characteristic						
I_{CC}	Supply current	No Load		15	25	mA
I_{CC}	Max. Operating Curren	No Load		14	35	mA
ESD	HBM	A, B to GND			± 15	kV
		Other pin			± 2	kV
EFT	IEC61000-4-4	A, B and GND			± 2	kV
SURGE	IEC61000-4-5	A, B and GND(Common Mode)			± 2	kV
V_{I-O}	Insulate voltage				5000	VDC
	Insulate impedance		1			G Ω
	Insulate capacitance			3		pF
CMTI	Common mode transient immunity	$TXD = V_{CC}$ or 0 V , $V_{CM} = 1\text{ kV}$, transient magnitude = 800 V	25			kV/us

Transmission Characteristics

Symbol	Parameter	Conditions	Min.	Typ.	Max.	Unit
-	Maximum data rate	Duty 40% ~ 60%			500	kbps
T_{PHL} , T_{PLH}	Driver propagation delay	No load, $C_L = 50\text{pF}$, Figure 7			400	ns
T_R , T_F	Driver rise/fall time				100	
T_{PHL} , T_{PLH}	Receiver propagation delay	$C_L = 15\text{pF}$ Figure 8		60	150	
$ T_{PHL} - T_{PLH} $	Receiver skew ($ T_{PLH} - T_{PHL} $)				20	
T_R , T_F	Bus rise/fall time			25		

Physical Characteristics

Parameters	Value	Unit
Weight	0.9(Typ.)	g

Typical Performance Curves

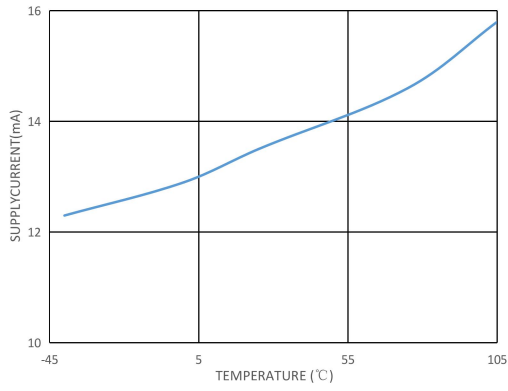

Figure 1. Supply current vs. Temperature

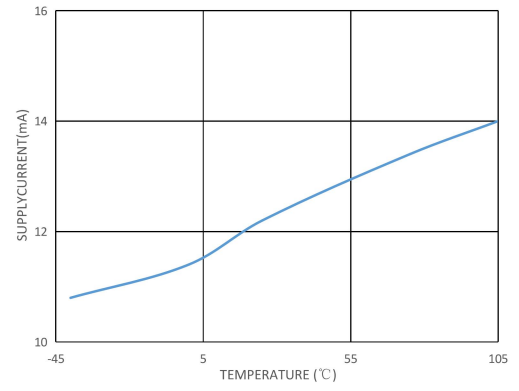

Figure 2. Operating current vs. Temperature

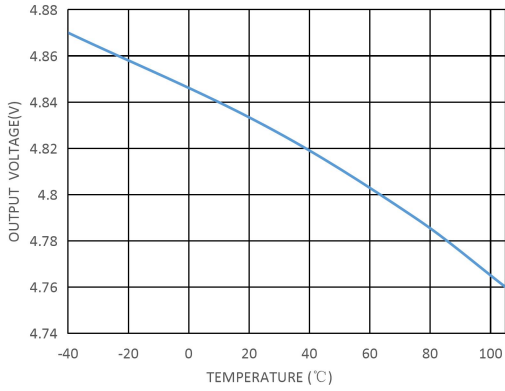

Figure 3. Receiver Output High Voltage vs. Temperature

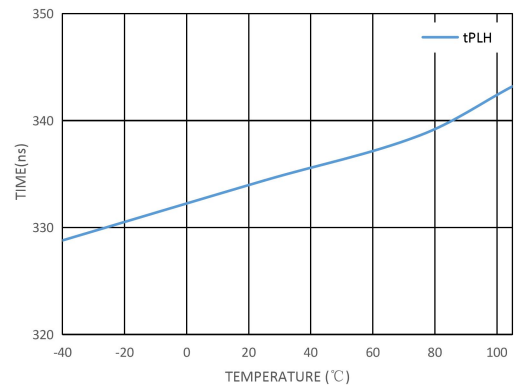

Figure 4. Driver Propagation Delay vs. Temperature

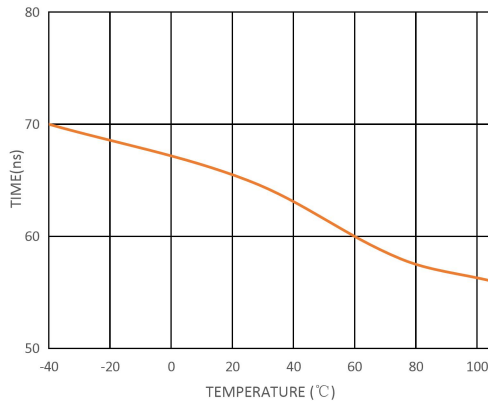

Figure 5. Receiver Propagation Delay vs. Temperature

Test Circuits

Note: Testing the condition burden capacitance including test to stretch forward and testing fixture parasitic capacitance. Testing semaphore upswing and droop to follow < 6ns, frequency 100kHz, duty 50%. resistance $Z_0 = 54\Omega$.

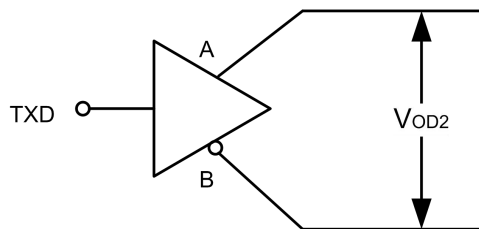

Figure 6. Driver test circuit

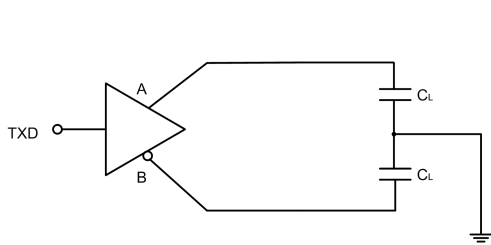

Figure 7. Drive propagation delay test circuit and wave forms

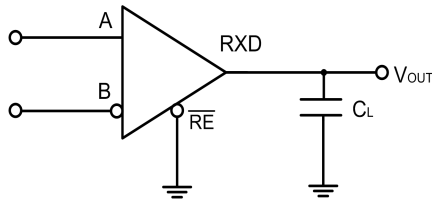
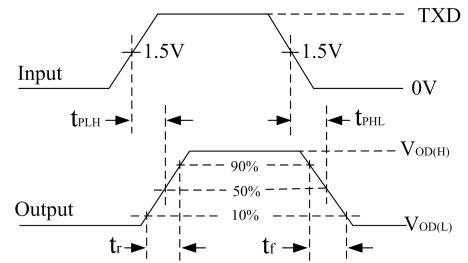
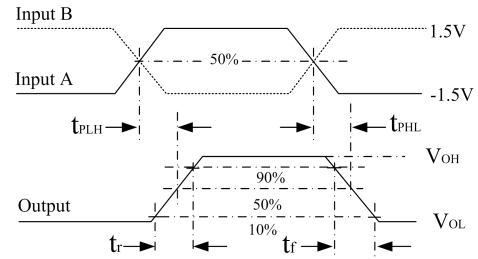

Figure 8. Receiver propagation delay test circuit and wave forms



Detailed Description

TD541S485H-A is a semi-duplex enhanced RS485 isolated transceiver with isolated power supply. In addition to an isolated power supply, each transceiver contains a drive and a receiver. The transceiver has a standby bus failure protection function to ensure that the receiver output is high when the receiver input is open, short, or when the bus is idle. TD541S485H-A adopts 5VDC single power supply. The whole machine can monitor the overall working state of the module and limit the output high current, so as to prevent the bus overload or short circuit from causing non-recoverable damage to the transceiver.

Receiver input filter: TD541S485H-A receiver integrated high performance input filter, the filter can greatly enhance the receiver's noise suppression ability to high speed differential signal. Therefore, the transmission delay of the receiver is also caused by this reason.

Bus failure protection: In general, when $-200\text{mV} < A - B < -10\text{mV}$, the bus receiver will be in an indeterminate state. This phenomenon occurs when the bus is idle. Bus failure protection ensures that the receiver outputs a high level when the receiver input is open, short, or when the bus access port matches the resistance. TD541S485H-A receiver threshold voltage is relatively accurate, and the threshold voltage to the reference ground has a margin of at least 10mV, which can ensure that even if the bus differential voltage is 0V, the receiver output level is high, and meets the requirements of EIA/TIA-485 standard $\pm 200\text{mV}$.

The bus load capacity (256 point): standard RS485 receiver input impedance is defined as 12 k Ω (unit load). A standard RS485 driver can drive at least 32 load units. TD541S485H-A bus receiver designed by 1/8 unit load, the input impedance is greater than 96 k Ω . As a result, the bus allows access to more transceivers (up to 256). TD541S485H-A can also be mixed with the standard RS485 transceiver with 32 unit loads (cumulative receiver load cannot exceed 32 units).

Low power SHUTDOWN mode: When high level is input and low power is input, the transceiver enters SHUTDOWN mode. When the transceiver enters off mode, its overall standby power consumption decreases, DE can be short-connected and controlled by the same I/O. If the high level is input and the holding time of DE low level is less than 50ns, the transceiver cannot enter the off mode. If the holding time can be maintained at least 600ns, the transceiver will reliably enter the off mode.

Drive output protection: TD541S485H-A internal integrated drive short circuit (or overcurrent) protection module. In case of bus error or driver short circuit, the module can limit the output current of the driver within a certain limit.

Automatic switching function: The product integrates an automatic switching unit so that no longer requires the need to pass through DE, RE the node to send and receive control signals, which to a certain extent, reduces the design complexity.

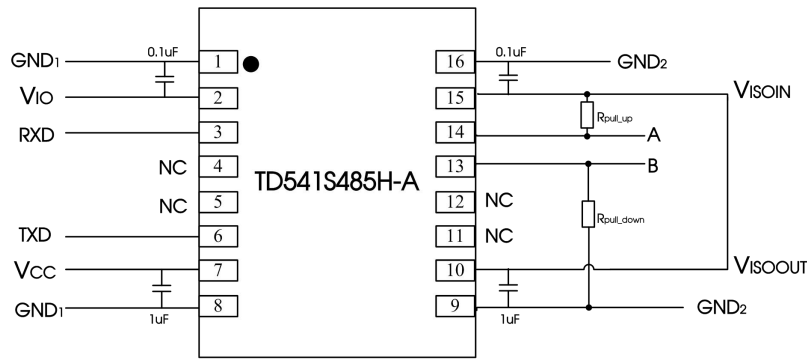

Figure9. Type PCB layout

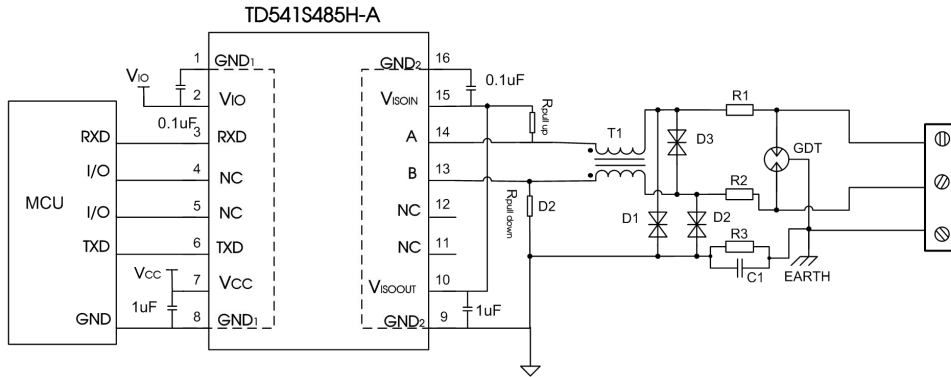

Figure10. Port protection circuit for harsh environments

Recommended components and values:

Component	Recommended part, value	Component	Recommended part, value
R3	1MΩ	R1, R2	2.7Ω/2W
C1	1nF, 2kV	D1, D2	SMBJ6.5CA
T1	ACM2520-301-2P	D3	SMBJ6.5CA
GDT	B3D090L		

As the modules internal A / B lines come with its own ESD protection, which generally satisfy most application environments without the need for additional ESD protection devices. For harsh and noisy application environments such as motors, high voltage/current switches, lightning and similar however, we recommended that the user protects the module's A / B lines with additional measures and external components such as TVS tube, common mode inductors, Gas discharge tube, shielded twisted pair of wires with the same single network Earth point. Figure 12 shows our recommended circuit diagram for such type of applications with components and values given in the table above. This recommendation is for reference only and may have to be adapted accordingly with appropriate component values in order to match the actual situation and application.

Using Suggests

- ① Power isolation V_{ISOOUT} need through a series of capacitors connected to the output pin V_{ISOIN} , in addition to the mentioned in ④ of the pull up and down function, the power supply is not recommended for other purposes, otherwise it may cause the bus voltage did not meet the requirements of communication, causes the communication failure.
- ② V_{IO} pin decide the output level of RXD pin. Normally, V_{IO} pin need to connected to the V_{CC} pin to support 5V microprocessors. V_{IO} pin need to disconnect to the V_{CC} pin and need a 3.3V power supply separately to support 3.3V microprocessors if necessary.
- ③ At no time should the pin of the controller connected to TXD be set to an open-drain output state, otherwise it will cause uncertain consequences.
- ④ To maintain A - B bus idle stability, we need at least one node will pull up A to V_{ISOIN} and drop down B to GND_2 on the bus. Overall network at the same time pull up and drop down resistance of the parallel value must around $400\Omega(0.2W)$.

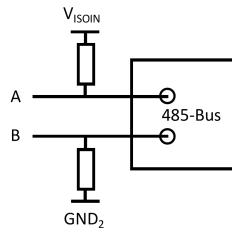

Figure11. Pull up and drop down resistance connect

- ⑤ Hot-swap is not supported.
- ⑥ If the external input of TXD is insufficient, the pull-up resistor should be added according to the situation.
- ⑦ Refer to IPC 7093 for the welding process design of this product. For detailed operation guidance, please refer to Hot Air Gun Welding Operation Instruction for DFN Package Product or Welding Operation Instruction for DFN Package Product.

Ordering Information

Part number	Package	Number of pins	Product marking	Tape & Reel
TD541S485H-A	DFN	16	TD541S485H-A	300/REEL

Package Information

THIRD ANGLE PROJECTION

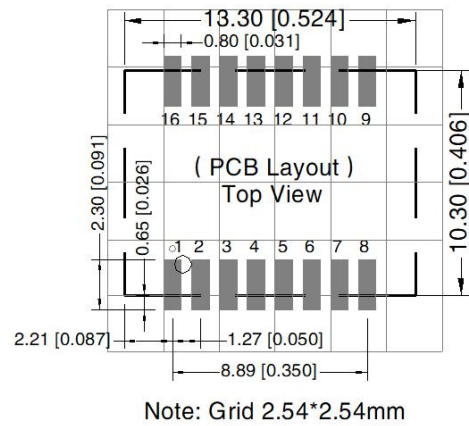
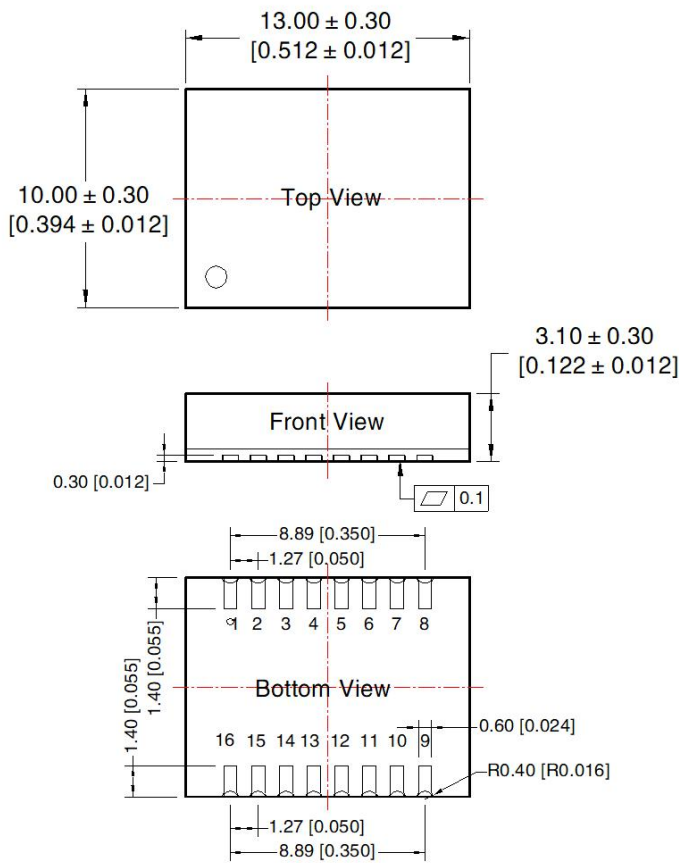

Pin-Out			
Pin	Mark	Pin	Mark
1	GND ₁	9	GND ₂
2	V _{IO}	10	V _{ISOOUT}
3	RXD	11	NC
4	NC	12	NC
5	NC	13	B
6	TXD	14	A
7	V _{CC}	15	V _{ISOIN}
8	GND ₁	16	GND ₂

Note:
Unit: mm[inch]
General tolerances: ± 0.10[± 0.004]

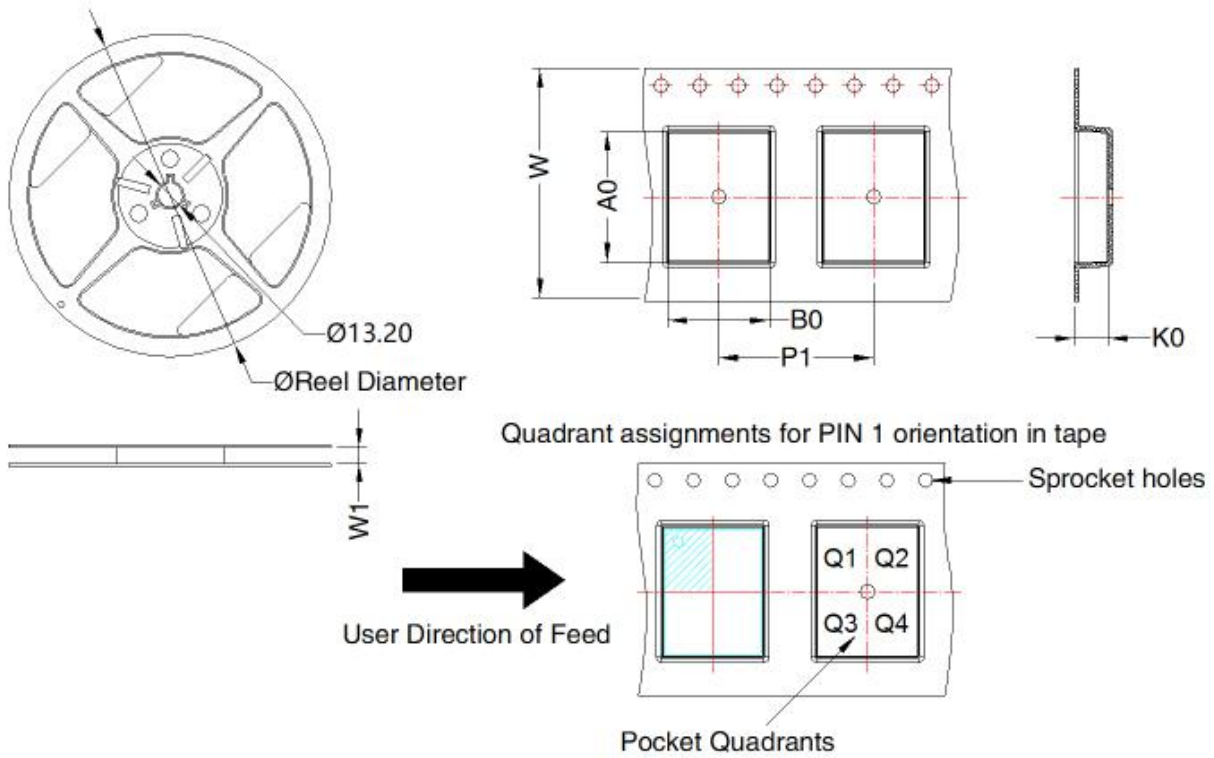

Package Type	Pin	MPQ	Reel Diameter (mm)	Reel Width W1 (mm)	A0 (mm)	B0 (mm)	K0 (mm)	P1 (mm)	W (mm)	Pin1 Quadrant
DFN 10x13	16	300	180.0	24.4	13.52	10.52	3.5	16.0	24.0	Q1

MORNSUN Guangzhou Science & Technology Co., Ltd.

Address: No. 8 Nanyun 4th Road, Huangpu District, Guangzhou, China

Tel: 86-20-38601850

Fax: 86-20-38601272

E-mail: info@mornsun.cn

www.mornsun-power.com