

## TD541S232H DFN package isolated RS232 Transceiver

### Features

- Ultra-small, ultra-thin, chip scale DFN package
- Compliant with TIA/EIA-232 standard
- Integrated isolated 5V power
- I/O power supply range supports 3.3V and 5V microprocessors(RXD can be directly connected when using 5V microprocessor; When using 3.3V microprocessor, please refer to point ③ in "Suggestions for Power Supply".)
- High isolation to 5000VDC
- Bus-Pin ESD protection up to 15kV(HBM)
- Baud rate up to 120kbps
- >25kV/us CMTI
- Industrial operating ambient temperature range: -40°C to +85°C
- Moisture Sensitivity Level (MSL) 3

### Package

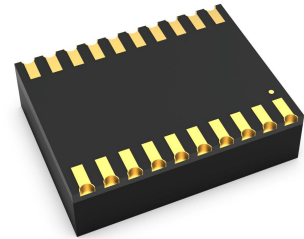

### Applications

- Industrial Automation
- Building Automation
- Smart Electricity Meter

### Functional Description

TD541S232H is a RS232 transceiver with low power consumption and high electrostatic protection and ESD protection, and it is fully compliant with TIA/EIA-232 standards. The main function of the product will be to convert the TTL level to the level of the RS232 protocol to achieve signal isolation. And the product comes with a constant voltage isolation power supply, which can achieve 5000VDC electrical isolation, and can also be easily embedded in user equipment, so that the equipment can easily realize the connection function of the RS232 protocol network.

TD541S232H focuses on strengthening the reliability design of TOUT and RIN pins and enhanced ESD design on the basis of traditional IC. Its TOUT and RIN port ESD tolerance is as high as 15kV (Human Body Model).

# Contents

|     |   |   |     |                                   |   |
|-----|---|---|-----|-----------------------------------|---|
| 1   | Home.....                                   | 1 | 5   | Characteristic Curve.....         | 4 |
| 1.1 | Feature and Package.....                    | 1 | 5.1 | Typical Performance Curve.....    | 6 |
| 1.2 | Applications.....                           | 1 | 6   | Application Circuit.....          | 6 |
| 1.3 | Functional Description.....                 | 1 | 7   | Suggestions for Power Supply..... | 7 |
| 2   | Pin Package and internal block diagram..... | 2 | 8   | Order Information.....            | 7 |
| 3   | Truth table.....                            | 2 | 9   | Package Information.....          | 7 |
| 4   | IC Related Parameters.....                  | 3 | 10  | Tape & Reel Information.....      | 8 |
| 4.1 | Absolute Maximum Rating.....                | 3 |     |                                   |   |
| 4.2 | Recommended Operating Conditions.....       | 3 |     |                                   |   |
| 4.3 | Electrical Characteristics.....             | 4 |     |                                   |   |
| 4.4 | Transmission Characteristics.....           | 4 |     |                                   |   |
| 4.5 | Physical Characteristics.....               | 4 |     |                                   |   |

## Pin Connection

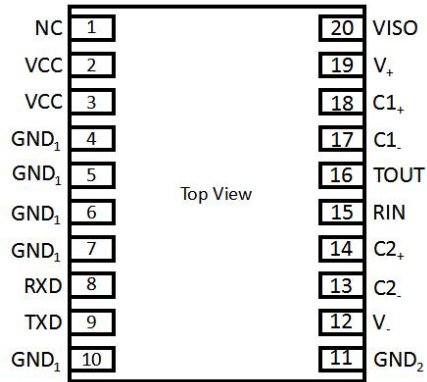

Note: All GND1 pins are internally connected.  
All GND1 pins are internally connected.

## Internal Block

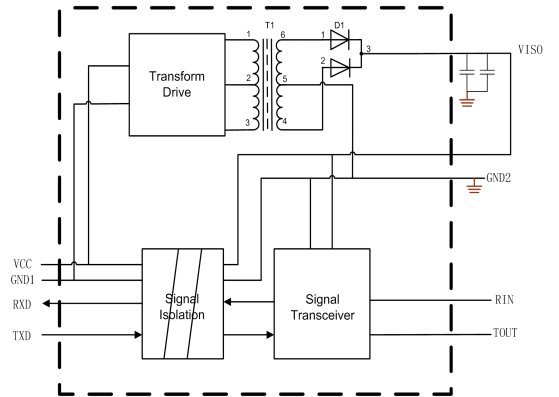

## Function Table

| Letter | Description |
|--------|-------------|
| H      | High-Level  |
| L      | Low-Level   |

Table 1. Driver Function table

| Transceiver function | Input | Output |
|----------------------|-------|--------|
| Send function        | TXD   | T_OUT  |
|                      | L     | H      |
|                      | H     | L      |

Table 2. Receiver Function table

| Transceiver function | Input         | Output      |
|----------------------|---------------|-------------|
| Receive function①    | R_IN          | RXD         |
|                      | ≥2.4V         | L           |
|                      | ≤0.6V         | H           |
|                      | 0.6V≤RXD≤2.4V | Uncertainty |

Note : ①The receiving threshold varies slightly with Vcc.

## Pin Descriptions

| Pin Number | Pin Name         | Pin Functions   |
|------------|------------------|---|
| 1          | NC               | No function pin, can be left floating.  |
| 2          | V <sub>CC</sub>  | Power supply. By using 0.1uF ceramic capacitance ground(GND <sub>1</sub> ).   |
| 3          | V <sub>CC</sub>  | Power supply. By using 0.1uF ceramic capacitance ground(GND <sub>1</sub> ).   |
| 4          | GND <sub>1</sub> | Logic side reference ground.  |
| 5          | GND <sub>1</sub> | Logic side reference ground.  |
| 6          | GND <sub>1</sub> | Logic side reference ground.  |
| 7          | GND <sub>1</sub> | Logic side reference ground.  |
| 8          | RXD              | Receiver signal output pin.   |
| 9          | TXD              | Driver input pin.   |
| 10         | GND <sub>1</sub> | Logic side reference ground.  |
| 11         | GND <sub>2</sub> | Isolated output reference ground.   |
| 12         | V <sub>-</sub>   | Negative power generated internally,this pin is recommended to be connected to the isolated output reference ground(GND <sub>2</sub> ) through a 0.1uF capacitor.   |
| 13,14      | C2-,C2+          | The positive and negative connections of the charge pump capacitor. These two pins are connected to an external capacitor C2, 0.1uF capacitor is recommended.       |
| 15         | RIN              | Receiver input. This input accepts RS-232 signal level.   |
| 16         | TOUT             | Drive output. This pin outputs the RS-232 signal level.   |
| 17,18      | C1-,C1+          | The positive and negative connections of the charge pump capacitor. These two pins are connected to an external capacitor C1, and a 0.1uF capacitor is recommended. |
| 19         | V <sub>+</sub>   | Positive power generated internally,this pin is recommended to be connected to the isolated output reference ground(GND <sub>2</sub> ) through a 0.1uF capacitor.   |
| 20         | V <sub>iso</sub> | Isolated power output terminal, this pin must be connected to the isolated output reference ground(GND <sub>2</sub> ) through a 0.1uF capacitor.                    |

## Absolute Maximum Ratings

General test conditions: Free-air, normal operating temperature range (Unless otherwise specified).

| Parameters                   | Unit   |
|------------------------------|--|
| Supply voltage               | -0.3V to +6V   |
| Driver input pin, TXD        | -0.3V to +6V   |
| Driver output pin, TOUT      | -13.2V to +13.2V   |
| Receiver input pin, RIN      | -25V to +25V   |
| Receiver output pin, RXD     | -0.3V to +6V   |
| Operating Temperature Range  | -40°C to +105°C  |
| Storage Temperature Range    | -50°C to +150°C  |
| Reflow Soldering Temperature | Peak temp. ≤250°C, maximum duration ≤60s at 217°C. Please also refer to IPC/JEDEC J-STD-020D. 3. |

Important: Exposure to absolute maximum rated conditions for an extended period may severely affect the device reliability, and stress levels exceeding the "Absolute Maximum Ratings" may result in permanent damage. All voltage values are based on the reference ground(GND).

## Recommended Operating Conditions

| Symbol          | Recommend an operate condition | Min.     | Typ. | Max.            | Unit |
|-----------------|--------------------------------|----------|------|-----------------|------|
| V <sub>CC</sub> | Supply voltage                 | 4.5      | 5    | 5.5             | V    |
| V <sub>IH</sub> | High-level input voltage(TXD)  | 2        |      | V <sub>CC</sub> |      |
| V <sub>IL</sub> | Low-level input voltage(TXD)   | 0        |      | 0.8             |      |
| I <sub>OS</sub> | Output current                 | Driver   | 2    |                 | mA   |
|                 |                                | Receiver |      |                 |      |
| R <sub>L</sub>  | Output load resistance         |          | 3000 |                 | Ω    |
| T <sub>A</sub>  | Operating temperature range    | -40      |      | 85              | °C   |
| -               | Signaling rate                 |          |      | 120             | Kbps |

## Electrical Characteristics

| Symbol   | Parameter                             | Conditions  | Min.                  | Typ.                  | Max. | Unit  |
|--|---------------------------------------|---|-----------------------|-----------------------|------|-------|
| <b>Driver</b>                                    |                                       |   |                       |                       |      |       |
| V <sub>TOUT</sub>                                | Drive output high level               | R <sub>L</sub> =3kΩ to GND2   | 5                     | 6.5                   |      | V     |
|  | Drive output low level                | R <sub>L</sub> =3kΩ to GND2   |                       | -6.5                  | -5   | V     |
| R <sub>TOUT</sub>                                | Driver output impedance               |   | 300                   |                       |      | Ω     |
| I <sub>isc</sub>                                 | Driver short circuit current          |   |                       |                       | 60   | mA    |
| R <sub>TXD</sub>                                 | Internal TXD Pull up Resistor         |   |                       | 5.1                   |      | kΩ    |
| <b>Receiver</b>                                  |                                       |   |                       |                       |      |       |
| V <sub>RIN</sub>                                 | Receiver input range                  |   | -25                   |                       | 25   | V     |
| V <sub>RIL</sub>                                 | Receiver input low threshold voltage  |   | 0.6                   | 0.9                   |      | V     |
| V <sub>RIH</sub>                                 | Receiver input high threshold voltage |   |                       | 1.5                   | 2.4  | V     |
|  | Receiver input hysteresis             |   |                       | 0.4                   |      | V     |
| R <sub>RIN</sub>                                 | Receiver input impedance              |   | 3                     | 5                     | 7    | kΩ    |
| V <sub>ROH</sub>                                 | RXD high level output voltage         |   | V <sub>cc</sub> - 0.4 | V <sub>cc</sub> - 0.1 |      | V     |
| V <sub>ROL</sub>                                 | RXD low level output voltage          |   |                       |                       | 0.4  | V     |
| <b>Power supply and safeguard characteristic</b> |                                       |   |                       |                       |      |       |
| I <sub>cc</sub>                                  | Supply current                        |   |                       | 15                    | 30   | mA    |
| I <sub>cc</sub>                                  | Working current                       | No load   |                       | 20                    | 45   | mA    |
|  |                                       | R <sub>L</sub> =3kΩ to GND2   |                       | 20                    | 45   | mA    |
| ESD  | HBM                                   | TOUT、RIN to GND2  |                       |                       | ±15  | kV    |
|  |                                       | Other pin   |                       |                       | ±2   | kV    |
|  | Contact                               | TOUT、RIN to GND2  |                       |                       | ±8   | kV    |
| EFT  | IEC61000-4-4                          | TOUT、RIN to GND2  |                       |                       | ±2   | kV    |
| SURGE  | IEC61000-4-5                          | TOUT、RIN to GND2  |                       |                       | ±2   | kV    |
| VI-O   | Insulate voltage                      |   |                       |                       | 5000 | VDC   |
|  | Insulate impedance                    |   | 1                     |                       |      | GΩ    |
|  | Insulate capacitance                  |   |                       | 50                    |      | pF    |
| CMTI   | Common mode transient immunity        | TXD = V <sub>cc</sub> or 0 V, V <sub>CM</sub> = 1 kV, transient magnitude = 800 V | 25                    |                       |      | kV/us |

Note : ESD indicators are non-charged test specifications, GND2 need to be connected to the earth during testing.

## Transmission Characteristics

| Symbol                              | Parameter                  | Conditions  | Min. | Typ. | Max. | Unit |
|-------------------------------------|----------------------------|---|------|------|------|------|
| -                                   | Maximum data rate          | Duty 40% ~ 60%                                      |      |      | 120  | kbps |
| T <sub>PHL</sub> , T <sub>PLH</sub> | Driver propagation delay   | R <sub>L</sub> = 3kΩ to 7kΩ , C <sub>L</sub> = 50pF |      |      | 2    | us   |
| T <sub>PHL</sub> , T <sub>PLH</sub> | Receiver propagation delay | C <sub>L</sub> = 15pF                               |      |      | 2    | us   |

## Physical Specifications

| Parameters | Value      | Unit |
|------------|------------|------|
| Weight     | 0.9(Typ. ) | g    |

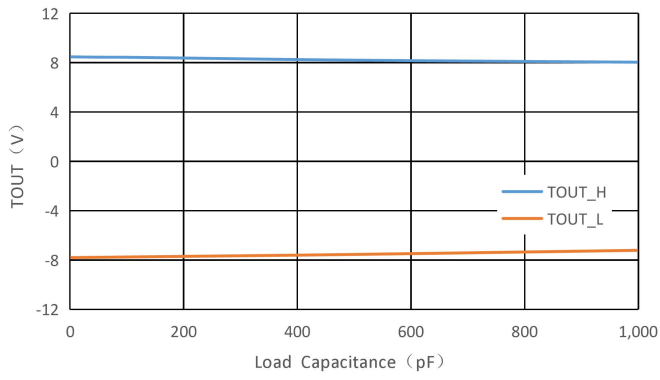

Figure 1. Transmitter Output Voltage High/Low VS Load Capacitance (120 kbps)

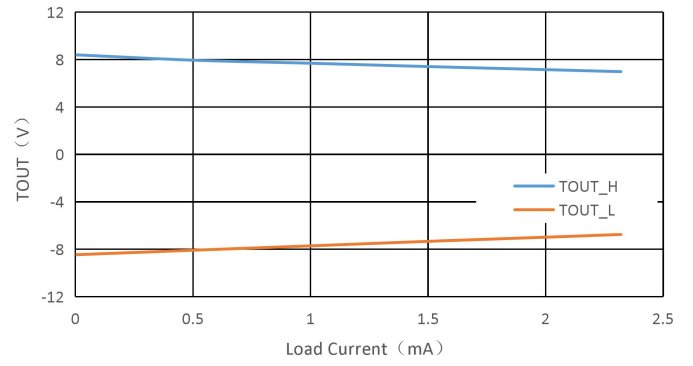

Figure 2. Transmitter Output Voltage High/Low VS Load Current

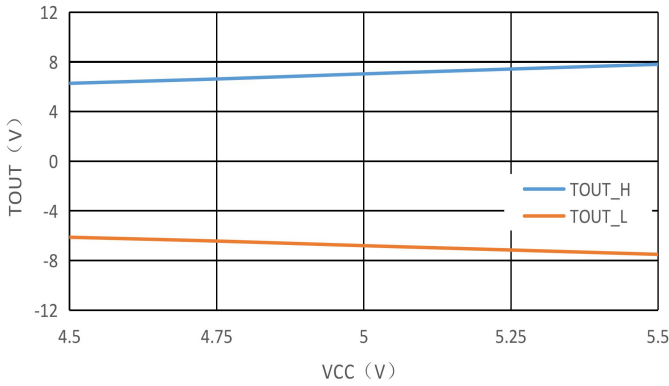

Figure 3. Transmitter Output Voltage High/Low VS VCC ( $R_L=3\text{ k}\Omega$ )

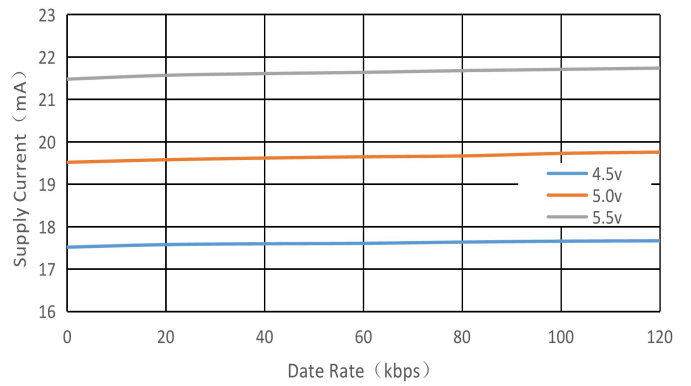

Figure 4. Supply current VS Data rate

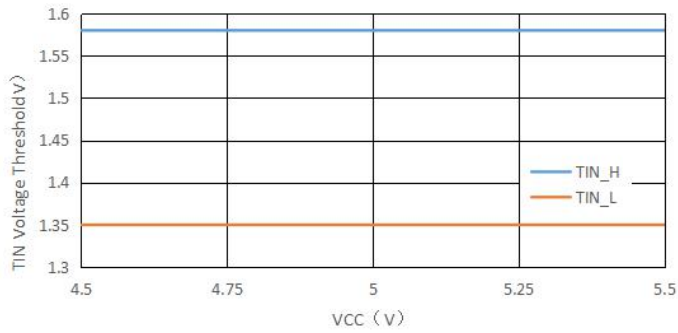

Figure 5. TIN Voltage Threshold VS VCC

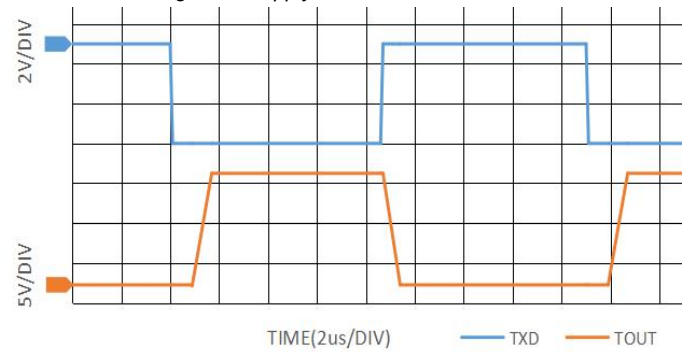

Figure 6. 120kbps Data Transmission ( $V_{CC}=5V, R_L=3\text{ k}\Omega$ )

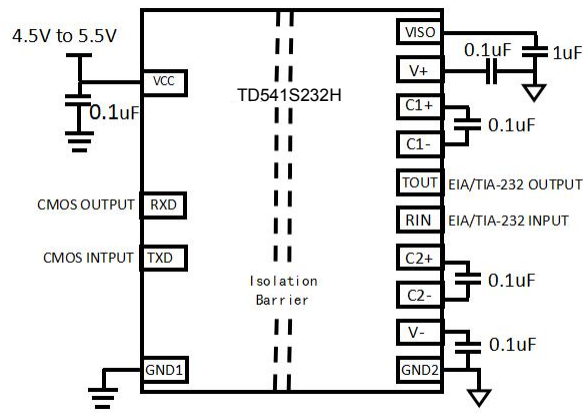

Figure7. The typical model applies telephone

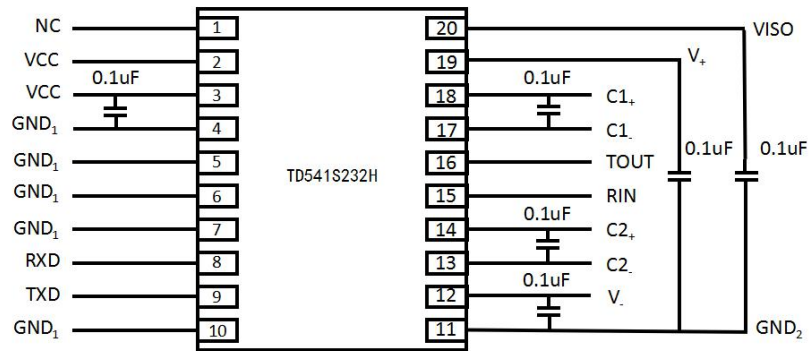

Figure8. Type PCB layout

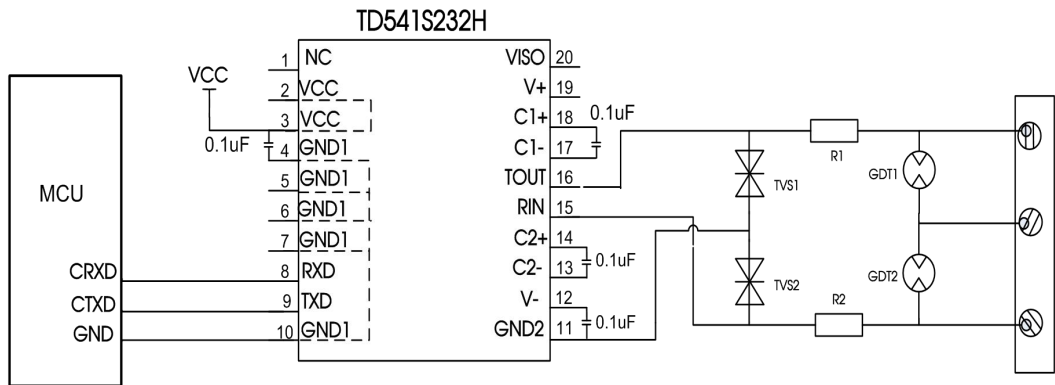

Figure9. Port protection circuit for harsh environments

Recommended components and values:

|            |                             |
|------------|-----------------------------|
| Components | TD541S232H                  |
| TVS1, TVS2 | SMCJ15CA                    |
| R1, R2     | 12Ω/2W(Wire-wound resistor) |
| GDT1, GDT2 | S30-A90X                    |

When the module is used in applications with harsh environment, it can be susceptible to large energy like lightning strike, etc. in which case, it is essential to add an adequate protection circuit to the 232 signal ports to protect the system from failure and maintain a reliable bus communication. Figure 9 provides a recommended protection circuit design for high-energy lightning surges, with a degree of protection related to the selected protection device. Parameter description lists a set of recommended circuit parameters, which can be adjusted according to the actual application situation. Also, when using the shielded cable, the reliable single-point grounding of the shield must be achieved.

Note: The recommended components and values is a general guideline only and must be verified for the actual user's application.

## Recommendations

- ① The power supply is not recommended for other purposes, otherwise it may cause the bus voltage did not meet the requirements of communication, causes the communication failure.
- ② Hot-swap is not supported.
- ③ The output of TD541S232H to RXD is only compatible with 5V system, if the I/O port is 3.3V level and does not support 5V input, please refer to the following recommended circuit :

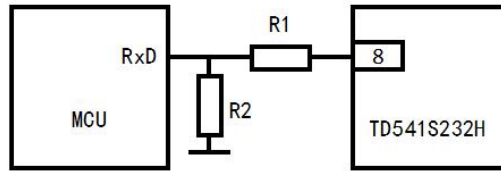

Figure10. Match MCU system connection

The calculation formula of resistance partial voltage of conventional step-down-circuit is

$$R1 = \frac{V_{out} - V_{in}}{V_{in}} R2$$

Where R1,R2 is piezoelectric resistance value of the connected part, Vout is TD541S232H output voltage, Vin is MCU RXD input voltage. The commend value is R1=1kΩ, R2=2kΩ.

④ If the external input of TXD is insufficient, the pull-up resistor should be added according to the situation.

⑤ Refer to IPC 7093 for the welding process design of this product. For detailed operation guidance, please refer to *Hot Air Gun Welding Operation Instruction for DFN Package Product* or *Welding Operation Instruction for DFN Package Product*.

## Ordering Information

| Part number | Package | Number of pins | Product marking | Tape & Reel |
|-------------|---------|----------------|-----------------|-------------|
| TD541S232H  | DFN     | 20             | TD541S232H      | 300/REEL    |

## Package Information

THIRD ANGLE PROJECTION

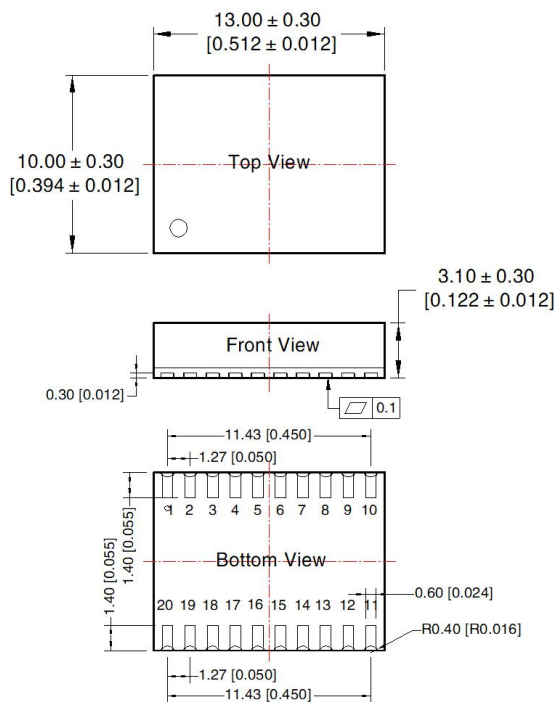

Note:  
Unit: mm[inch]  
General tolerances: ± 0.10[± 0.004]

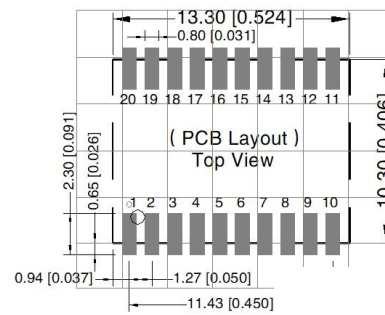

| Pin-Out |      |     |      |
|---------|------|-----|------|
| Pin     | Mark | Pin | Mark |
| 1       | NC   | 11  | GND2 |
| 2       | VCC  | 12  | V-   |
| 3       | VCC  | 13  | C2-  |
| 4       | GND1 | 14  | C2+  |
| 5       | GND1 | 15  | RIN  |
| 6       | GND1 | 16  | TOUT |
| 7       | GND1 | 17  | C1-  |
| 8       | RXD  | 18  | C1+  |
| 9       | TXD  | 19  | V+   |
| 10      | GND1 | 20  | VISO |

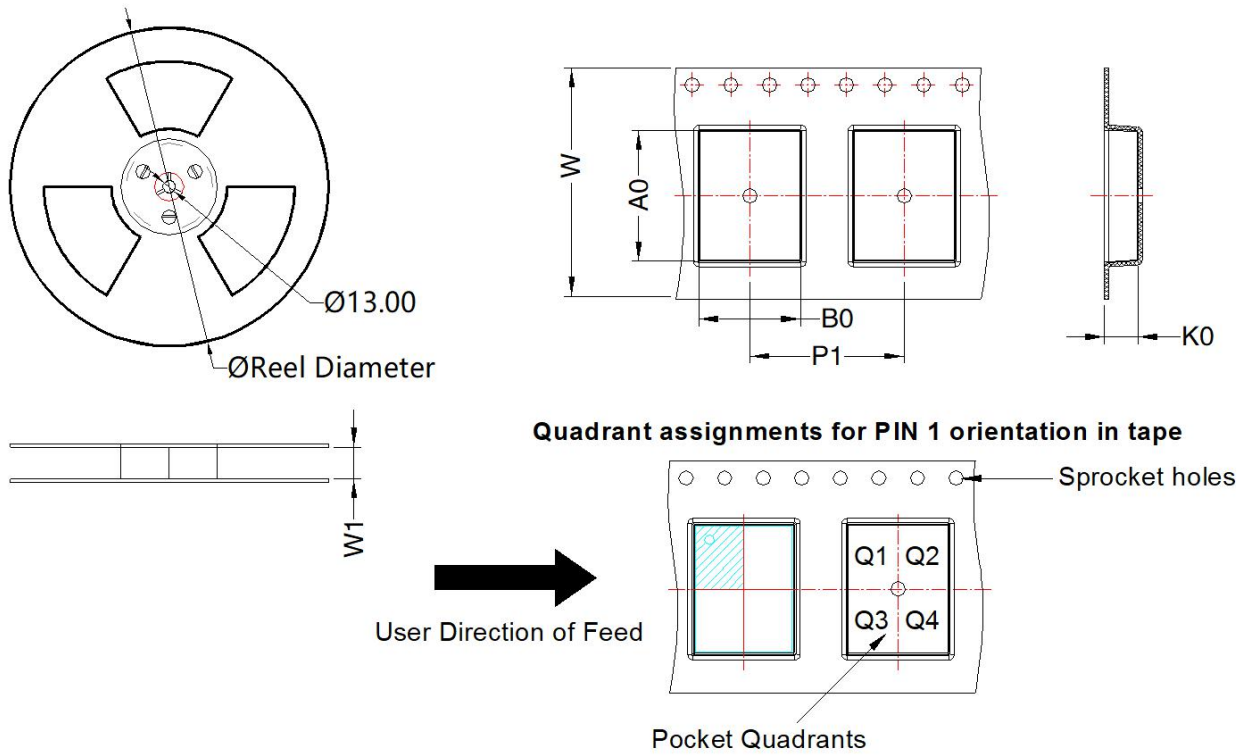

| Device     | Package Type | Pin | MPQ  | Reel Diameter (mm) | Reel Width W1 (mm) | A0 (mm) | B0 (mm) | K0 (mm) | P1 (mm) | W (mm) | Pin1 Quadrant |
|------------|--------------|-----|------|--------------------|--------------------|---------|---------|---------|---------|--------|---------------|
| TD541S232H | DFN 10x13    | 20  | 1000 | 330.0              | 24.4               | 13.52   | 10.52   | 3.5     | 16.0    | 24.0   | Q1            |

## MORNSUN Guangzhou Science & Technology Co., Ltd.

Address: No. 8 Nanyun 4th Road, Huangpu District, Guangzhou, China

Tel: 86-20-38601850

Fax: 86-20-38601272

E-mail: [info@mornsun.cn](mailto:info@mornsun.cn)

[www.mornsun-power.com](http://www.mornsun-power.com)