

TD341S485S-F1 DFN package isolated RS485 Transceiver

Features

- Ultra-small, ultra-thin, chip scale DFN package
- Compliant with TIA/EIA-485-A standard
- Integrated isolated 3.3V power
- I/O power supply range supports 3.3V and 5V microprocessors(Specific application refer to “ Recommendations ②”)
- High isolation to 5000VDC
- Bus-Pin ESD protection up to 15kV(HBM)
- Baud rate up to 20Mbps
- >25kV/us CMTI
- Low communication delay
- Full-duplex
- 1/8 unit load, up to 256 nodes on a bus
- Bus fail-safe
- Bus driver short circuit protection
- Industrial operating ambient temperature range: -40°C to +105°C
- Moisture Sensitivity Level (MSL) 3

Package

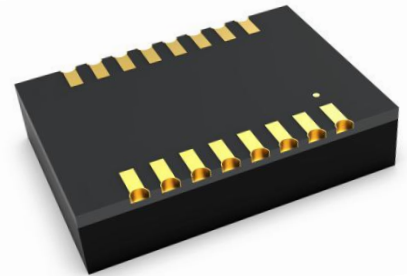

Applications

- Industrial Automation
- Building Automation
- Smart Electricity Meter
- Remote Signal Interaction, Transmission

Functional Description

TD341S485S-F1 is a full-duplex enhanced transceiver designed for RS-485 data bus networks, which is fully compliant with TIA/EIA-485-A standard and is suitable for data transmission of up to 20 Mbps. Their logic side supports 3.3V and 5V logic level conversion. Receivers have an exceptionally high input impedance, which places only 1/8 of the standard load on a shared bus and up to 256 transceivers.

The reliability design of A, B, Z, Y pin is emphasized, including driver output over current protection and enhanced ESD design. The ESD protection level of A, B, Z, Y pin can be up to 15kV (Human Body Model).

Contents

| | | | | | |
|-----|---------------------------------------|---|-----|--|----|
| 1 | Home..... | 1 | 4 | Characteristic Curve..... | 5 |
| 1.1 | Feature and Package..... | 1 | 4.1 | Typical Performance Curve..... | 5 |
| 1.2 | Applications..... | 1 | 4.2 | Parameter Measurement Information..... | 6 |
| 1.3 | Functional Description..... | 1 | 5 | Product working Description..... | 6 |
| 2 | Pin Connection and Description..... | 2 | 6 | Application Circuit..... | 7 |
| 3 | IC Related Parameters..... | 3 | 7 | Suggestions for Power Supply..... | 8 |
| 3.1 | Absolute Maximum Rating..... | 3 | 8 | After-sales Service..... | 8 |
| 3.2 | Recommended Operating Conditions..... | 3 | 9 | Order Information..... | 8 |
| 3.3 | Electrical Characteristics..... | 4 | 10 | Package Information..... | 9 |
| 3.4 | Transmission Characteristics..... | 5 | 11 | Tape & Reel Information..... | 10 |
| 3.5 | Physical Information..... | 5 | | | |

Pin Connection

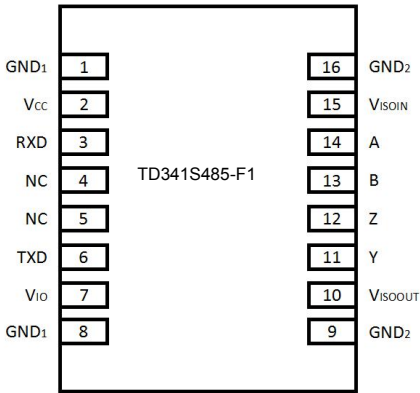

Note: All GND₁ pins are internally connected.
All GND₂ pins are internally connected.

Internal Block

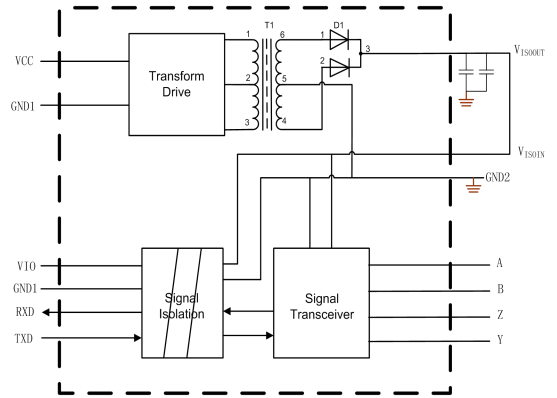

Function Table

| Letter | Description |
|--------|----------------|
| H | High-Level |
| L | Low-Level |
| X | Unrelated |
| Z | High Impedance |

Table 1. Driver Function table

| TXD | Output | |
|------|--------|---|
| | Y | Z |
| H | H | L |
| L | L | H |
| OPEN | H | L |

Table 2. Receiver Function table

| Difference input $V_{ID} = (V_A - V_B)$ | RXD |
|--|-------------|
| $-0.01 V \leq V_{ID}$ | H |
| $-0.2 V < V_{ID} < -0.01 V$ | Uncertainty |
| $V_{ID} \leq -0.2 V$ | L |
| Open circuit | H |
| Short circuit | H |

Pin Descriptions

| Pin Number | Pin Name | Pin Functions |
|------------|---------------------|---|
| 1 | GND ₁ | Ground (Logic side). |
| 2 | V _{CC} | Power supply. By using 0.1uF ceramic capacitance ground(GND ₁). |
| 3 | RXD | Receiver output pin. |
| 4 | NC | Not connected. |
| 5 | NC | Not connected. |
| 6 | TXD | Driver input pin. |
| 7 | V _{IO} | Power supply of Logic side. By using 1uF ceramic capacitance ground(GND ₁). |
| 8 | GND ₁ | Ground(Logic side). |
| 9 | GND ₂ | Ground (Bus Side). |
| 10 | V _{ISOOUT} | Insulation power output. By using 1uF Ceramic capacitance ground(GND ₂ , pin9). The pin needs to be connected to pin15 in application. |
| 11 | Y | Driver Noninverting Output. |
| 12 | Z | Driver inverting Output. |
| 13 | B | Receiver Inverting Input. |
| 14 | A | Receiver Noninverting Input. |
| 15 | V _{ISOIN} | Insulation power input. By using 0.1uF ceramic capacitance ground(GND ₂ , pin16). The pin needs to be connected to pin10 in application. |
| 16 | GND ₂ | Ground (Bus Side). |

Absolute Maximum Ratings

General test conditions: Free-air, normal operating temperature range (Unless otherwise specified).

| Parameters | Unit |
|------------------------------------|--|
| Supply voltage (V _{CC}) | -0.3V to +3.5V |
| V _{IO} Input Voltag | -0.3V to+6V |
| A, B Z, Y Bus voltage | -8V to+13V |
| Digital Input Voltage (TXD, RXD) | -0.3V to+6V |
| Operating Temperature Range | -40°C to +105°C |
| Storage Temperature Range | -50°C to +125°C |
| Reflow Soldering Temperature | Peak temp. ≤250°C, maximum duration ≤60s at 217°C. Please also refer to IPC/JEDEC J-STD-020D. 3. |

Important: Exposure to absolute maximum rated conditions for an extended period may severely affect the device reliability, and stress levels exceeding the "Absolute Maximum Ratings" may result in permanent damage.

Recommended Operating Conditions

| Symbol | Recommended Operating Conditions | Min. | Typ. | Max. | Unit |
|-----------------|---|----------|------|-----------------|------|
| V _{CC} | Supply voltage | 3.15 | 3.3 | 3.45 | V |
| V _{IO} | Supply voltage | 2.375 | 3.3 | 5.5 | |
| V _I | Voltage at any bus terminal (differential or common mode) | -7 | | 12 | |
| V _{IH} | High-level input voltage(TXD) | 2 | | V _{IO} | |
| V _{IL} | Low-level input voltage(TXD) | 0 | | 0.8 | |
| I _{OS} | Output current | | | | mA |
| | | Driver | -60 | 60 | |
| | | Receiver | -8 | 8 | |
| R _{IN} | Differential output load resistance | 54 | 60 | | Ω |
| T _A | Operating temperature range | -40 | | 105 | °C |
| - | Signaling rate | | | 20 | Mbps |

| Symbol | Parameter | Conditions | Min. | Typ. | Max. | Unit | |
|--|---|---|------------------------|-----------------------|------|-------|----|
| Driver | | | | | | | |
| V _{OD} | Differential driver output | No load | 3.0 | | | V | |
| | | R _L = 54Ω, Figure 7 | 1.5 | 2.0 | | V | |
| | | R _L = 100Ω, Figure 7 | 2.0 | | | V | |
| ΔV _{OD} | Δ V _{OD} for complementary output states | R _L = 54Ω, Figure 7 | | | ±0.2 | V | |
| V _{OC} | Common-Mode output voltage | Figure 6 | 1 | | 3 | V | |
| ΔV _{OC(SS)} | Δ V _{OC} for complementary output states | Figure 6 | -0.1 | | 0.1 | V | |
| I _{OS} | Output short-circuit current | -7V ≤ V _A or V _B ≤ 12V | | ±110 | ±250 | mA | |
| Receiver | | | | | | | |
| V _{IT(+)} | Positive differential input threshold voltage | -7 V ≤ V _A or V _B ≤ +12 V | | | -10 | mV | |
| V _{IT(-)} | Negative differential input threshold voltage | -7 V ≤ V _A or V _B ≤ +12 V | -200 | | | mV | |
| V _{hys} | Hysteresis voltage (V _{IT+} - V _{IT-}) | -7 V ≤ V _A or V _B ≤ +12 V | | 20 | | mV | |
| R _{ID} | Differential input resistance(A, B) | -7 V ≤ V _A or V _B ≤ +12 V | 96 | | | kΩ | |
| I _I | Input current (A, B) | V _{CC} = 0 or 3.3V | V _{OUT} = 12V | | 190 | 250 | uA |
| | | | V _{OUT} = -7V | -200 | -110 | | uA |
| V _{OH} | RXD output high voltage | I _{OUT} = 20 μA, V _A - V _B = 0.2 V | V _{IO} - 0.1 | | | V | |
| | | I _{OUT} = 4 mA, V _A - V _B = 0.2 V | V _{IO} - 0.4 | V _{IO} - 0.2 | | V | |
| V _{OL} | RXD output low voltage | I _{OUT} = -20 μA, V _A - V _B = -0.2 V | | | 0.1 | V | |
| | | I _{OUT} = -4 mA, V _A - V _B = -0.2 V | | | 0.4 | V | |
| Power supply and safeguard characteristic | | | | | | | |
| I _{CC} | Supply current | | | 18 | 40 | mA | |
| I _{CC} | Working current | Between Y, Z 100Ω load | | 95 | 125 | mA | |
| | | Between Y, Z 54Ω load | | 105 | 135 | mA | |
| ESD | HBM | A, B, Y, Z to GND | | | ±15 | kV | |
| | | Other pin | | | ±2 | kV | |
| EFT | IEC61000-4-4 | A, B, Y, Z and GND | | | ±2 | kV | |
| SURGE | IEC61000-4-5 | A, B, Y, Z and GND(Common Mode) | | | ±2 | kV | |
| VI-O | Insulate voltage | | | | 5000 | VDC | |
| | Insulate impedance | | 1 | | | GΩ | |
| | Insulate capacitance | | | 3 | | pF | |
| CMTI | Common mode transient immunity | TXD = V _{CC} or 0 V, V _{CM} = 1 kV, transient magnitude = 800 V | 25 | | | kV/us | |

Transmission Characteristics

| Symbol | Parameter | Conditions | Min. | Typ. | Max. | Unit |
|---------------------|---|---|-----------------------|------|------|------|
| - | Maximum data rate | Duty 40% ~ 60% | | | 20 | Mbps |
| T_{PHL}, T_{PLH} | Driver propagation delay | $R_L = 54\Omega, C_L = 50pF$, Figure 8 | | 25 | 90 | ns |
| $ T_{PHL}-T_{PLH} $ | Driver skew ($ T_{PHL} - T_{PLH} $) | | | | 15 | ns |
| T_R, T_F | Driver rise/fall time | | | | 60 | ns |
| T_{PHL}, T_{PLH} | Receiver propagation delay | $C_L = 15pF$ Figure 9 | | 60 | 150 | ns |
| $ T_{PHL}-T_{PLH} $ | Receiver skew ($ T_{PLH} - T_{PHL} $) | | | 10 | 20 | ns |
| T_R, T_F | Receiver rise/fall time | | $C_L = 15pF$ Figure 9 | | 25 | |

Physical Specifications

| Parameters | Value | Unit |
|------------|------------|------|
| Weight | 1.0(Typ.) | g |

Typical Performance Curves

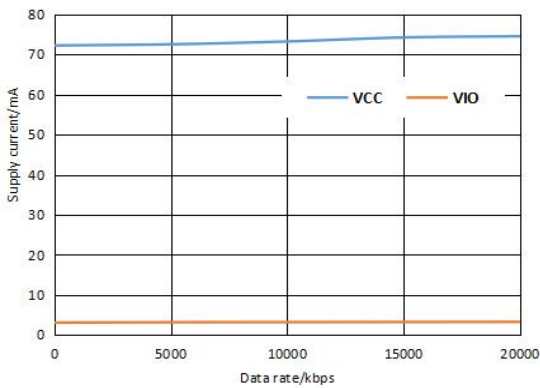

Figure 1. Supply current vs. Data rate

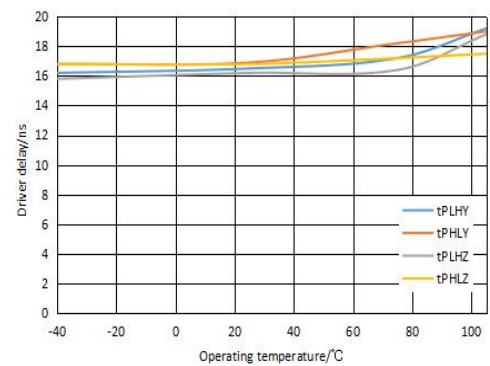

Figure 2. Driver delay vs. Operating temperature

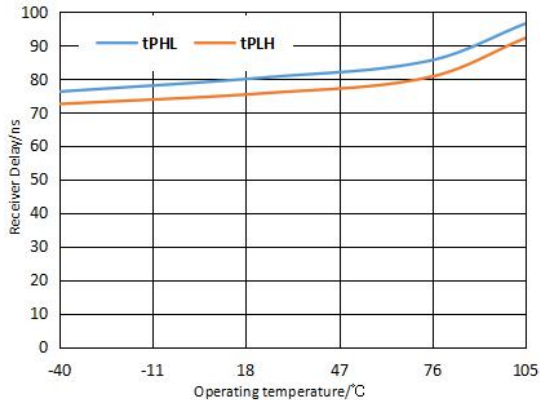

Figure 3. Receiver delay vs. Operating temperature

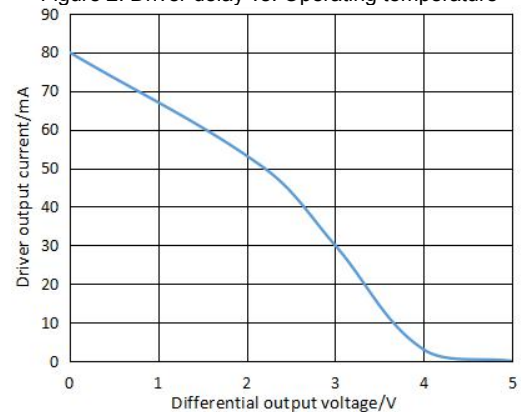

Figure 4. Driver output current vs. Differential output voltage

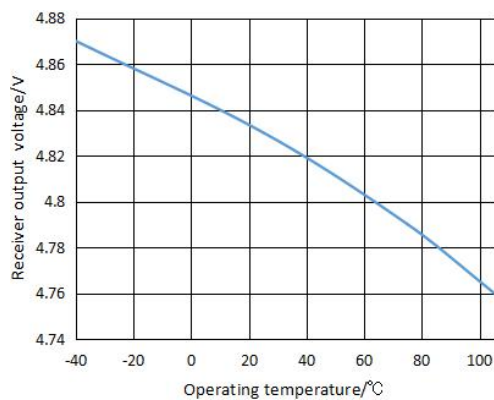

Figure 5. Receiver output high voltage vs. Operating temperature

Test Circuits

Note: The load capacitance of the test conditions includes the parasitic capacitance of the test probe and the test fixture (no special instructions). The rising and falling edges of the test signal are less than 6ns, the frequency is 100kHz, and the duty cycle is 50%. Impedance matching $Z_0 = 54\Omega$ (no special instructions).

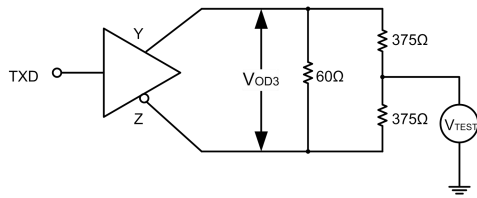

Fig 6. Common Mode Output Test Circuit

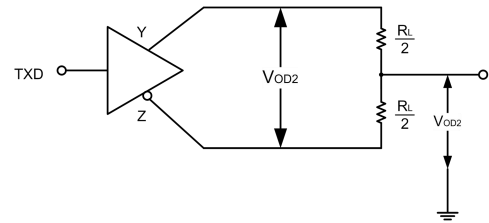

Fig 7. Differential output test circuit

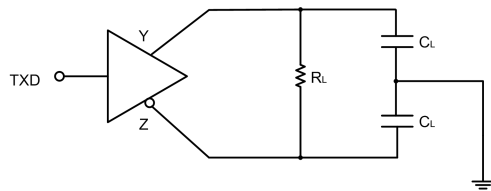

Fig 8. Send Delay Test Circuit

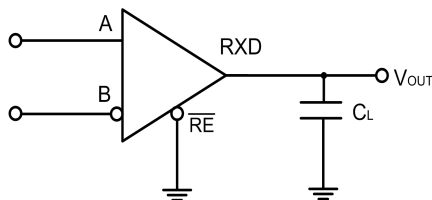
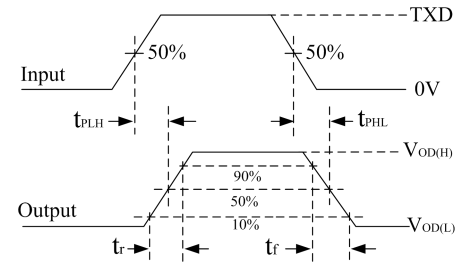
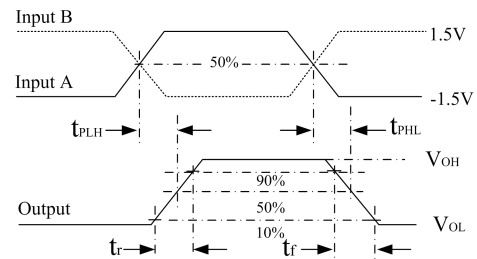

Fig 9. Receive delay test circuit



Detailed Description

TD341S485S-F1 is a full-duplex enhanced RS485 isolated transceiver with isolated power supply. In addition to an isolated power supply, each transceiver contains a drive and a receiver. The transceiver has a standby bus failure protection function to ensure that the receiver output is high when the receiver input is open, short, or when the bus is idle. TD341S485S-F1 adopts 3.3VDC power supply. The whole machine can monitor the overall working state of the module and limit the output high current, so as to prevent the bus overload or short circuit from causing non-recoverable damage to the transceiver.

Receiver input filter: TD341S485S-F1 receiver integrated high performance input filter, the filter can greatly enhance the receiver's noise suppression ability to high speed differential signal. Therefore, the transmission delay of the receiver is also caused by this reason.

Bus failure protection: In general, when $-200\text{mV} < A - B < -10\text{mV}$, the bus receiver will be in an uncertainty state. This phenomenon occurs when the bus is idle. Bus failure protection ensures that the receiver outputs a high level when the receiver input is open, short, or when the bus access port matches the resistance. TD341S485S-F1 receiver threshold voltage is relatively accurate, and the threshold voltage to the reference ground has a margin of at least 10mV, which can ensure that even if the bus differential voltage is 0V, the receiver output level is high, and meets the requirements of EIA/TIA-485 standard $\pm 200\text{mV}$.

The bus load capacity (256 point): standard RS485 receiver input impedance is defined as 12 k Ω (unit load). A standard RS485 driver can drive at least 32 load units. TD341S485S-F1 bus receiver designed by 1/8 unit load, the input impedance is greater than 96 k Ω . As a result, the bus allows access to more transceivers (up to 256). TD341S485S-F1 can also be mixed with the standard RS485 transceiver with 32 unit loads (cumulative receiver load cannot exceed 32 units).

Drive output protection: TD341S485S-F1 internal integrated drive short circuit (or overcurrent) protection module. In case of bus error or driver short circuit, the module can limit the output current of the driver within a certain limit.

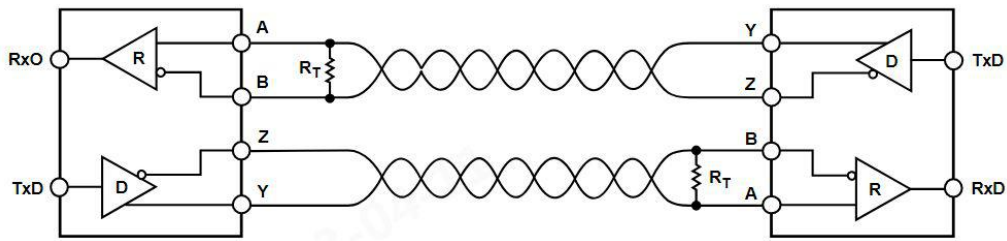

Fig 10. Typical Application Circuit (Full-Duplex Network Topology)

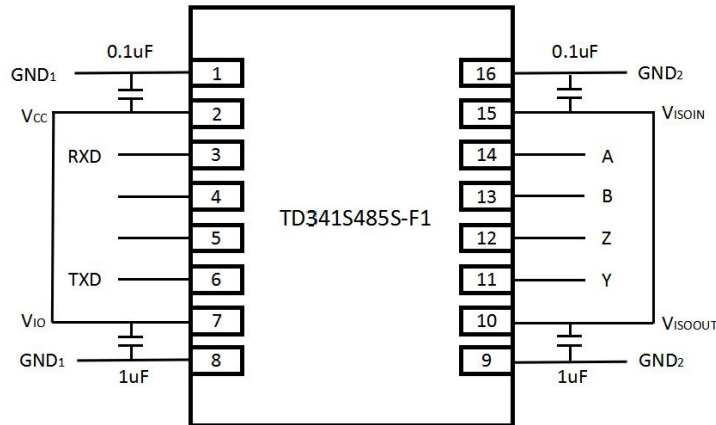

Fig 11. Typical Application of PCB layout

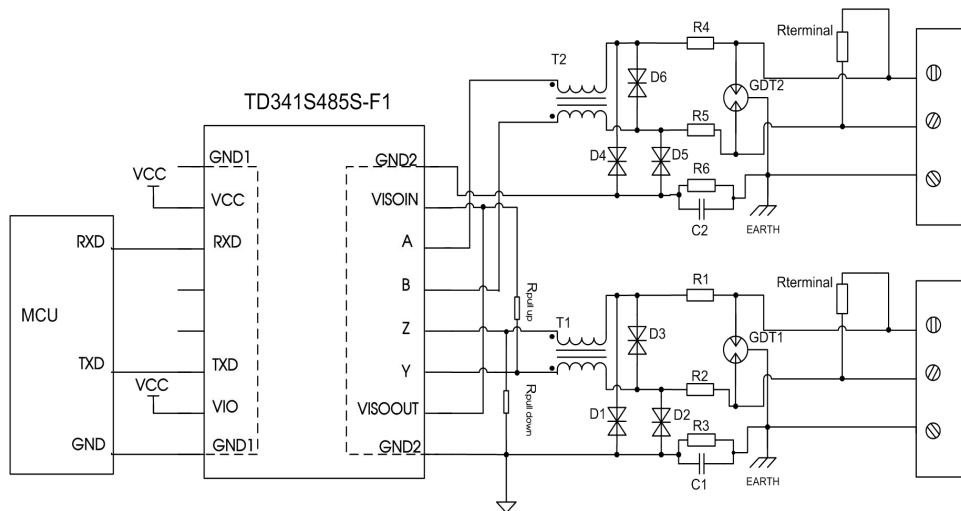

Fig 12. Port Protection Recommended Circuit

Recommended components and values:

| Component | Recommended part, value | Component | Recommended part, value |
|-----------|-------------------------|-------------|-------------------------|
| R3,R6 | 1MΩ | R1,R2,R4,R5 | 2.7Ω/2W |
| C1,C2 | 1nF, 2kV | D1,D2,D4,D5 | SMBJ6.5CA |
| T1,T2 | ACM2520-301-2P | D3,D6 | SMBJ6.5CA |
| GDT1,GDT2 | B3D090L | Rterminal | 120 Ω |

As the modules internal A / B / Z / Y lines come with its own ESD protection, which generally satisfy most application environments without the need for additional ESD protection devices. For harsh and noisy application environments such as motors, high voltage/current switches, lightning and similar however, we recommended that the user protects the module's A / B / Z / Y lines with additional measures and external components such as TVS tube, common mode inductors, Gas discharge tube, shielded twisted pair of wires with the same single network Earth point. Figure 13 shows our recommended circuit diagram for such type of applications with components and values given in the table above. This recommendation is for reference only and may have to be adapted accordingly with appropriate component values in order to match the actual situation and application.

Note 1: Select the $R_{terminal}$ according to the actual application.

Note 2: When using the port protection circuit, you need to slow down the baud rate.

Recommendations

- ① Power isolation V_{ISOOUT} need through a series of capacitors connected to the output pin V_{ISOIN} , in addition to the mentioned in article 5 of the pull up and down function, the power supply is not recommended for other purposes, otherwise it may cause the bus voltage did not meet the requirements of communication, causes the communication failure.
- ② V_{IO} pin decide the output level of RXD pin. Normally, V_{IO} pin need to connected to the V_{CC} pin to support 3.3V microprocessors. V_{IO} pin need to disconnect to the V_{CC} pin and need a 5V power supply separately to support 5V microprocessors if necessary.
- ③ TXD contains a 10k Ω pull up resistor .
- ④ TXD pin is always not allow to set to open drain output state connect the controller, otherwise it will lead to uncertain consequences.
- ⑤ To maintain bus idle stability, we need at least one node will pull up Y to V_{ISOIN} and drop down Z to GND_2 on the bus. Overall network at the same time pull up and drop down resistors of the parallel value must around 380 Ω to 420 Ω (0.2W).

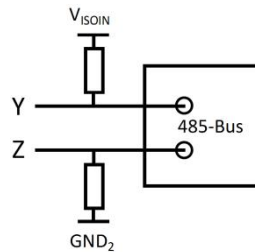

Fig 13. Typical connection of pull-up and pull-down resistors

- ⑥ Hot-swap is not supported.
- ⑦ If the external input of TXD is insufficient, the pull-up resistor should be added according to the situation.
- ⑧ Refer to *IPC 7093* for the welding process design of this product. For detailed operation guidance, please refer to *Hot Air Gun Welding Operation Instruction for DFN Package Product* or *Welding Operation Instruction for DFN Package Product*.

After-sales Service

1. Factory inspection and quality control are strictly enforced before shipping any product; please contact your local representative or our technical support if you experience any abnormal operation or possible failure of the module;
2. The products have a 3-year warranty period, from the date of shipment. The product will be repaired or exchanged free of charge within the warranty period for any quality problem that occurs under normal use.

Ordering Information

| Part number | Package | Number of pins | Product marking | Tape & Reel |
|---------------|---------|----------------|-----------------|-------------|
| TD341S485S-F1 | DFN | 16 | TD341S485S-F1 | 300/REEL |

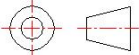
THIRD ANGLE PROJECTION 

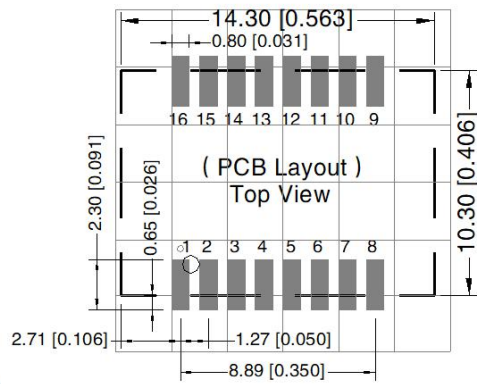
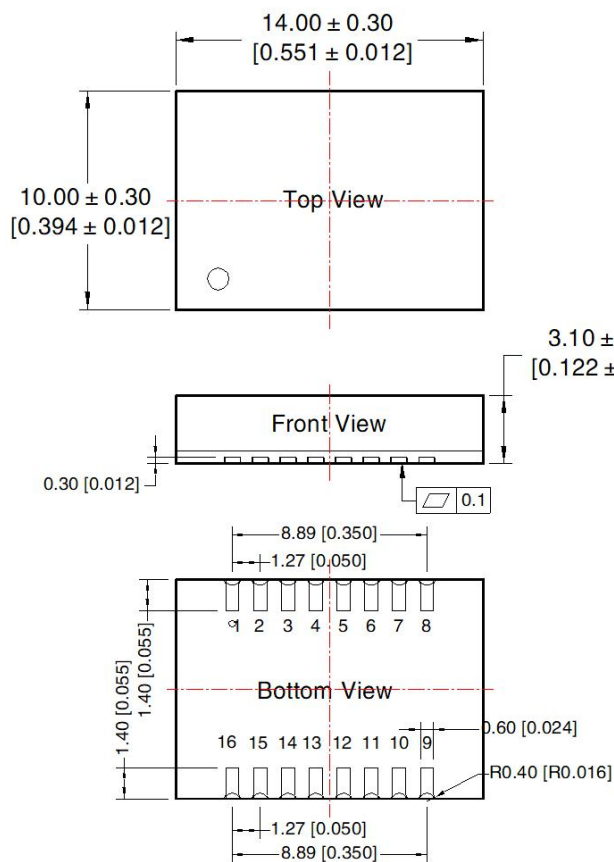

| Pin-Out | | | |
|---------|------------------|-----|---------------------|
| Pin | Mark | Pin | Mark |
| 1 | GND ₁ | 9 | GND ₂ |
| 2 | V _{CC} | 10 | V _{ISOOUT} |
| 3 | RXD | 11 | Y |
| 4 | NC | 12 | Z |
| 5 | NC | 13 | B |
| 6 | TXD | 14 | A |
| 7 | V _{IO} | 15 | V _{ISOIN} |
| 8 | GND ₁ | 16 | GND ₂ |

Note:
 Unit: mm[inch]
 General tolerances: ± 0.10 [± 0.004]

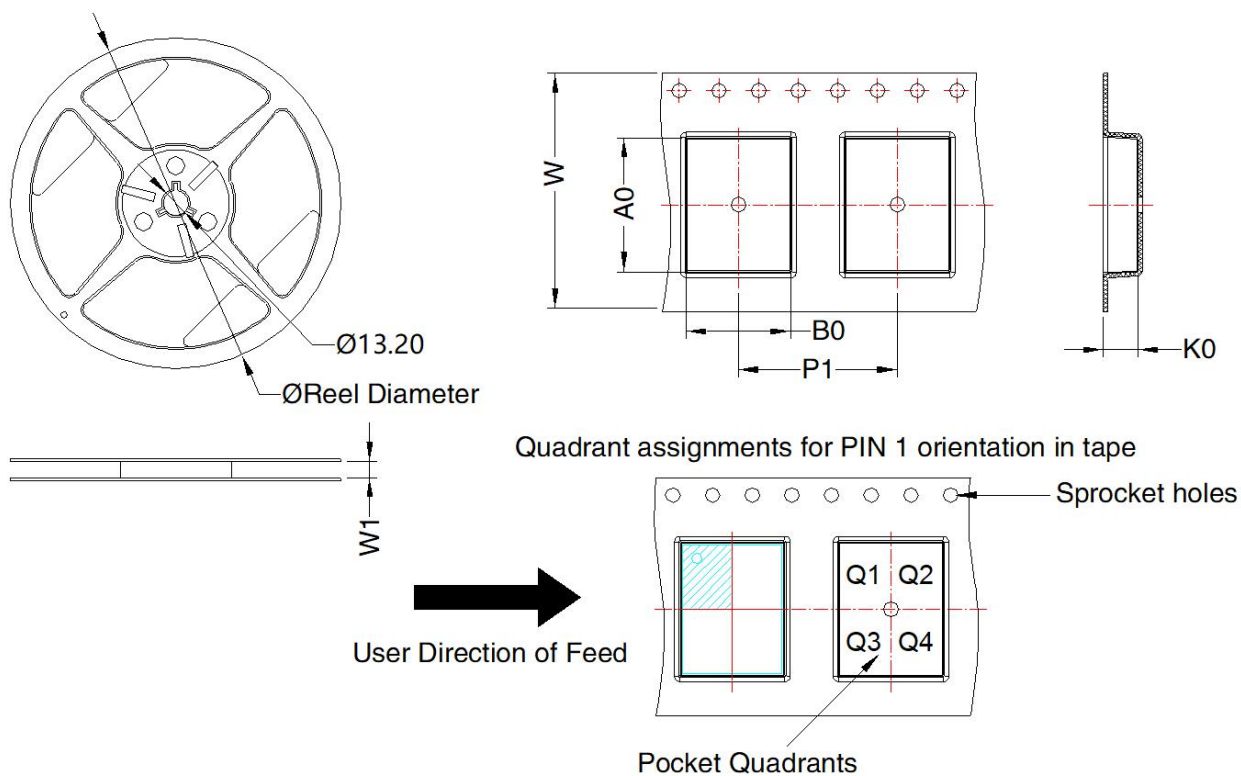

| Device | Package Type | Pin | MPQ | Reel Diameter (mm) | Reel Width W1 (mm) | A0 (mm) | B0 (mm) | K0 (mm) | P1 (mm) | W (mm) | Pin1 Quadrant |
|---------------|--------------|-----|-----|--------------------|--------------------|---------|---------|---------|---------|--------|---------------|
| TD341S485S-F1 | DFN 10x14 | 16 | 300 | 180.0 | 24.4 | 14.52 | 10.52 | 3.5 | 16.0 | 24.0 | Q1 |

MORNSUN Guangzhou Science & Technology Co., Ltd.

Address: No. 8 Nanyun 4th Road, Huangpu District, Guangzhou, China

Tel: 86-20-38601850

Fax: 86-20-38601272

E-mail: info@mornsun.cn

www.mornsun-power.com