

## TD041S485H-A DFN package isolated RS485 Transceiver

### Features

- Ultra-small, ultra-thin, chip scale DFN package
- Compliant with TIA/EIA-485A standard
- I/O power supply range supports 3.3V and 5V microprocessors
- High isolation to 3750Vrms
- Bus-Pin ESD protection up to 15kV(HBM)
- Communication rate is up to 500kbps
- > 25kV/μs CMTI
- Automatic send and receive data function
- 1/8 unit load—up to 256 nodes on a bus
- Bus fail-safe
- Bus driver short circuit protection
- Industrial operating ambient temperature range: -40°C to +105°C
- Moisture Sensitivity Level (MSL) 3

### Applications

- Industrial Automation
- Building Automation
- Smart Electricity Meter
- Remote Signal Interaction, Transmission

### Package

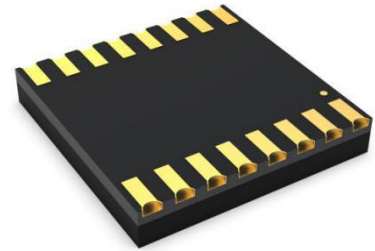

### Functional Description

TD041S485H-A is a half-duplex enhanced transceiver designed for RS-485 data bus networks, which is fully compliant with TIA/EIA-485A standard. In addition, the product features an automatic switching function, that no longer requires the need to pass through the node to send and receive control signals, which to a certain extent, reduces the design complexity. Their logic side supports 3.3V and 5V logic level conversion. Receivers have an exceptionally high input impedance, which places only 1/8 of the standard load on a shared bus and up to 256 transceivers.

TD041S485H-A reliability design of A, B pin is emphasized, including driver output over current protection and enhanced ESD design. The ESD protection level of A,B pin can be up to 15kV (Human Body Model).

## Contents

1 Home.....1	5 Characteristic Curve.....5
1.1 Feature and Package.....1	5.1 Typical Performance Curve.....5
1.2 Applications.....1	5.2 Parameter Measurement Information.....5
1.3 Functional Description.....1	6 Product Working Description.....7
2 Pin Package and internal block diagram.....2	7 Application Circuit.....7
3 Truth table.....2	8 Suggestions for Power Supply.....7
4 IC Related parameters.....3	9 Order Information.....8
4.1 Absolute Maximum Rating.....3	10 Package Information.....8
4.2 Recommended Operating Conditions.....3	11 Tape & Reel Information.....9
4.3 Electrical Characteristics.....4	
4.4 Transmission Characteristics.....4	
4.5 Physical Specifications.....5	

### Pin Connection

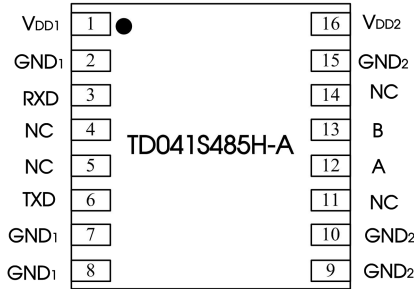

Note: All GND<sub>1</sub> pins are internally connected;  
All GND<sub>2</sub> pins are internally connected.

### Internal Block Diagram

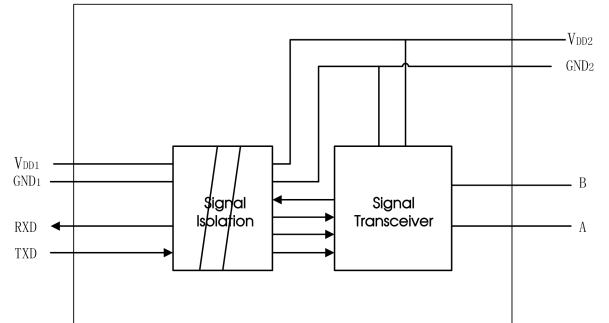

### Function Table

Letter	Description
H	High-Level
L	Low-Level
X	Unrelated
Z	High Impedance
NC	No Connection

Table 1. Driver Function Table

Power		Input	Output	
V <sub>DD1</sub>	V <sub>DD2</sub>	TXD	A	B
On	On	H	H	L
On	On	L	L	H

Table 2. Receiver Function Table

Power		Input	Output
V <sub>DD1</sub>	V <sub>DD2</sub>	A-B (V)	RXD
On	On	>-0.01	H
On	On	<-0.2	L
On	On	-0.2 < A - B < -0.01	Uncertainty
On	On	OPEN	H
Off	Off	X	L

## Pin Descriptions

Pin Number	Pin Name	Pin Functions
1	V <sub>DD1</sub>	Power Supply(Logic side)
2	GND <sub>1</sub>	Ground(Logic side)
3	RXD	Receiver Output Data
4	NC	No Connect
5	NC	No Connect
6	TXD	Driver Input
7	GND <sub>1</sub>	Ground(Logic side)
8	GND <sub>1</sub>	Ground(Logic side)
9	GND <sub>2</sub>	Ground (Bus Side)
10	GND <sub>2</sub>	Ground (Bus Side)
11	NC	No Connect
12	A	RS485 Bus A Line
13	B	RS485 Bus B Line
14	NC	No Connect
15	GND <sub>2</sub>	Ground (Bus Side)
16	V <sub>DD2</sub>	Power Supply (Bus Side)

## Absolute Maximum Ratings

General test conditions: Free-air, normal operating temperature range (unless otherwise specified).

PARAMETERS	UNIT
V <sub>DD1</sub>	-0.5 V to +7 V
V <sub>DD2</sub>	-0.5 V to +6 V
Digital Input Voltage (TXD)	-0.3V to +6V
Digital Output Voltage (RXD)	-0.3V to +6V
Driver Output / Receiver input Voltage	-8 V to +13 V
Operating Temperature Range	-40°C to +105°C
Storage Temperature Range	-50°C to +125°C
Reflow Soldering Temperature	Peak temp. ≤260°C, maximum duration ≤60s at 217°C. Please also refer to IPC/JEDEC J-STD-020D.3.

Important: Exposure to Absolute Maximum Rated conditions for an extended period may severely affect the device reliability, and stress levels exceeding the "Absolute Maximum Ratings" may result in permanent damage.All voltage values are referenced to the reference ground (GND).

## Recommended Operating Conditions

Recommended Operating Conditions		Min.	Typ.	Max.	Unit
V <sub>DD1</sub>	Logic Power Supply	2.375	3.3	5.5	V
V <sub>DD2</sub>	Bus Power Supply	4.5	5	5.5	
V <sub>IH</sub>	High-level input voltage(TXD)	2		V <sub>DD1</sub>	
V <sub>IL</sub>	Low-level input voltage(TXD)	0		0.8	
V <sub>ID</sub>	Differential input voltage	-7		+12	
	Signaling rate			500	kbps

## Electrical Characteristics

General test conditions and V<sub>DD1</sub>=V<sub>DD2</sub>= 5V, Ta = 25°C (unless otherwise specified).

PARAMETERS	CONDITIONS	Min.	Typ.	Max.	Unit
<b>DRIVER</b>					
V <sub>od</sub>	Differential Driver Output	R <sub>L</sub> = ∞, Figure 6	1.5		V
I <sub>os</sub>	Output Short-Circuit Current	-7V≤V <sub>A</sub> or V <sub>B</sub> ≤12V		±110	±250 mA

V <sub>IH</sub>	Input High Voltage	TXD	2			V
V <sub>IL</sub>	Input Low Voltage	TXD			0.8	V
<b>RECEIVER</b>						
V <sub>IT(+)</sub>	Positive Differential Input Threshold Voltage	-7 V ≤ V <sub>A</sub> or V <sub>B</sub> ≤ +12 V			-10	mV
V <sub>IT(-)</sub>	Negative Differential Input Threshold Voltage	-7 V ≤ V <sub>A</sub> or V <sub>B</sub> ≤ +12 V	-200			mV
V <sub>hys</sub>	Hysteresis Voltage (V <sub>IT+</sub> - V <sub>IT-</sub> )	-7 V ≤ V <sub>A</sub> or V <sub>B</sub> ≤ +12 V		20		mV
R <sub>ID</sub>	Differential Input Resistance(A,B)	-7 V ≤ V <sub>A</sub> or V <sub>B</sub> ≤ +12 V	96			kΩ
V <sub>OH</sub>	RXD Output High Voltage	I <sub>OUT</sub> = 4 mA, V <sub>A</sub> - V <sub>B</sub> = 0.2 V	V <sub>DD1</sub> - 0.4	V <sub>DD1</sub> - 0.2		V
V <sub>OL</sub>	RXD Output Low Voltage	I <sub>OUT</sub> = -4 mA, V <sub>A</sub> - V <sub>B</sub> = 0.2 V			0.4	V
<b>Supply and Protection</b>						
I <sub>DD1</sub>	Supply Current(Logic side)	No load			3	mA
I <sub>DD2</sub>	Supply Current(Bus side)	No load			13	mA
I <sub>DD</sub>	Max. Operating Current	No load			25	mA
ESD	HBM	A, B and GND			±15	kV
		Other pins			±2	kV
	Contact	A, B and GND			±4	kV
EFT	IEC61000-4-4 : Perf. Criteria B	A, B and GND			±2	kV
Surge	IEC61000-4-5 : Perf. Criteria B	A, B and GND(Common Mode)			±2	kV
V <sub>I-O</sub>	Isolation Test	Leakage current <1mA.			3750	Vrms
R <sub>I-O</sub>	Insulation Resistance	At 500VDC	1000			MΩ
C <sub>I-O</sub>	Isolation capacitor			3		pF
CMTI	Common Mode Transient Immunity	TXD = V <sub>DD1</sub> or 0 V, V <sub>CM</sub> = 1 kV, transient magnitude = 800 V	25			kV/μs

## Transmission Characteristics

General test conditions and V<sub>DD1</sub>=V<sub>DD2</sub> = 5V, Ta = 25°C (unless otherwise specified).

PARAMETERS	CONDITIONS	Min.	Typ.	Max.	Unit	
Maximum Data Rate				500	kbps	
<b>DRIVER</b>						
t <sub>PLH</sub> , t <sub>PHL</sub>	Propagation Delay	No load, C <sub>L1</sub> = C <sub>L2</sub> = 100 pF, Figure7		400	ns	
t <sub>r</sub> , t <sub>f</sub>	Rise/Fall Time			100	ns	
<b>RECEIVER</b>						
t <sub>PLH</sub> , t <sub>PHL</sub>	Propagation Delay	C <sub>L</sub> = 15 pF, Figure8		60	150	ns
t <sub>SKEW</sub>	Differential Skew (  T <sub>PLH</sub> - T <sub>PHL</sub>   )				20	ns
t <sub>r</sub> , t <sub>f</sub>	Bus rise/fall time			25		ns

## Physical Specifications

PARAMETERS	Value	Unit
Weight	0.4(Typ.)	g

## Typical Performance Curves

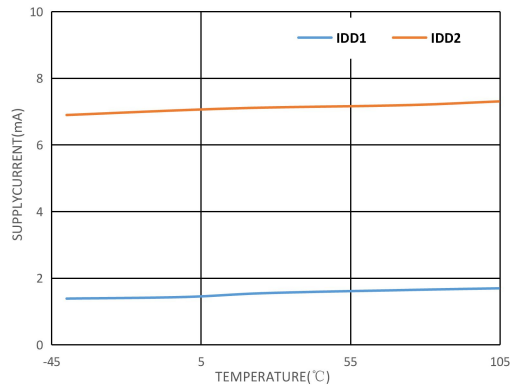

Figure1. Unloaded Supply Current vs. Temperature

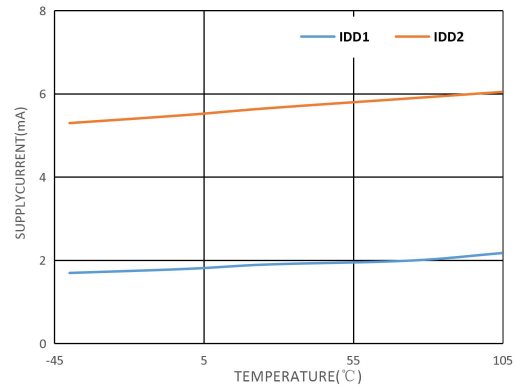

Figure2. Transmit Current vs. Temperature, VDD1=5V, VDD2=5V

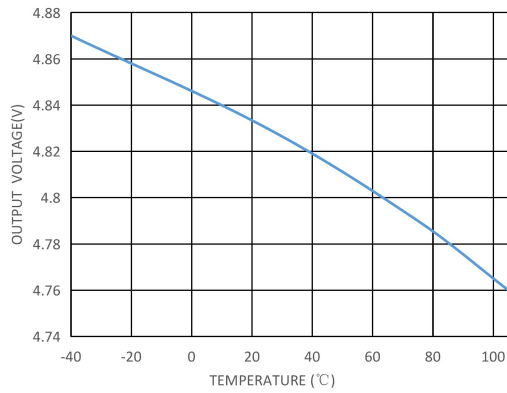

Figure3. Receiver Output High Voltage vs. Temperature, VDD1=5V, VDD2=5V

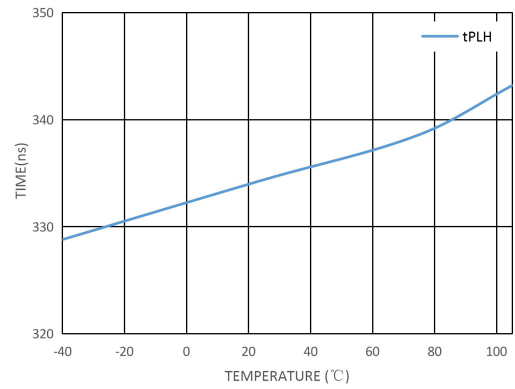

Figure4. Driver Propagation Delay vs. Temperature

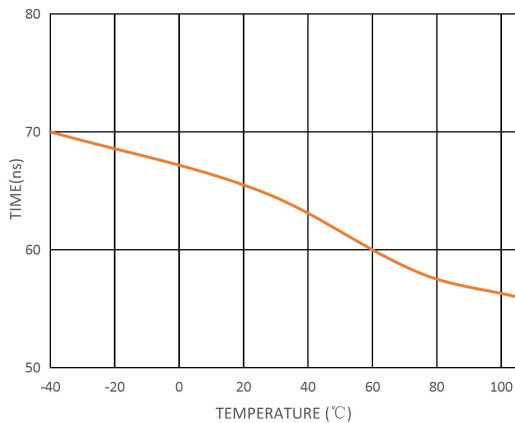

Figure 5. Receiver Propagation Delay vs. Temperature

## Test Circuits

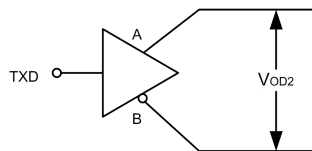

Figure 6. Driver Test Circuit

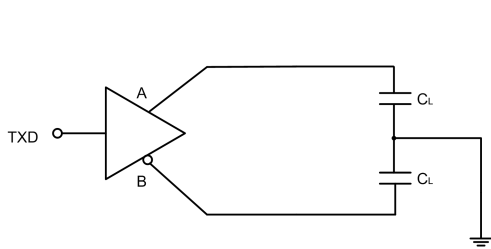

Figure 7. Drive propagation delay test circuit and wave forms

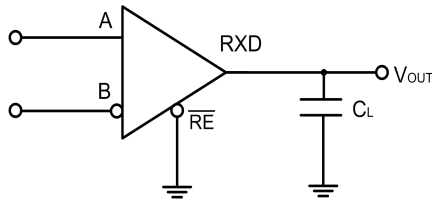
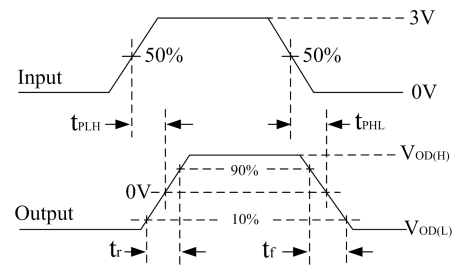
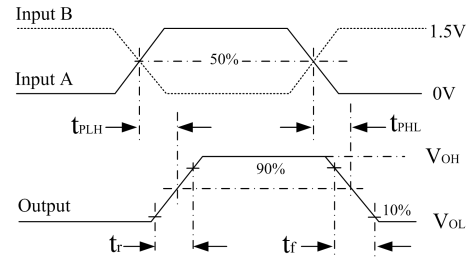

Figure 8. Receiver propagation delay test circuit and wave forms



## Detailed Description

TD041S485H-A is an advanced RS-485 transceivers. They each contain one driver and one receiver. These devices feature a fail-safe circuitry that guarantees a high receiver output voltage when the receiver inputs are either open, shorted or when they are connected to a terminated transmission line with all drivers disabled. TD041S485H-A operates with a two power supply. Their logic side supports 3.3V and 5V logic level conversion. The whole machine can monitor the overall working state of the module and limit the output high current to prevent the bus from overload or short circuit causing unrecoverable damage to the transceiver.

**Receiver input filter:** TD041S485H-A receiver have an integrated input filter which enhances noise immunity of the high-speed differential signals. The receiver propagation delay increases due to this filtering.

**Bus fail-safe:** Ordinary RS485 bus receivers will be in an indeterminate state when  $-200\text{mV} < A - B < 10\text{mV}$ . This situation can occur whenever the data bus is not being actively driven. The advanced Fail-safe feature of the TD041S485H-A guarantees a high receiver output voltage if the receiver's differential inputs are either shorted, open circuit, or if they are connected to a termination resistor.

The TD041S485H-A receiver thresholds are very precise, and the offset between threshold voltage and ground has a margin of at least 10mV. This guarantees that the receiver output is a high voltage even the input differential is zero volts, thus maintaining compliance with the EIA/TIA-485 standard.

**Load abilities on the bus (256 nodes):** The standard receiver input impedance of RS-485 is 12k $\Omega$  (1 unit load). A standard RS485 driver can drive at least 32 unit loads. The TD041S485H-A transceiver is designed to 1/8th of the standard unit load and the input impedance is higher than 96k $\Omega$ , hence allowing up to 256 unit loads. The TD041S485H-A can work combined with other standard RS485 that use the smaller amount of unit loads.

**Driver output protection:** The device prevents excessive output current caused by fault conditions or driver short circuit. A driver current limit on the output stage provides and ensures immediate protection against short circuits over the entire common mode voltage range.

**Automatic switching function:** The product integrates an automatic switching unit so that no longer requires the need to pass through the node to send and receive control signals, which to a certain extent, reduces the design complexity.

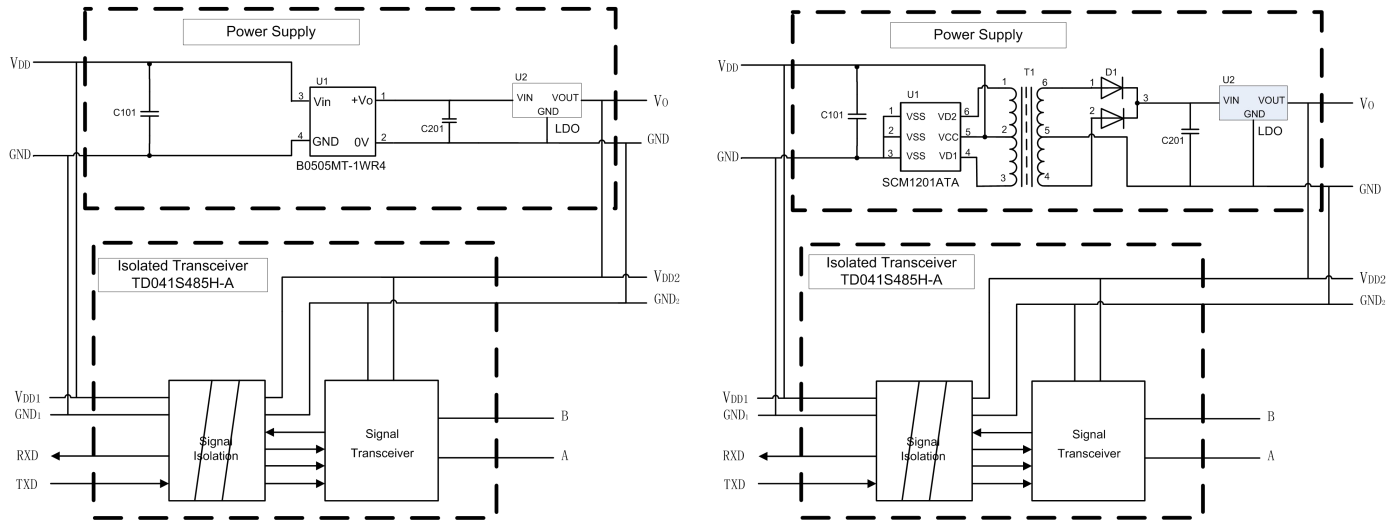

Figure 9. Typical application circuit

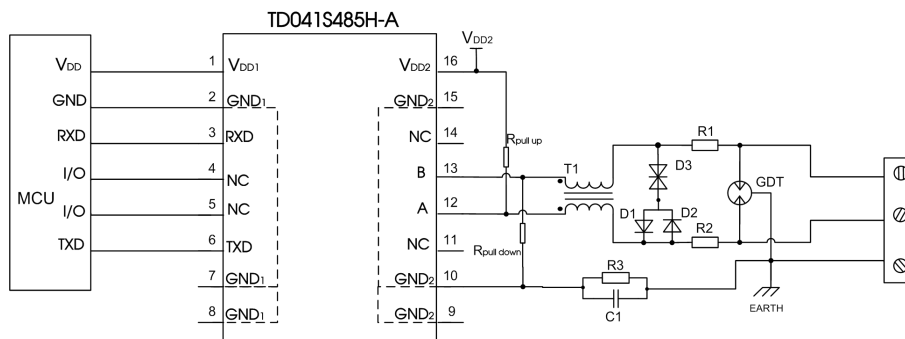

Figure 10. Port protection circuit for harsh environments

Recommended components and values:

Component	Recommended part, value	Component	Recommended part, value
R3	1MΩ	R1、R2	2.7Ω/2W
C1	1nF, 2kV	D1、D2	1N4007
T1	ACM2520-301-2P	D3	SMBJ8.5CA
GDT	B3D090L		

As the modules internal A / B lines come with its own ESD protection, which generally satisfy most application environments without the need for additional ESD protection devices. For harsh and noisy application environments such as motors, high voltage/current switches, lightning and similar however, we recommended that the user protects the module' s A / B lines with additional measures and external components such as TVS tube, common mode inductors, Gas discharge tube, shielded twisted pair of wires with the same single network Earth point. Figure 10 shows our recommended circuit diagram for such type of applications with components and values given in the table above. This recommendation is for reference only and may have to be adapted accordingly with appropriate component values in order to match the actual situation and application.

Note 1: Select the  $R_{terminal}$  according to the actual application.

Note 2: When using the port protection circuit, you need to slow down the baud rate.

## Using Suggests

- ① Hot-swap is not supported.
- ② If the external input of TXD is insufficient, the pull-up resistor should be added according to the situation.
- ③ Refer to IPC 7093 for the welding process design of this product. For detailed operation guidance, please refer to *Hot Air Gun Welding Operation Instruction for DFN Package Product* or *Welding Operation Instruction for DFN Package Product*.

## Ordering Information

Part number	Package	Number of pins	Product Marking	Tape & Reel
TD041S485H-A	DFN	16	TD041S485H-A	500/REEL

## Package Information

THIRD ANGLE PROJECTION 

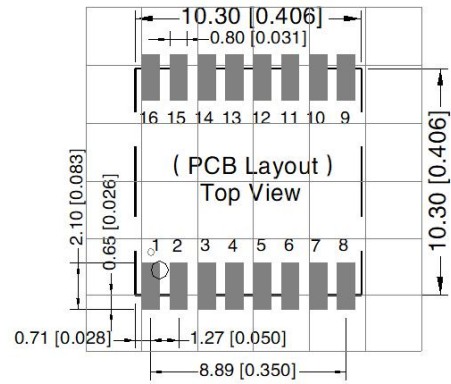
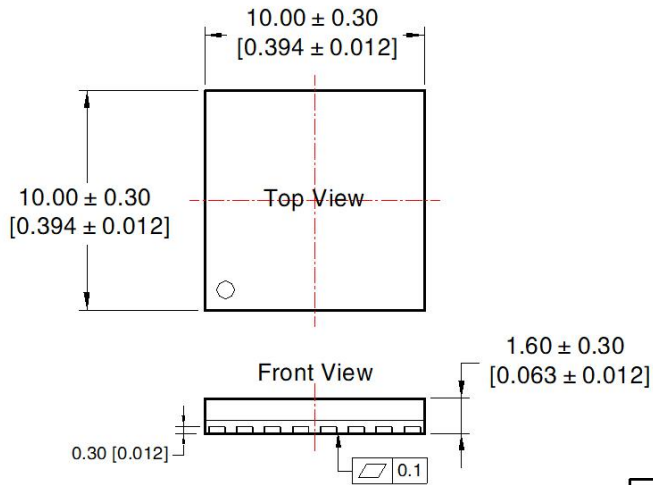

Note: Grid 2.54\*2.54mm

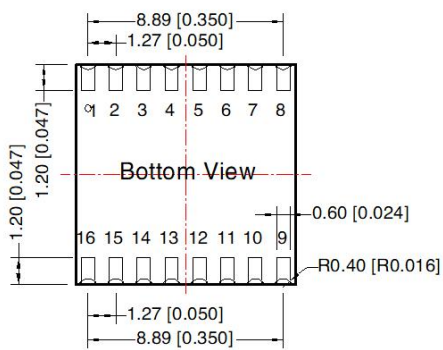

Note:  
 Unit: mm[inch]  
 General tolerances:  $\pm 0.10$  [± 0.004]

Pin-Out			
Pin	Mark	Pin	Mark
1	V <sub>DD1</sub>	9	GND <sub>2</sub>
2	GND <sub>1</sub>	10	GND <sub>2</sub>
3	RXD	11	NC
4	NC	12	A
5	NC	13	B
6	TXD	14	NC
7	GND <sub>1</sub>	15	GND <sub>2</sub>
8	GND <sub>1</sub>	16	V <sub>DD2</sub>



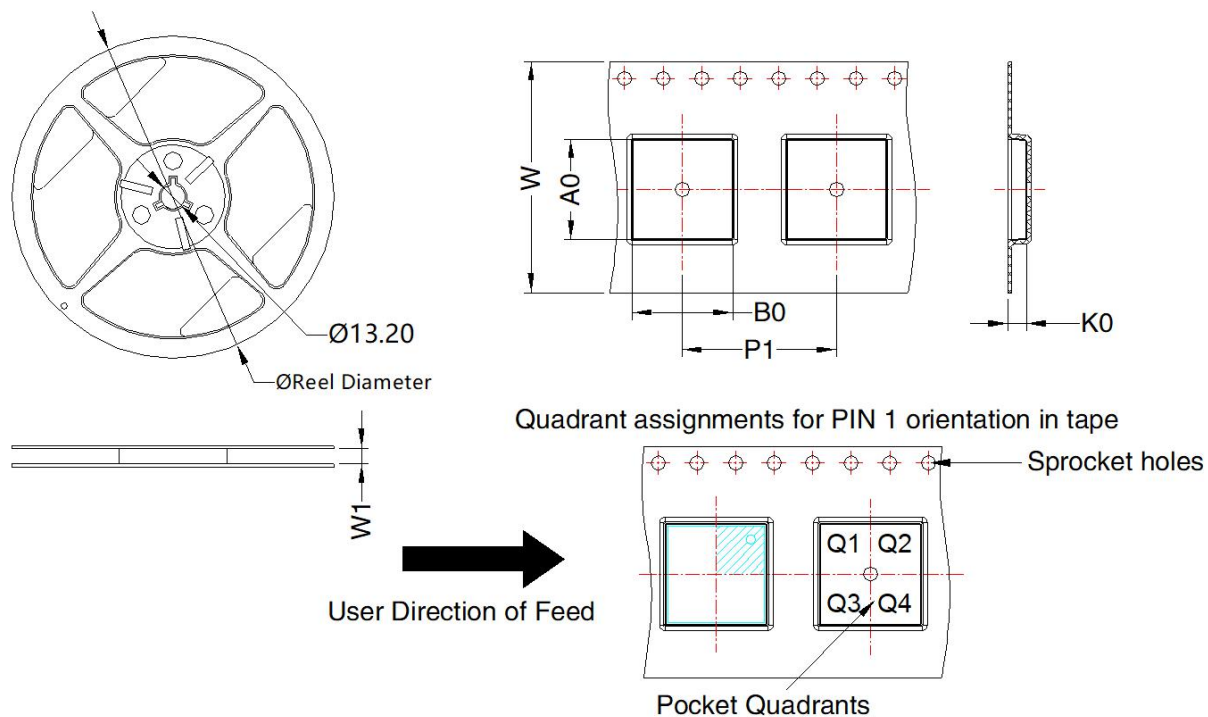

Device	Package Type	Pin	MPQ	Reel Diameter (mm)	Reel Width W1 (mm)	A0 (mm)	B0 (mm)	K0 (mm)	P1 (mm)	W (mm)	Pin1 Quadrant
TD041S485H-A	DFN 10x10	16	500	180.0	24.4	10.44	10.44	2.0	16.0	24.0	Q2

## MORNSUN Guangzhou Science & Technology Co., Ltd.

Address: No. 5, Kehui St. 1, Kehui Development Center, Science Ave., Guangzhou Science City, Huangpu District, Guangzhou, P. R. China  
 Tel: 86-20-38601850 Fax: 86-20-38601272 E-mail: [info@mornsun.cn](mailto:info@mornsun.cn) [www.mornsun-power.com](http://www.mornsun-power.com)