

SCM9601A Ultra-high Voltage Start-up Controller

Features

- Ideal for applications requiring an ultra-wide input voltage range (40VDC to 700VDC)
- Low-cost design featuring large starting current in small physical package
- Output short circuit sleep time that can be adjusted through the VDD bypass capacitance
- Charging voltage limit of VDD

Package



Mechanical package: SOT-23
(see "Ordering information" for details).

Applications

- Used for converters with ultra-wide input voltage of 40VDC to 700VDC.

Functional Description

The SCM9601A has a built-in 700V high voltage transistor that can operate with an input voltage from 40VDC up to 700VDC. The output is a constant charging current into the bypass capacitor of the switching power supply to start the controller chip. After the controller started up, the starter continues to deliver power for some time and increases the capacitive load capability of the power supply. In addition, SCM9601A can be used in combination with our SCM9602A to increase the input voltage even further covering a range from 40VDC up to 5,000VDC.

To avoid damage to the controller and the power system, the SCM9601A can sense the appropriate fault protection mode if the VDD bypass capacitor is too small or when the power supply output is in short circuit condition.

Typical Application Circuit

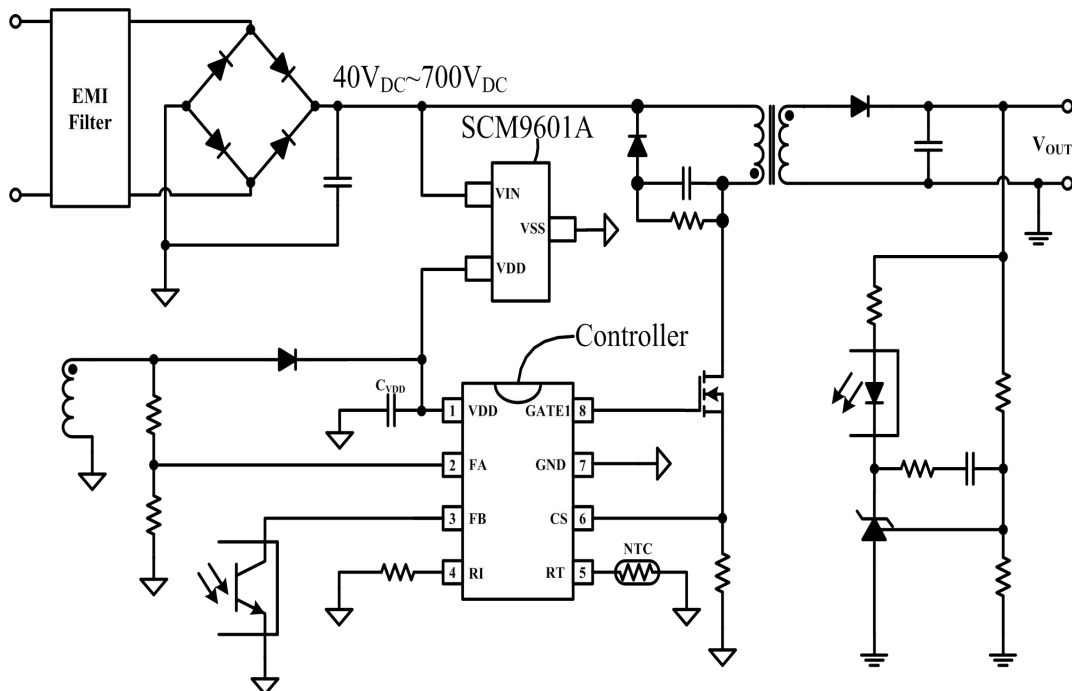

Application shown with an Input Voltage range of 40VDC to 700VDC where SCM9601A is used individually

Contents

| | | | |
|---------------------------------------|---|---|---|
| Features And Package..... | 1 | Typical performance Curves..... | 3 |
| Applications..... | 1 | Parameters test Circuit..... | 4 |
| Functional Description..... | 1 | Start-up Sequence,Input connected with the VIN Pin..... | 4 |
| Typical Application Circuit..... | 1 | Start-up Sequence,Drain connected with the VIN Pin..... | 4 |
| Pins And Internal Block Diagram..... | 2 | Fault Protection..... | 5 |
| Pin Descriptions..... | 2 | Application Circuit..... | 6 |
| Absolute Maximum Ratings..... | 2 | Power Supply Recommendations..... | 6 |
| Recommended Operating Conditions..... | 2 | Ordering、Package And Tape&Reel..... | 7 |
| Electrical Characteristics..... | 3 | | |

Pins

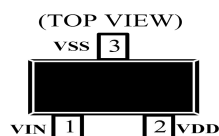

Internal Block Diagram

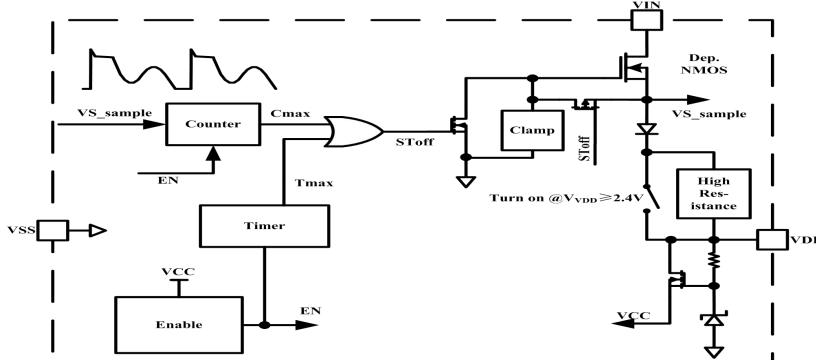

Pin Descriptions

| Pin No. | Pin Name | I/O | Description |
|---------|----------|-----|--|
| 1 | VIN | P | The high voltage input obtains power from the input voltage and charges the bypass capacitor of the VDD pin to start the controller. |
| 2 | VDD | P | Powers controller. This pin requires to be connect to GND via an external bypass capacitor. |
| 3 | VSS | P | IC Ground connection |

Absolute Maximum Ratings

General test conditions: Free-air, normal operating temperature range (unless otherwise specified).

| Parameter | Symbol | Min | Max | Unit |
|---|-----------------------------|-----|------|------|
| Bias mains voltage | V_{VDD} | | 40 | V |
| Voltage at the VIN pin | V_{VIN} | | 700 | |
| Operating junction temperature | T_J | -40 | 150 | °C |
| Storage temperature | T_{STG} | -40 | 150 | |
| Lead temperature for soldering (0.6mm from the case within 10s) | | | 260 | |
| Electrostatic Discharge (ESD) rating | Human body model (HBM) | | 2000 | V |
| | Charging device model (CDM) | | 1000 | |

Recommended Operating Conditions

| Parameter | Symbol | Min | Max | Unit |
|--------------------------------|-----------|-------|-----|------|
| Bias mains voltage | V_{VDD} | 9 | 20 | V |
| VDD bypass capacitance | C_{VDD} | 0.047 | 22 | uF |
| Operating junction temperature | T_J | -40 | 125 | °C |

| Symbol | Parameter | Test condition | Min | Typ | Max | Unit |
|------------------|---------------------------------------|---|-----|-------|-----|--------------------|
| POWER | | | | | | |
| I_{STL} | Minimum charging current of VDD | $V_{VIN}=40V, V_{VDD}=0V$ | 250 | 400 | 550 | μA |
| I_{STH} | Maximum charging current of VDD | $V_{VIN}=40V, V_{VDD}=3.5V$ | 0.8 | 2.5 | 4 | mA |
| I_{VIN_OFF} | VIN turn-off current | $V_{VIN}=40, V_{VDD}=22V$, after a delay of 88ms | | | 5 | μA |
| I_{VDD} | Operating current | $I_{VIN}=0, V_{VDD}=10V$ | 40 | | 150 | μA |
| V_{CM} | Charging voltage limit | $C_{VDD}=47nF$ | | 22 | | V |
| V_{VDD_START} | Oscillation voltage of oscillator | | | 4.3 | | V |
| V_{VDD_RESET} | Reset voltage of start-up circuit | | | 3.1 | | V |
| TIMING | | | | | | |
| T_{OSC} | Oscillation period of oscillator | $V_{VDD}=4.3V$ | | 22 | | μS |
| | | $V_{VDD}=18V$ | | 3.1 | | μS |
| | | $V_{VDD}=22V$ | | 1.5 | | μS |
| T_{CH} | Duration of high-voltage power supply | T_{CH1} —Input connected with the VIN pin | | 49152 | | $T_{OSC}^{Note 1}$ |
| | | T_{CH2} —Drain electrode connected with the VIN pin | | 2048 | | T_{OSC} |

Note 1: $T_{CH1}=49152 * T_{OSC}$.

Typical Performance Curves

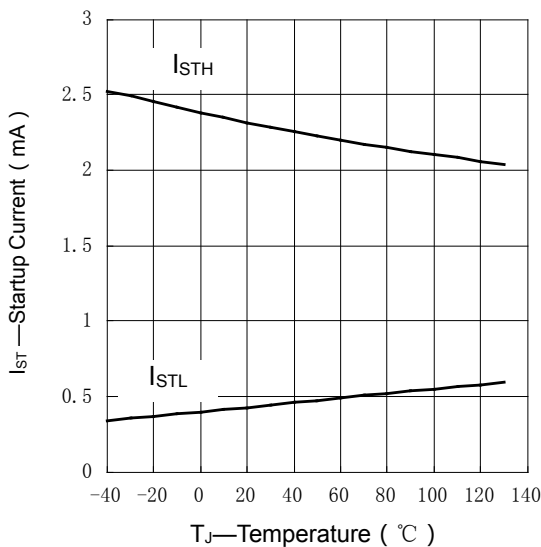

Fig. 1 Starting Current versus Temperature

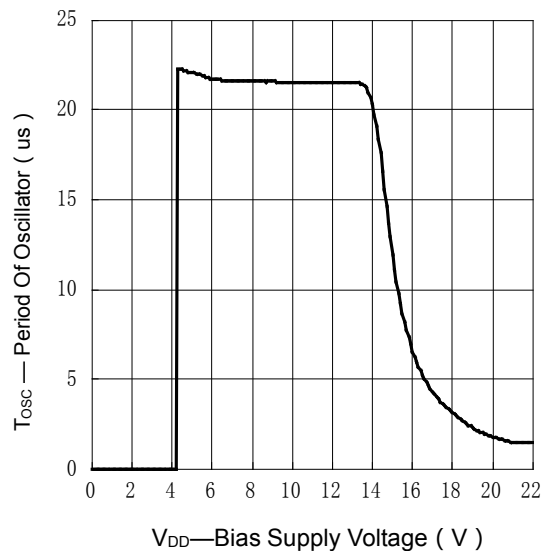

Fig. 2 Clock Period versus VDD Supply Voltage

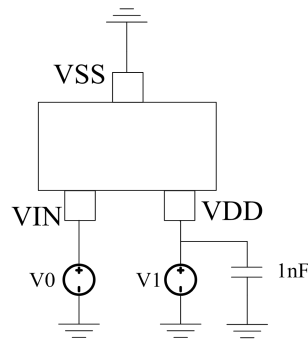

Fig. 3 Maximum Starting Current Test Circuit

Start-up Sequence, Input connected with the VIN pin

The converter input voltage powers the SCM9601A which charges the bypass capacitor C_{VDD} to start the controller. Once the switching power supply is on, SCM9601A keeps running for some time. It continues obtaining power from the input voltage to maintain normal operation of the controller and to improve the capacitive load capability of the switching power supply. As shown in Fig.4, after power on, the start-up circuit of the SCM9601A charges the bypass capacitor C_{VDD} with the minimum current I_{STL} while V_{VDD} remains below 2.4V. When V_{VDD} exceeds the 2.4V level, the start-up circuit of the SCM9601A starts charging the bypass capacitor C_{VDD} with the maximum current I_{STH} . At the point where V_{VDD} is close to 4.3V, the internal oscillator of the SCM9601A starts and closes the start-up circuit after T_{CH1} time elapses. After this time, it stops obtaining power from the input voltage, and V_{DD} will gradually approach the auxiliary winding voltage level V_A . The SCM9601A still supplies the power to the controller during the entire timing cycle. Only if the controller's current requirement after start is higher than I_{STH} , the VDD voltage will drop (not shown in Fig.4), otherwise it just keeps increasing until approaching the charging voltage limit V_{CM} (shown in Fig.4).

Refer to the "Electrical characteristics" table for I_{STL} , I_{STH} , T_{CH1} and V_{CM} values.

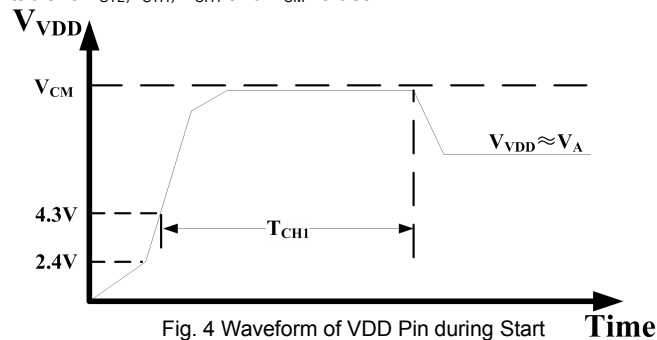

Fig. 4 Waveform of VDD Pin during Start

Start-up Sequence, Drain connected with the VIN pin

Start of drain of the main power switch connected with the VIN pin is similar to start of the input connected with the VIN pin: When V_{VDD} is below 2.4V, the charge current is at the minimum I_{STL} and when V_{VDD} is above 2.4V, the charge current is at the maximum I_{STH} . The difference between the two affects the starting time and the duration of the timing. After starting, the controller output enables a driving signal (Fig.5), creating a pulse waveform voltage V_{DS} at the drain of the main power switch. The SCM9601A sets the starting point of the timing by detecting and calculating the number of rising edges of the pulse waveform. On the sixth rising edge of the pulse waveform, SCM9601A closes the start-up circuit after T_{CH2} and stops obtaining power from the input voltage, and resulting in V_{VDD} gradually approaching the auxiliary winding voltage V_A .

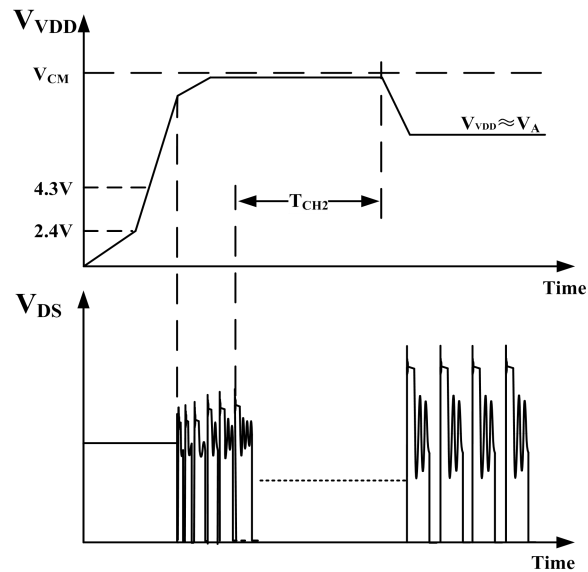

Fig. 5 Waveform of VDD Pin during Start

Fault protection

The SCM9601A can sense the appropriate protection mode for following two fault conditions:

1. Bypass capacitance at VDD pin too small;
2. Output of the power supply in short circuit condition.

Fig. 6 below shows a fault condition after the controller has been operating normally for some time and then entering the corresponding protection mode. For convenient description, the Fig. 5 is not drawn in strict line with the related voltages and time. V_{GATE} is the voltage driving signal for the main power switch.

Bypass capacitance at VDD pin too small

If the bypass capacitance is too small, the VDD pin voltage will have steep rising slope during start, resulting in VDD pin voltage overshoot which could potentially damage the post-stage controller if not properly handled. Therefore the SCM9601A limits V_{VDD} to V_{CM} during start, which is the safety voltage range of the controller, hence protecting the controller from damage by overvoltage due to a too small bypass capacitance C_{VDD} or due to a timing duration that is too long.

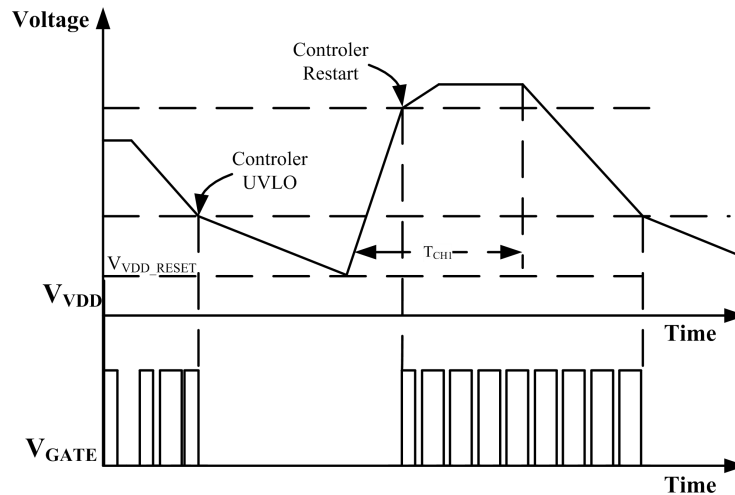

Fig. 6 Waveform and Time Sequence of Output Short Circuit Protection Mode

Output of the power supply in short circuit condition

Fig.6, Stage 1: In the case of an output short circuit, the controller cannot obtain enough energy from the auxiliary winding to maintain normal operation; V_{VDD} drops to the undervoltage lockout threshold (UVLO) of the controller. At this point, the controller the GATE outputs signal is still enabled.

Fig.6, Stage 2: At the undervoltage lockout stage, the controller does no longer consume any energy from the bypass capacitor C_{VDD} , only the SCM9601A chip does. The bypass capacitor C_{VDD} 's discharge current I_{VDD} becomes relatively small and therefore voltage V_{VDD} of the bypass capacitor takes more time to drop to V_{VDD_RESET} level.

Fig.6, Stage 3: When V_{VDD} is equal to V_{VDD_RESET} , SCM9601A again begins to charge the bypass capacitor C_{VDD} with the maximum current I_{STH} until the time T_{CH1} elapses. In the process, the controller is restarted (Controller Restart in Fig.6), re-enabling the GATE driving signal output. This is basically assuming, that the necessary current for the controller operation is smaller than the maximum current I_{STH} , so V_{VDD} can keep rising and approaching the charging voltage limit V_{CM} . If an output short circuit condition remains at the end of time T_{CH1} , VDD will drop once again back into stage 1 and starts a new cycle of output short circuit protection until the output short circuit is no longer present.

The time between controller undervoltage and controller restart is also called "short circuit protection sleep time" during which the switching power supply can run a cooling cycle. This time can be adjusted by means of the bypass capacitor C_{VDD} value.

Application Circuit

1. When the maximum input voltage is lower than 700VDC, the SCM9601A can be used as the high-voltage startup circuit. For details, please refer to the typical application circuit.
2. When applied to a higher input voltage range, it is recommended to use our SCM9602A, please refer to Fig.7. C1 and C2 are input high-voltage storage capacitors to slow the fluctuation of input voltage; R1 and R2 are equalization Resistance, avoiding the uneven voltage problem caused by the difference between C1 and C2 leakage current; D1, D2 and D3 are used to solve the current backflow problem caused by the large difference between C1 and C2 leakage current.

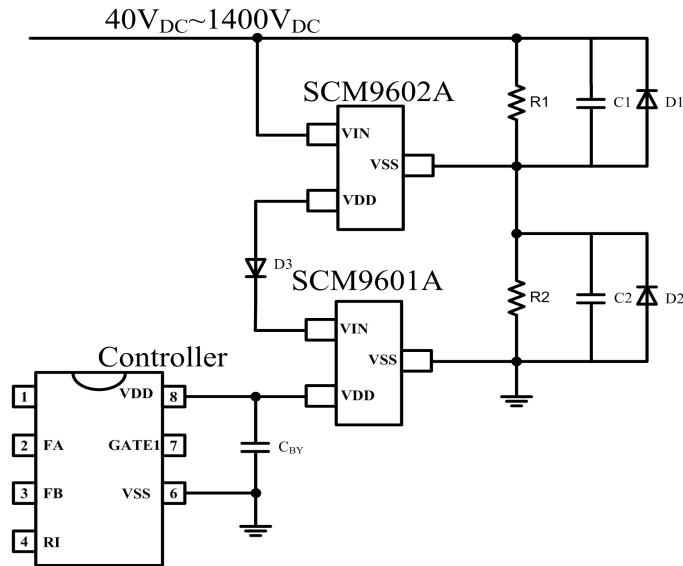

Fig. 7 Input 40VDC~1400VDC application circuit (SCM9601A and SCM9602A are used in series)

Power Supply Recommendations

1. When the SCM9601A draws power from the input terminal and charges the VDD bypass capacitor, the capacitor CVDD is recommended to be below 22 μ F.
2. When SCM9601A and SCM9602A are used in series, the leakage current difference between capacitors C1 and C2 should be considered.

Ordering Information

| | | | | |
|-------------|---------|----------------|-----------------|-------------|
| Part number | Package | Number of pins | Product Marking | Tape & Reel |
| SCM9601ATA | SOT-23 | 3 | 9601 | 3K/REEL |

Product model number and screen printing instructions
SCM9601XYZ:

- (1) SCM9601 = Product designation.
- (2) X = Version code information (A-Z).
- (3) Y = Packaging definition code; T for SOT package.
- (4) Z = Operating temperature range (C = 0°C to +70°C, I = -40°C to +85°C, A = -40°C to +125°C, M = -55°C to +125°C).
- (5) YM: Date code for product traceability; Y = code for production year; M = code for production month

Package Information (SOT-23)

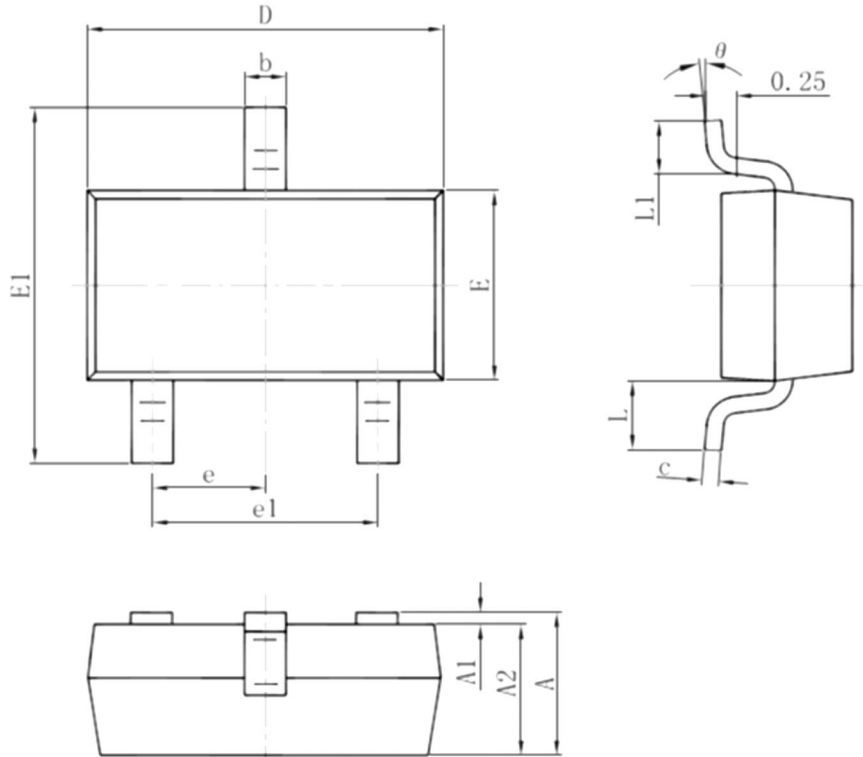

| SOT-23 | | | | |
|--------|-----------------------|---------|-----------------------|---------|
| Mark | Dimensions (mm) | | Dimensions (") | |
| | Minimum | Maximum | Minimum | Maximum |
| A | 0.900 | 1.150 | 0.035 | 0.045 |
| A1 | 0.000 | 0.100 | 0.000 | 0.004 |
| A2 | 0.900 | 1.050 | 0.035 | 0.041 |
| b | 0.300 | 0.500 | 0.012 | 0.020 |
| c | 0.080 | 0.150 | 0.003 | 0.006 |
| D | 2.800 | 3.000 | 0.110 | 0.118 |
| E | 1.200 | 1.400 | 0.047 | 0.055 |
| E1 | 2.250 | 2.550 | 0.089 | 0.1 |
| e | 0.950 Typical value | | 0.037 Typical value | |
| e1 | 1.800 | 2.000 | 0.071 | 0.079 |
| L | 0.550 reference value | | 0.022 reference value | |
| L1 | 0.300 | 0.500 | 0.012 | 0.020 |
| θ | 0° | 8° | 0° | 8° |

7

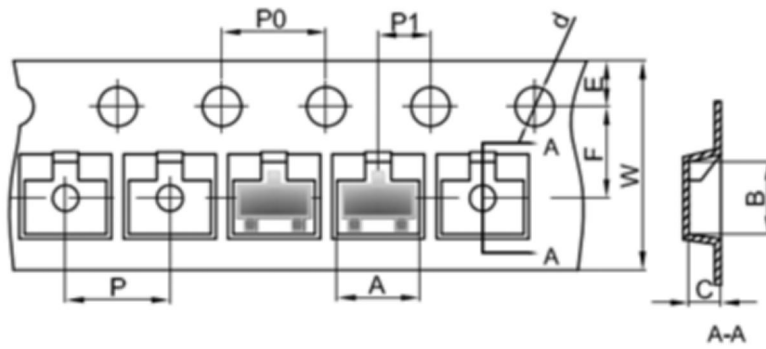

| Dimensions (mm) | | | | | | | | | |
|-----------------|--------|--------|--------|--------|--------|--------|--------|--------|-----------|
| Mark | A | B | C | d | E | F | P0 | P1 | W |
| SOT-23 | 3.15 | 2.77 | 1.22 | Φ1.50 | 1.75 | 3.50 | 4.00 | 2.00 | 8.00 |
| Tolerance | +/-0.1 | +/-0.1 | +/-0.1 | +/-0.1 | +/-0.1 | +/-0.1 | +/-0.1 | +/-0.1 | +0.3/-0.1 |

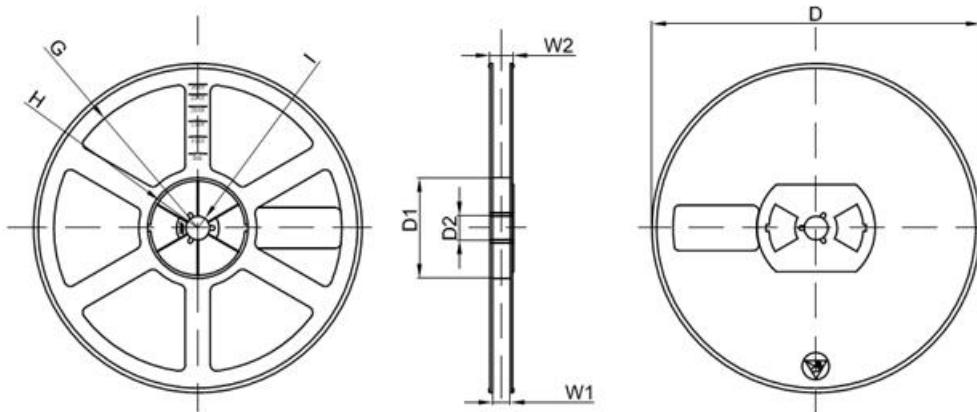
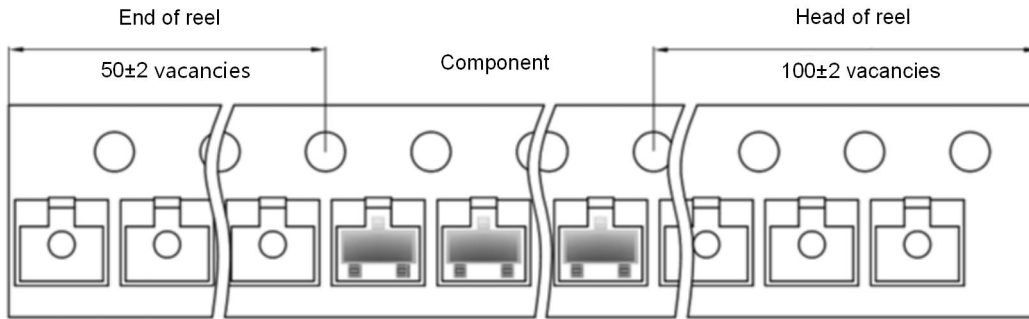

| Dimensions (mm) | | | | | | | | |
|-----------------|---------|-------|-------|----------------|----------------|---------------|------|-------|
| Mark | D | D1 | D2 | G | H | I | W1 | W2 |
| 7" reel | Φ178.00 | 54.40 | 13.00 | 78.00 (radius) | 25.60 (radius) | 6.50 (radius) | 9.50 | 12.30 |
| Tolerance | +/-2 | +/-1 | +/-1 | +/-1 | +/-1 | +/-1 | +/-1 | +/-1 |

| | | | | | |
|---------|-----------------|-----------|------------------------|--------------|---------------------------|
| On reel | Reel dimensions | In carton | Carton dimensions (mm) | In plate box | Plate box dimensions (mm) |
| 3000PCS | 7" | 45,000PCS | 203*203*195 | 180,000PCS | 438*438*220 |

Note: The minimum order quantity is the minimum packing quantity, and the order quantity shall be an integral multiple of MPQ.

Mornsun Guangzhou Science & Technology Co., Ltd.

Address: No. 5, Kehui St. 1, Kehui Development Center, Science Ave., Guangzhou Science City, Luogang District, Guangzhou, P. R. China

Tel: 86-20-38601850

Fax: 86-20-38601272

E-mail: sales@mornsun.cn

