

SCM1301A High-Efficiency Wide Input-Voltage-Range 1A Buck Regulator

Features

- Input Range 4.5 V to 40 V with 45 V Transients
- 0.7 MHz Switching Frequency
- High Efficiency for Light Load Power Saving Mode
- Output Current up to 1 A
- Internal Compensation and Internal Soft-Start
- Overcurrent Protection and Overthermal Protection
- TSOT23-6L Package

Application

- Intelligent Instrument
- Collector
- Concentrator
- Industrial Distributed Power Applications

Description

The SCM1301A is a step-down (buck) regulator. With wide input range 4.5 V to 40 V, it is suitable for a wide range of applications from industry to automotive. An ultra-low 1.6 μ A shutdown current prolongs the battery life. The SCM1301A operates at 0.7MHz fixed frequency with small external components while still being able to have low output ripple voltage. Soft start and compensation circuits are implemented internally, and these allow the device to be used with minimum external components .

The SCM1301A is optimized for up to 1 A load current, and has a 0.765 V nominal feedback voltage.

The device has built-in overthermal protection and short protection, and is available in the TSOT23-6L package (2.9mm x 1.6mm x 0.8mm) .

Simplified Schematic

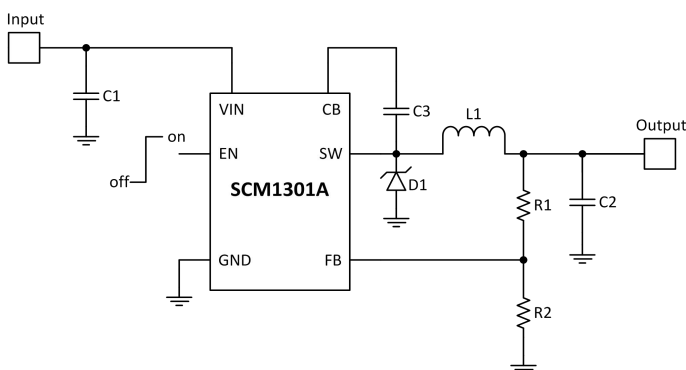

Packaging

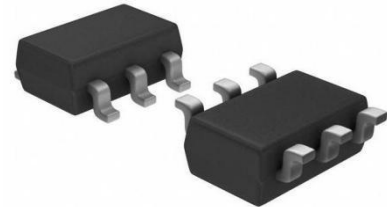

Product Package: TSOT23-6L
(see "Ordering information" for details)

Functional curve

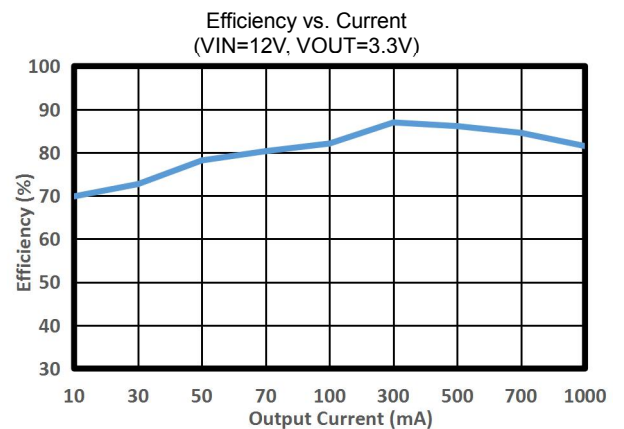

Contents

Features and Packaging.....	1	Features Description.....	6
Application.....	1	Application Information.....	7
Description.....	1	Applications Circuit.....	7
Simplified Schematic and Functional curve.....	1	Order, Packaging, and Packing.....	8
Pins and Description.....	2		
Absolute Maximum Ratings.....	3		
Recommended Operating Conditions.....	3		
Electrical Characteristics.....	3		
Typical curves.....	4		

Pins

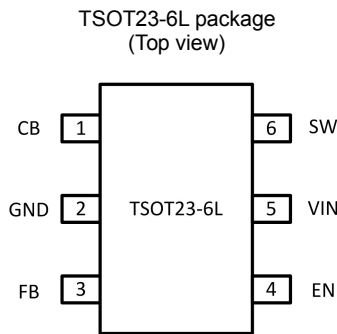

Functional Block Diagram

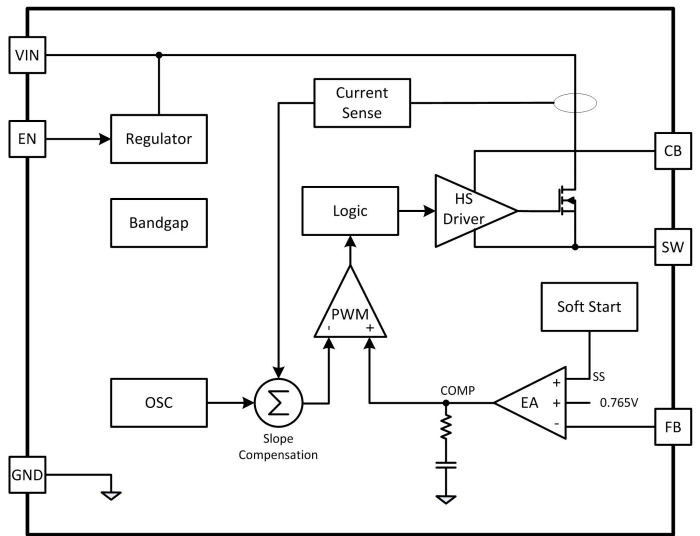

Pin Description

Pin No.	Pin Name	I/O	DESCRIPTION
1	CB	I	SW FET gate bias voltage. Connect C3 cap between CB and SW.
2	GND	G	Ground Connection.
3	FB	I	Feedback Pin. Set feedback voltage divider ratio with $V_{OUT} = V_{FB} (1 + (R1/R2))$
4	EN	I	Enable and disable input pin. Pulling this pin below the specified threshold or leaving it floating shuts the device down. Pulling it up above the specified threshold enables the device.
5	VIN	I	Power input voltage pin.
6	SW	O	Switch node. Connect to inductor, diode and C3 cap.

Absolute Maximum Ratings

General test conditions: free-air, normal operation temperature range (unless otherwise noted).

Parameters		MIN	MAX	UNIT
Input Voltages	V _{IN} to GND	-0.3	45	V
	EN to GND	-0.3	45	
	FB to GND	-0.3	6	
	CB to SW	-0.3	6	
Output Voltages	SW to GND	-1	45	V
Operating junction temperature	T _J	-40	150	°C
Storage temperature range	T _{STG}	-55	150	
Moisture sensitivity level	MSL	MSL3		
Electrostatic discharge (ESD)	Human body model (HBM)		2000	V
	Charged device model (CDM)		500	

Note: stresses at or beyond those listed under "absolute maximum rating" may cause permanent damage to the device. Exposure to absolute maximum rated conditions for extended periods may affect device reliability. All voltage values are based on the ground.

Recommended Operating Conditions

T_A=+25°C, unless otherwise noted.

Parameters		MIN	MAX	UNIT
Buck regulator	V _{IN}	4.5	40	V
	CB		45	
	CB to SW		5	
	SW	-0.7	40	
	FB	0	5	
Control	EN	0	40	V
Temperature	T _J	-40	125	°C

Electrical Characteristics

T_A=+25°C, V_{IN}=12V, EN=V_{IN}, unless otherwise noted.

Symbol	PARAMETER	TEST CONDITIONS	MIN	TYP	MAX	UNIT
VIN (INPUT POWER SUPPLY)						
V _{IN}	Operating input voltage		4.5		40	V
I _{SHDN}	Shutdown supply current			1.6	5	μA
V _{UVLO}	Undervoltage lockout thresholds	Rising			4.4	V
		Falling	3			V
I _Q	Quiescent current	Power-down Mode ,no load, V _{IN} = 12 V, not switching		46		μA
EN AND UVLO						
V _{EN}	EN Threshold Voltage	Rising			2.5	V
		Falling	0.8			V
I _{EN}	EN PIN current	EN=0		0.1		μA
HIGH-SIDE MOSFET						
R _{DS(on)_H}	On-resistance	V _{IN} =12V, CB - SW =5V		500		mΩ
t _{ON-MIN}	Minimum on time ⁽¹⁾			102		ns
D _{MAX}	Maximum duty cycle ⁽¹⁾			93		%
V _{FB}	Feedback voltage		0.746	0.765	0.784	V
CURRENT LIMIT						
I _{LIMIT}	Current limit threshold	V _{IN} =12V		1500		mA
f _{SW}	Switching frequency		550	700	850	kHz
THERMAL PERFORMANCE						
T _{SHUTDOWN}	Thermal shutdown trip point ⁽¹⁾	Rising		170		°C
T _{HYS}	Hysteresis ⁽¹⁾			10		°C

Note(1): Guaranteed by design.

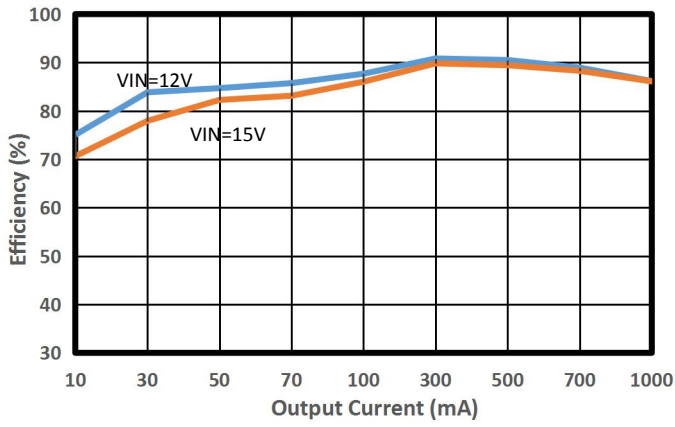

Figure 1. Efficiency vs. Load Current
(V_{OUT}=5V)

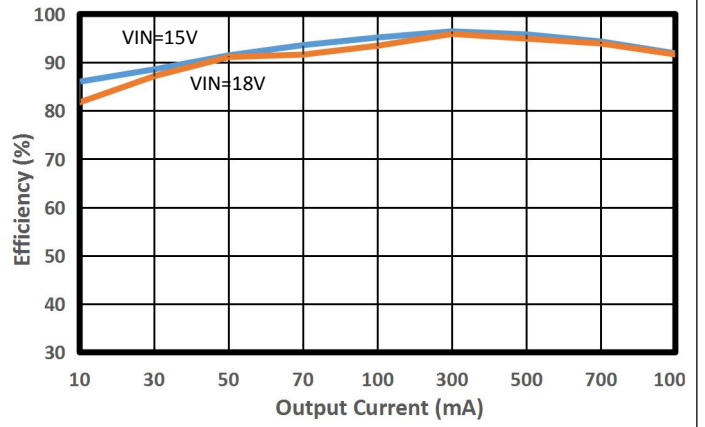

Figure 2. Efficiency vs. Load Current
(V_{OUT}=12V, L=47μH)

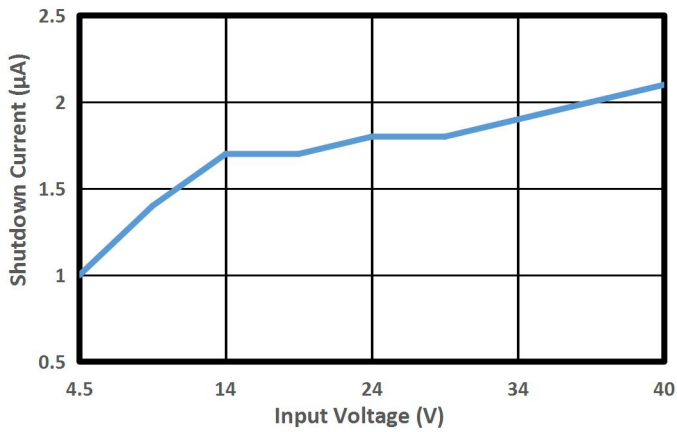

Figure 3. Input Voltage vs. Shutdown Current
(V_{OUT}=5V)

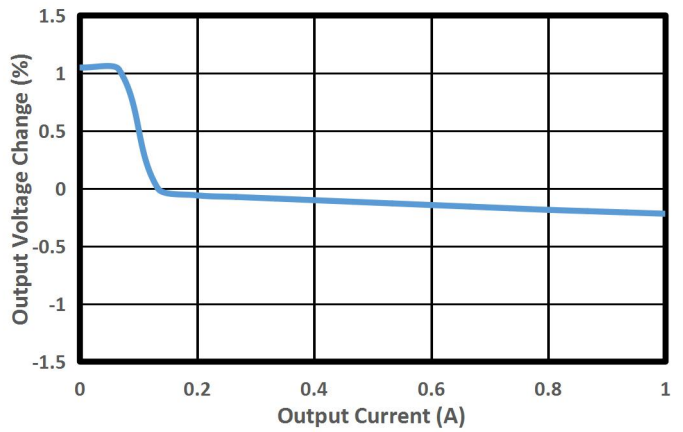

Figure 4. Load Regulation
(V_{OUT}=12V, L=47μH)

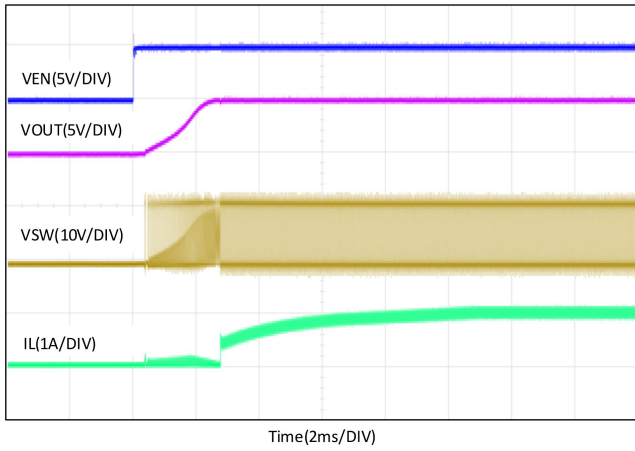

Figure 5. EN Start-up Waveform
(VIN=12V, VOUT=5V, ILOAD=1A)

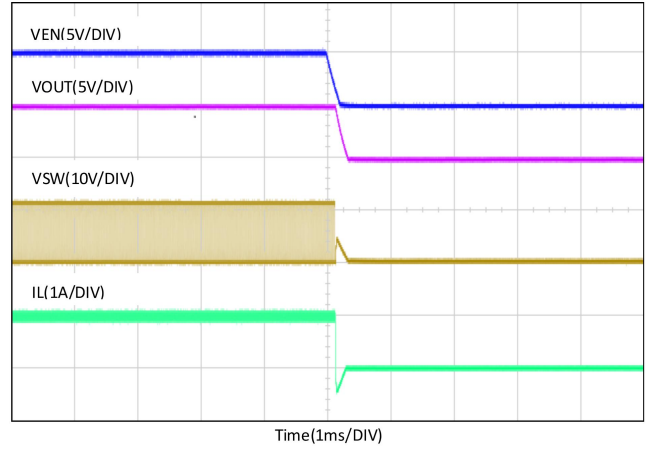

Figure 6. EN Shutdown Waveform
(VIN=12V, VOUT=5V, ILOAD=1A)

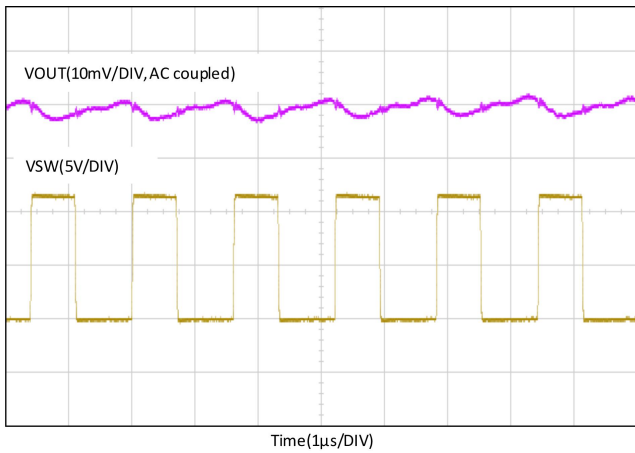

Figure 7. Switching Node and Output Voltage Waveform
(VIN=12V, VOUT=5V, ILOAD=1A)

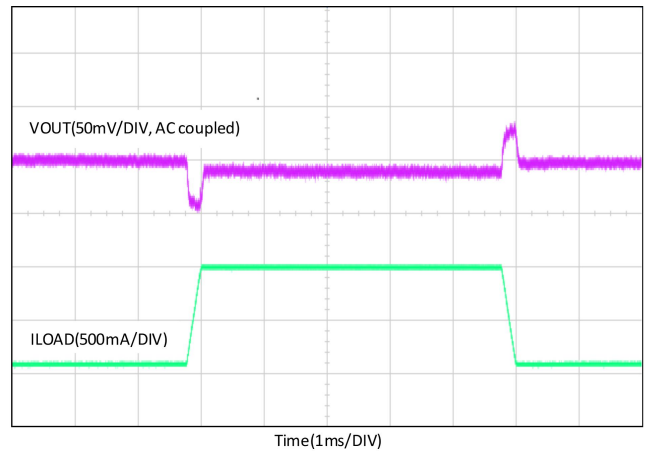

Figure 8. Load Transient Between 0.1A and 1A
(VIN=12V, VOUT=5V)

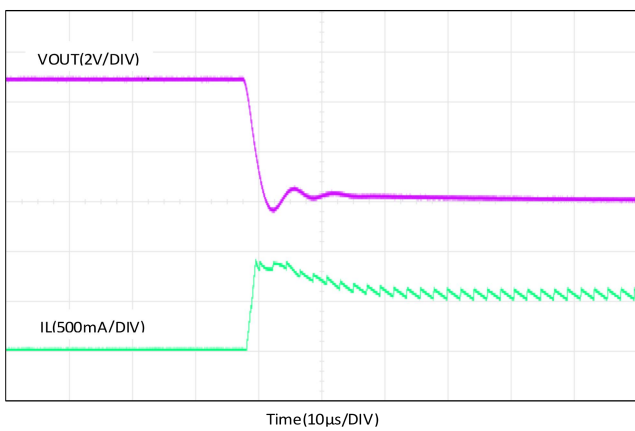

Figure 9. Short Circuit Test Waveform
(VIN=12V, VOUT=5V)

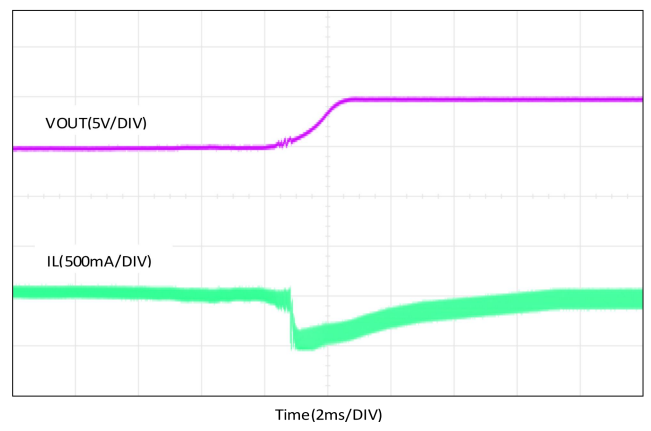

Figure 10. Short Circuit Recovery Waveform
(VIN=12V, VOUT=5V)

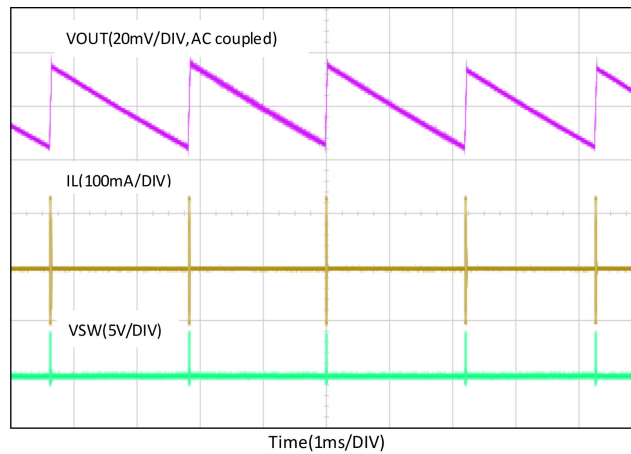

Figure 11. Light Load Mode Operation
(VIN=12V, VOUT=5V, No Load)

Functional Description

The SCM1301A is a 40 V, 1 A step-down (buck) regulator. The buck regulator has a very low quiescent current during the light load to prolong the battery life.

The SCM1301A improves performance by implementing a constant frequency and current mode control. The device uses the minimum external components due to compensation which is implemented internally. The SCM1301A has an integrated 5V regulator to provide the power for bootstrap capacitor. When the bootstrap voltage drops below the specified threshold, the high-side MOSFET is turned off using an UVLO circuit which allows the low side diode to conduct and refresh the charge on the CB capacitor. The SCM1301A can operate at high duty cycle with the bootstrap refresh function. The output voltage can be stepped down to as low as the 0.765 V reference. Internal soft start is featured to minimize input inrush currents.

PWM Mode

The SCM1301A operates at a fixed frequency, and implements peak current mode control. The output voltage is compared through external resistors on the FB pin to an internal voltage reference by an error amplifier which drives the internal COMP node. An internal oscillator initiates the turn on of the high side MOSFET, and the inductor current increases linearly. The SCM1301A senses the peak current, and high side MOSFET is turned off when the peak current reaches the threshold, which allows the low side diode to conduct and refresh the charge on the bootstrap capacitor, and the current through the inductor falls linearly to zero or the value when next cycle restarts.

Light Load Mode

The SCM1301A operates in light load mode at light load current. For Light load mode operation, most modules are turned off to improve efficiency by reducing losses.

EN and Internal Power Conversion

The internal power conversion circuit can be enabled when the EN pin is higher than 2.5V, then the high side MOSFET starts to switch. That will produce an output voltage and the device also be turned on. When EN is pulled down to 0 V, the device is turned off and enters the lowest shutdown current mode. In shutdown mode the supply current will be decreased to approximately 1.6 μ A. The device cannot be enabled if the EN pin is floating, and the maximum voltage to the EN pin should not exceed 40 V.

Bootstrap

The SCM1301A has an integrated boot regulator, and requires a small ceramic capacitor between the CB and SW pins to provide the gate drive voltage for the high side MOSFET. The boot capacitor is refreshed when the high side MOSFET is off and the low side diode conducts. When the bootstrap voltage drops below threshold, the high-side MOSFET is turned off using an UVLO circuit until the bootstrap voltage is greater than the specified threshold.

Current Limit

The SCM1301A implements current mode control which uses the internal COMP voltage to turn off the high side MOSFET on a cycle by cycle basis. Each cycle the switch current and internal COMP voltage are compared, when the peak switch current intersects the COMP voltage, the high side MOSFET is turned off. During overcurrent conditions that pull the output voltage low, the error amplifier will respond by driving the COMP node high, increasing the switch current. The error amplifier output is clamped internally, and the switch current will be limited on a cycle by cycle basis.

Thermal Shutdown

The device implements an internal thermal shutdown to protect itself if the junction temperature exceeds 170°C (typ). Once the junction temperature decreases below 160°C (typ), the device reinitiates the power up sequence.

Setting the Output Voltage

The output voltage is set using a feedback resistor divider(R1 and R2) as shown on the application schematic.

$$V_{FB} = V_{OUT} \times R2 / (R1 + R2) = 0.765V$$

The output voltage according to the following equation:

$$V_{OUT} = 0.765V \times (R1 + R2) / R2$$

To solve for R1 given R2 and VOUT uses the following equation:

$$R1 = R2 \times (V_{OUT} / 0.765 - 1)$$

Output Inductor Selection

The output inductor will produce a steady current when the high-side MOSFET is turned off. Lower ripple current and output voltage ripple will require a larger value of inductance, but the larger value of inductance means larger size, larger ESR, lower saturation current. A reasonable value is setting the ripple current to be 30% of the maximum DC output current, this will enable the SCM1301A to current limit without saturating the inductor. The value of inductance can be calculated using below equation:

$$L = V_{OUT} \times (V_{IN} - V_{OUT}) / (V_{IN} \times f \times \Delta I)$$

V_{OUT} is the output voltage, V_{IN} is the input voltage, f is the switching frequency, ΔI is the peak-to-peak inductor ripple current.

Input Capacitor Selection

The input current of buck regulator is discontinuous, so the input capacitor is needed to stabilize the input voltage. A low ESR capacitor, for example, ceramic capacitor, tantalum capacitor or low ESR electrolytic capacitor, is needed to prevent the noises and interferences appearing at the input. Using a $1\mu F \sim 10\mu F$ value with X7R or X5R dielectric is reasonable. The input capacitor must be placed close to the VIN pin in order to achieve the best performance when users design a PCB.

Output Capacitor Selection

The output capacitor will determine the DC output voltage and the loop stability. A low ESR capacitor will meet the better output voltage ripple. Using a $22\mu F$ ceramic capacitor to accomplish the best output voltage ripple and transient load response is reasonable.

The Schottky Diode Selection

The diode works as a freewheeling diode and supplies the current to the inductor when the high side MOSFET is turned off. To reduce losses due to the diode forward voltage, use a Schottky diode. Choose a diode whose maximum reverse voltage rating is greater than the maximum input voltage(transient overshoot voltage), and whose current rating is greater than the maximum load current.

Bootstrap Capacitor Selection

A $0.1\mu F \sim 1\mu F$ capacitor, X7R or X5R dielectric and a voltage rating is greater than 10V, is recommended, and a large value is preferable at high duty cycle.

Application Circuit

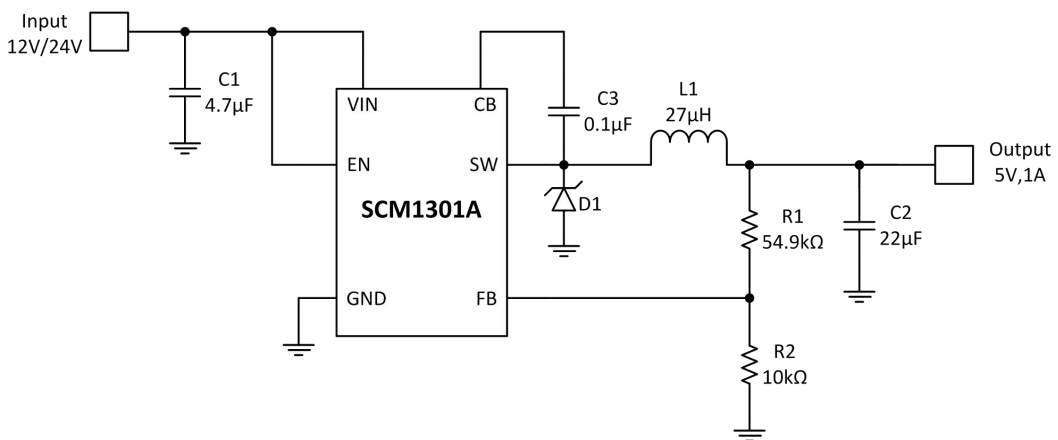

Ordering Information

Part number	Package	Number of pins	Product Marking	Tape & Reel
SCM1301ATA	TSOT23-6L	6	1301YM	3K/Reel

Product marking and data code:

- (1) SCM1301, Product designation.
- (2) A, Version code information.
- (3) T, Packaging definition code; T: TSOT23-6L package.
- (4) A, Operating temperature range; C: 0°C-70°C, I: -40°C-85°C, A: -40°C-125°C, M: -55°C-125°C.
- (5) YM, Data code for product traceability.

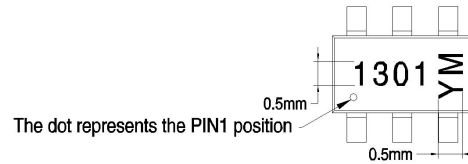

Note:

- 1、Typeface: Arial;
- 2、Character size:
Height: 0.5mm, Spacing: 0.1mm

Package Information

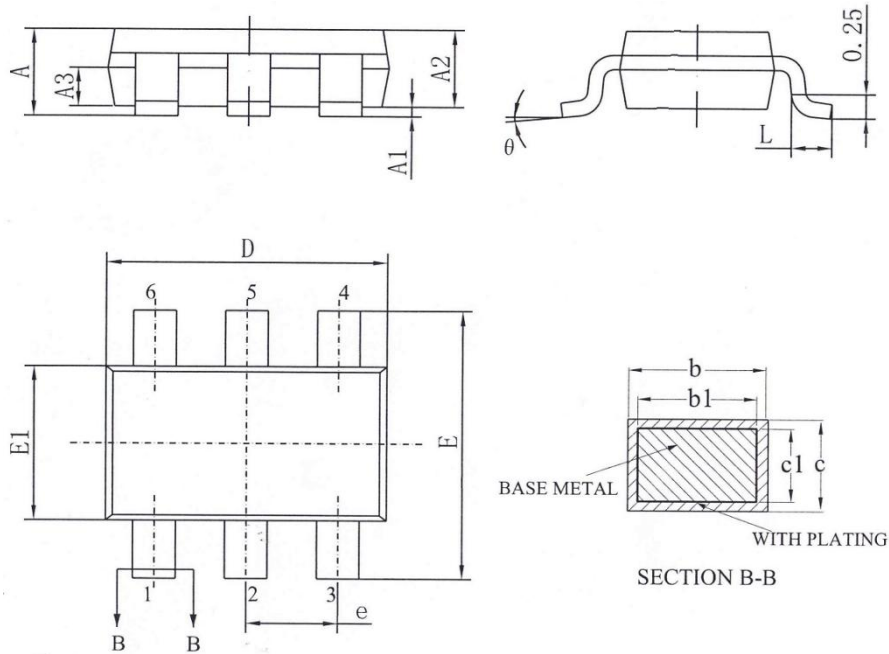

Symbol	Dimensions In Millimeter		
	Min.	Typ.	Max.
A	-	-	0.95
A1	0	-	0.10
A2	0.75	0.80	0.85
A3	0.35	0.40	0.45
b	0.30	0.44	0.50
b1	0.30	0.40	0.45
c	0.11	0.16	0.20
c1	0.11	0.13	0.15
D	2.70	2.90	3.10
E	2.60	2.80	3.00
E1	1.50	1.60	1.70
e	0.95BSC		
L	0.30	0.40	0.50
θ	0	-	8°

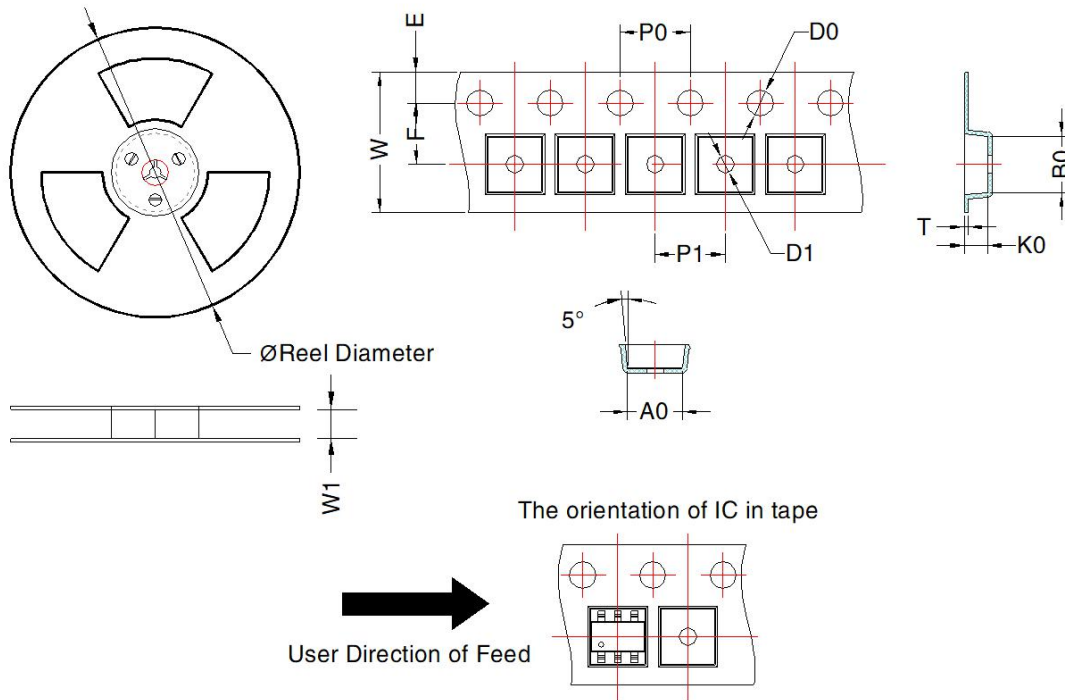

Device	Package Type	MPQ	Reel Diameter (mm)	Reel Width W1 (mm)	A0 (mm)	B0 (mm)	K0 (mm)	T (mm)	W (mm)	E (mm)	F (mm)	P1 (mm)	P0 (mm)	D0 (mm)	D1 (mm)
SCM1301ATA	TSOT-23-6	3000	180.0	8.5	3.17 ± 0.1	3.1 ± 0.1	1.1 ± 0.1	0.25 ± 0.03	8.0 ± 0.3	1.75 ± 0.1	3.5 ± 0.1	4 ± 0.1	4 ± 0.1	1.5 ± 0.1	1.0 ± 0.1

Note: The minimum order quantity is the minimum package quantity, the order quantity should be an integer multiple of MPQ.

Mornsun Guangzhou Science & Technology co., Ltd.

Address: No.5, Kehui St.1, Kehui Development Center, Science Ave., Guangzhou Science City, Luogang District, Guangzhou, P.R.China

Tel: 400-1080-300

Fax: 86-20-38601272

E-mail: sales@mornsun.cn