

SCM1201B 3.3-5V Transformer Driver for Isolated Power Supplies

Features

- Push-Pull driver controller
- 2.7-5.5V wide input voltage
- Low conduction resistance 200mΩ
- Two built-in power MOSFETs with high symmetry, quasi-complementary driver
- Limited MOSFET's current while turning on the power
- Over current protection and Short circuit protection
- Over temperature protection
- Under voltage protection
- Increase the dead time under light load

Application

- Isolated Interface Power Supply for CAN, RS-485, RS-232 etc.

Packaging

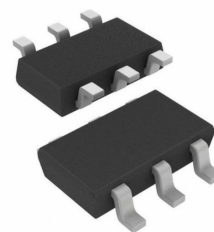

Optional Packaging of Product: TSOT-23-6 please refer to "Order Information" for details of silk screen.

Description

The SCM1201B is a driver integrated with MOSFETs for the primary side of a push-pull power. The chip can function at the low input voltage of 3V, and will not be damaged under the high input voltage of 9V in one second. The device contains, two drive systems and two power MOSFET, and each drive system decides circuit's direction of one primary winding. Each drive system includes one power NMOSFET. Two drive systems operate in turns to achieve push-pull drive. Two power NMOSFETs are highly symmetrical in order to decrease the degree of magnetic biasing of push-pull topology. The SCM1201B is also integrated with three key technologies to improve reliability. The first one is soft start function, which limits the current of MOSFET to avoid the damage caused by the large current impact when turning on the power, and quantitatively guarantees the capacitive load in CC load mode. The second one is output over-current and short circuit protection. On the one hand, the SCM1201B distinguishes between the over-current protection and the short-circuit protection, which can control the short-circuit temperature rise while guarantee the capacitive load. On the other hand, the chip can adjust protection's threshold based on the input voltage and temperature to improve the consistency. The last one is over temperature protection, when the chip operates beyond the specified temperature, it will enters the dormancy state automatically. It will operate again when the temperature decreases to the set point.

Typical Application Circuit

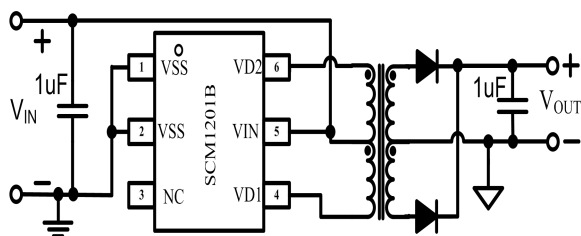

Function Curves

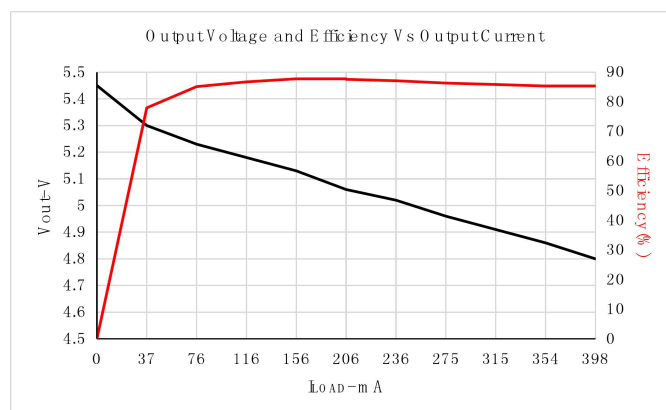

Contents

Features.....	1
Packaging.....	1
Application.....	1
Description.....	1
Typical Application Circuit.....	1
Function Curves.....	1
Pin Packaging.....	2
Inter Block Diagram.....	2
Pin Description.....	2
Absolute Maximum Ratings.....	2
Recommended Operating Condition.....	3

Electrical Characteristics.....	3
Typical Performance Curves.....	4
Parameter Measurement Information.....	4
Product Operation Mode.....	6
Extended Output Design.....	8
Application Circuit.....	8
Suggestions of Power Use.....	8
Order and Silk Screen Information.....	8
Package Information.....	9
Packing Information.....	10

Pin Packaging

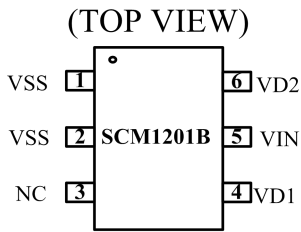

Inter Block Diagram

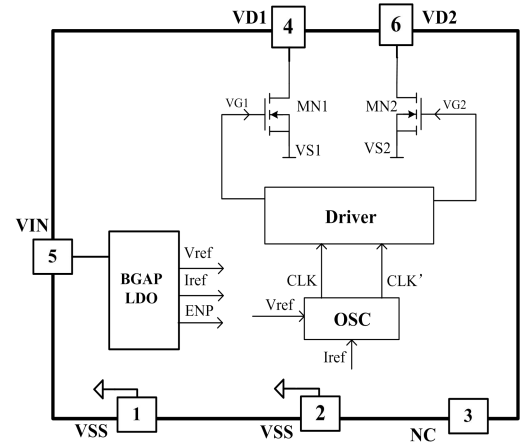

Pin Description

No.	Name	I/O	Description
1	VSS	P	Power ground
2	VSS	P	Device ground. Connect this pin to board ground.
3	NC	/	/
4	VD1	I	Built-in power LDMOSFET's drain.
5	VIN	P	Supply voltage input
6	VD2	I	Built-in power LDMOSFET's drain.

Absolute Maximum Ratings

General test conditions: Free-air, normal operating temperature range (unless otherwise specified).

Parameters		Min	Max	Unit
Input Voltage	V_{VIN}	-0.4	9	V
Drain Voltage of MOSFET	V_{VD1}/V_{VD2}	-0.7	26	V
Operation Junction Temperature Range	T_J	-40	150	°C
Storage Temperature	T_{STG}	-55	150	
Soldering Temperature (Allowable reflow soldering temperature of chip within 10 seconds)			260	
Moisture Sensitivity Level	MSL	MSL3		
Rated Value of ESD	Human body model (HBM)		6000	V
	Charged device model (CDM)		1000	

Note: if the value exceeds the stress value listed in the table's "Absolute Maximum Ratings", it may cause permanent damage to the components. If the product operates in the maximum rated condition for a long time, the reliability of the components may be affected. All voltage values take GND as basis reference. The current refers to the current between positive input and negative output of the specified terminal.

Recommended Operating Conditions

Unless otherwise specified, the following parameters are measured in the conditions of $V_{VIN}=5V$.

Parameters		Min	Max	Unit
Input Voltage	V_{VIN}	2.5	6	V
Drain Voltage of MOSFET	V_{VD1}/V_{VD2}	-0.7	18	V
Output Switching Current of Primary Winding	I_{D1}, I_{D2}	50	600	mA
Operation Junction Temperature	T_J	-40	150	°C

Electrical Characteristics

Unless otherwise specified, $V_{VIN}=5V$ and the environment temperature is 25°C.

Symbol	Corresponding Parameters	Test Conditions	Min	Typ	Max	Unit
Supply Section (VIN Pin)						
V_{VIN}	Operating voltage range		2.5		6	V
I_{RUN}	Operating Current of Chip	$V_{VIN}=5V$, No connection to VD1 and VD2		1.5	2	mA
I_{START}	I_{VIN} when V_{VIN} is in under-voltage lockout	$V_{VIN}=2V$		200		uA
V_{VIN_ON}	Start-up Voltage	V_{VIN} voltage increasing		2.5	2.7	V
V_{VIN_OFF}	Voltage when V_{VIN} is in under-voltage lockout	V_{VIN} voltage decreasing	2	2.2		V
V_{VIN_OVP}	V_{VIN} of over voltage	V_{VIN} voltage increasing		10.5		V
V_{OVP_OFF}	V_{VIN} of over recovery voltage	V_{VIN} voltage decreasing		6.2		V
T_{OTP}	Temperature of Over-temperature Protection	Environment temperature increasing		165		°C
T_{OTPH}	Return Difference of Over-temperature Protection	Environment temperature decreasing		141		°C
Drain Port of MOSFET (VD1/VD2 Pin)						
B_{VDSS}	Breakdown Voltage of MOS Transistor	$V_{GATE}=0V, I_{DS}=100uA$	26	35		V
R_{NDS_ON}	NMOS's On Resistance	$V_{VIN}=3V, T_J=25°C, I_{DS}=0.5A$		200	500	mΩ
		$V_{VIN}=5V, T_J=25°C, I_{DS}=0.5A$		150	400	
I_{SOFT}	Current of Soft Start	$V_{VIN}=3V, T_J=25°C, V_{VD1}=V_{VD2}=3V$		1000		mA
		$V_{VIN}=5V, T_J=25°C, V_{VD1}=V_{VD2}=3V$	600	800		
Switch Characteristics						
F_{OSC}	Operating Frequency	No connection to VD1 and VD2	195	220	245	kHz
T_{DEAD}	Maximum dead time	VD1, VD2 is in series with 200Ω/1W power resistance, $V_{VIN}=5V$		210		ns
	Minimum dead time	VD1, VD2 is in series with 50Ω/1W power resistance, $V_{VIN}=5V$		120		ns
T_{D_OSP}	Delay Time of Short Circuit Protection	$F_{OSC}=220kHz$	28	150		ms
T_{SLEEP}	Sleep Time of Short Circuit Protection	$F_{OSC}=220kHz$		1.5		s

Typical Performance Curves

Unless otherwise specified, the following typical characteristic curves are obtained in the conditions of $V_{IN}=5V$ and $T=25^{\circ}C$. Typical performance curves are obtained by testing the test circuit shown in Figure 5.

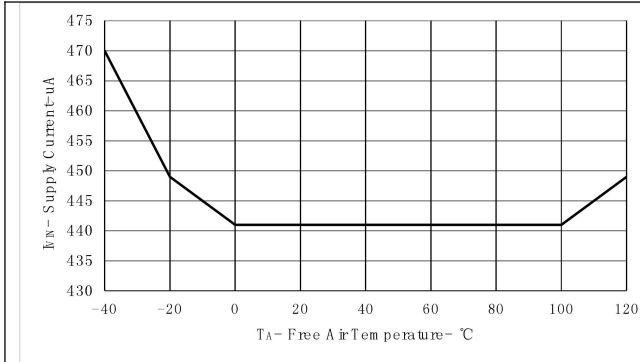

Figure 1 Average Supply Current of VIN VS Free-air Temperature

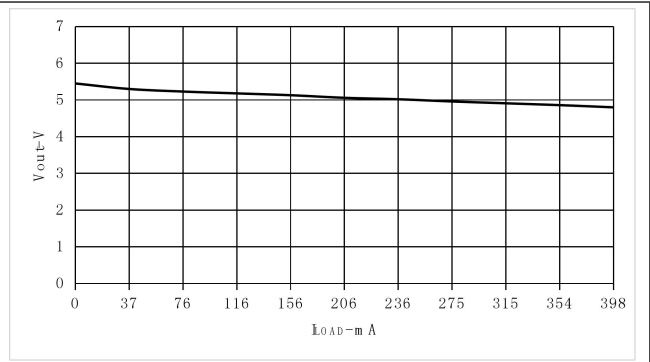

Figure 2 Output Voltage VS Load Current

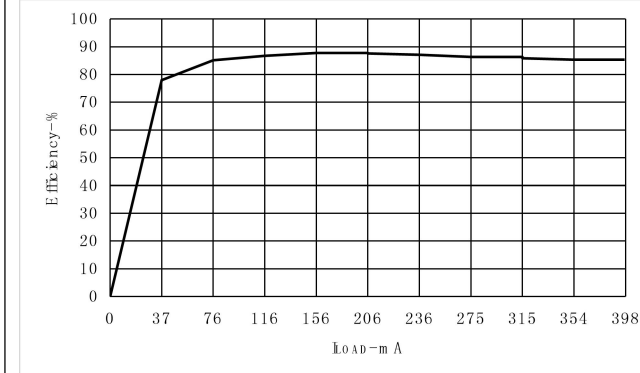

Figure 3 Efficiency VS Load Current

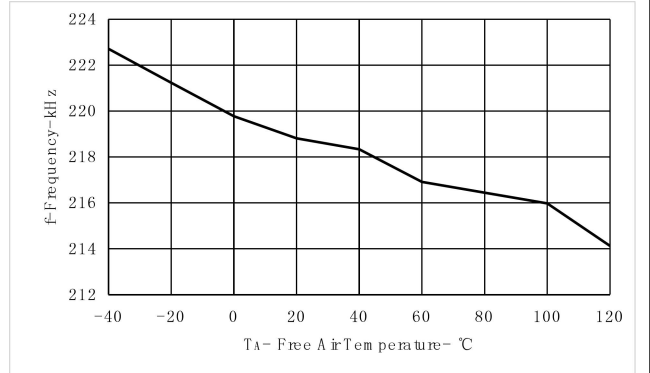

Figure 4 Switching Frequency of MOS Transistor VS Free-air Temperature

Parameter Measurement Information

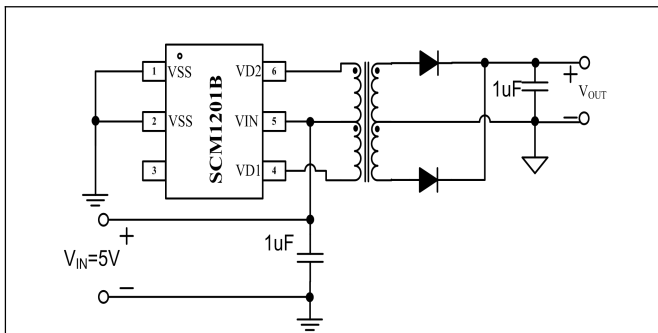

Figure 5 Schematic Diagram of Test Circuit for Function Curve

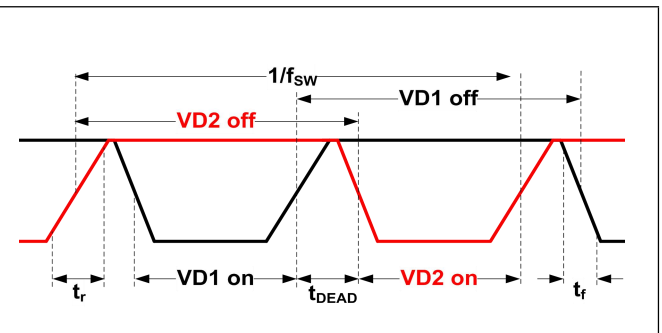

Figure 6 Circuit Sequence Diagram

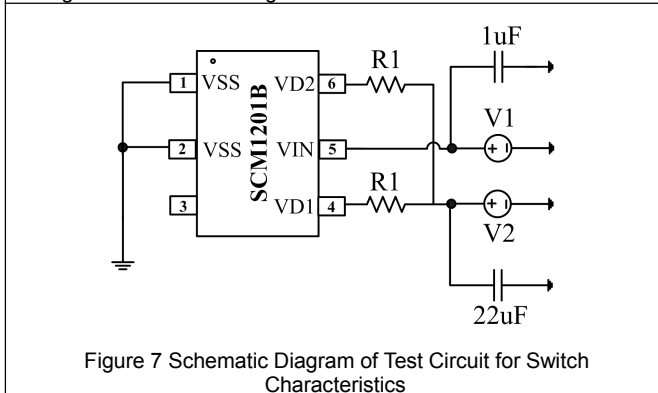
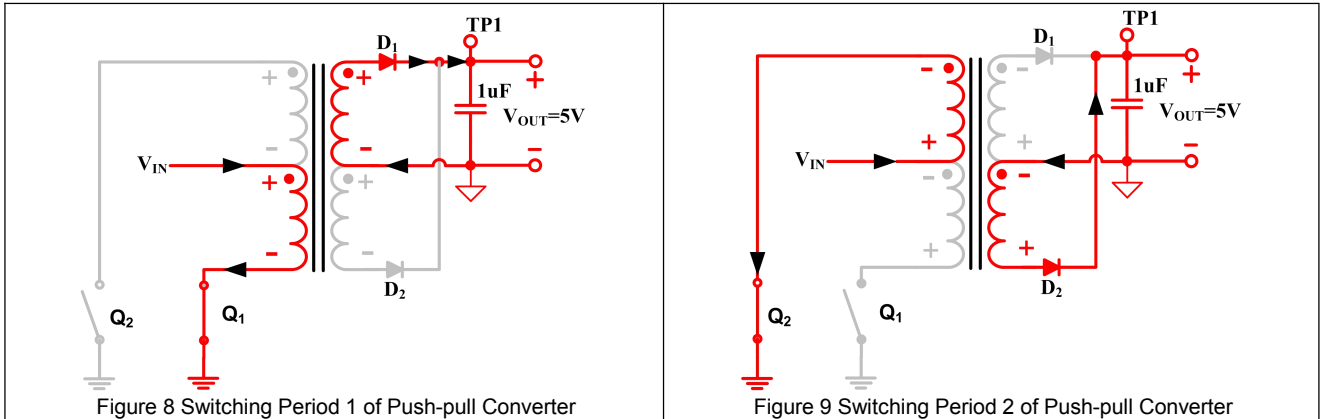

Figure 7 Schematic Diagram of Test Circuit for Switch Characteristics

(1) Push-pull Converter

As shown in Figure 8 and Figure 9, the push-pull converter is a transformer with center tap, which can achieve the transmission of energy from the primary winding to secondary winding.



The drive waveform of drains VD1 and VD2 of two MOSFETs Q1 and Q2 are shown in Figure 6. Two MOS transistors are on alternatively and the times of the breakover periods of two transistors are equal, and there is a short period t_{BEM} between the two breakover periods that the two power transistors are not on. That is to say, the drive levels of two MOS transistors are quasi complementary in time sequence, that is the other transistor is off when one transistor is on, but there is a short period of dead time during the switch to prevent the backward current flow when two the transistors are not on simultaneously. As shown in red highlighted parts in Figure 8, when Q1 is on, input voltage V_{IN} drives a current which arrives at the reference ground through the lower half of primary winding of transformer and Q1, and at the same time, the induced electromotive force of side winding charges output capacitor through diode D1, similarly, as shown in Figure 9, when Q2 is on, the induced electromotive force charges output capacitor through diode D2. As continuously repeating the above process, the secondary winding of power converter obtain the needed power supply.

(2) Magnetization of Magnetic Core

Figure 10 is the ideal magnetization curve of push-pull converter. The vertical axis represents magnetic flux density B , and the horizontal axis represents magnetic field intensity H . When Q_1 is on, the magnetic flow is pushed to point A' from point A . Similarly, when Q_2 is on, the magnetic flow is then pulled back to point A from point A' . The magnetic flux density B is proportional to the product of voltage of primary winding V_{LP} and breakover time of MOS transistors t_{ON} , which can be described in the following formula:

$$B \approx V_{LP} \times t_{ON}$$

The volt-second product $V_{LP} \times t_{ON}$ defines the magnetization degree of each switching period. If the volt-second products in the above “push” and “pull” periods are not identical, a small direct current component may be generated to cause the deviation of magnetic flow. If balance cannot be restored, the deviation of magnetic flow will gradually increase in the each of the following switching period, making magnetic core become saturated gradually. The phenomenon of the deviation of magnetic flow is usually caused by the unequal on resistance or switching speed of two power components. Although the on resistance or switching speed of the two power components are approximately equal through integrating them into the same wafer with the help of high matching advantage of semiconductor integrated circuit technology, the manufacturing error still exists, causing the small deviation for the breakover time.

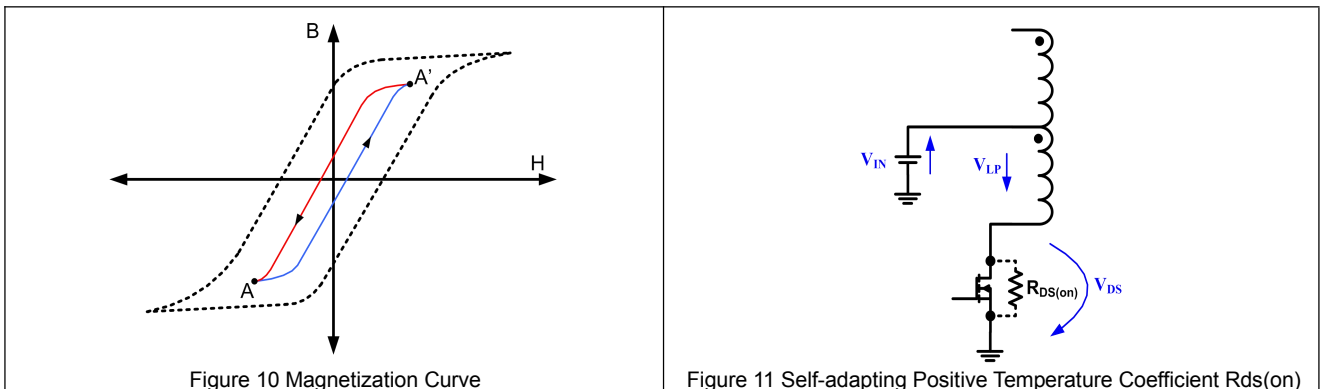

Fortunately, the breakover resistance $R_{DS(on)}$ of MOSFET has positive temperature coefficient, the SCM1201B has the self-correcting effect to restrain the imbalance of volt-second based on this feature. Under the condition that there is small deviation between the breakover time of two MOS transistors, the transistor which has longer breakover time t_{ON} generates more quantity of heat, and the temperature of the transistor rises to improve $R_{DS(on)}$, then in the breakover period when the load remains unchanged, the drain-source voltage of this transistor V_{DS} is relatively high, as shown in Figure 13, the voltage of primary winding V_{LP} conforms to the formula $V_{LP} = V_{IN} - V_{DS}$, thus the V_{LP} of the transistor which has larger t_{ON} will gradually decrease to make volt-second recover balance.

Product Operation Mode

SCM1201B has three operation modes, which respectively are start-up mode, operation mode and short-circuit protection mode.

In start-up mode, SCM1201B will first determine whether there is a short circuit phenomenon occurred in the system. The power MOSFET will be driven with limited current during this time. And the chip will choose short setting time.

When ruling out short circuit, SCM1201B provides sufficient charging time for output capacitor, to avoid the abnormal start caused by output short circuit which is incorrectly identified due to the excessive low voltage of output capacitor when it is just started, at the same time, the MOS transistor in start-up mode is always operating in current-limiting drive status which means that the drive voltage of MOS transistor in start is limited, thereby making the current flowing through MOS transistor restrained within the safe range of components, that is to restrain the output switching current of primary winding to I_{SOFT} to achieve the soft start of the system, thereby avoiding the over-current impact and the generation of excessive heat.

In operation mode, MOSFET is always in full drive status which means that the MOS transistor is operating in switching status and the breakover voltage is very low, which guarantee the efficiency of converter.

In short-circuit protection mode, it will stop driving the converter and enters dormancy state. to.. The product will not change to the start-up mode until it dissipates the heat generated in short-circuit mode .

The three operation modes can be freely switched. Only when there is abnormality of output short circuit, the product will repeatedly switch between the start-up mode and short mode, when the abnormality disappears, the product will automatically change to operation mode, all of which can fully guarantee the reliability of converter and have no influence on the performance of converter in normal operation.

Start-up Mode

The voltage of output capacitor is zero when the converter is just started, and the converter will firstly determine the system's state. The flow diagram is shown in Figure 12 . It can be described in the following form, Start → Drive the selected MOS transistor in current-limiting drive method → detect the switch-on voltages of MOS transistors(V_{VD1}, V_{VD2}) → judge whether the voltages (V_{VD1}, V_{VD2}) are more than the set value.

If (V_{VD1}, V_{VD2}) are more than the set value 1, then calculate the duration of over-voltage → judge whether the duration is more than T_{D_OSP1} (28ms, typ.). If yes, then the system turns into short circuit mode, if no, then the above process is repeated.

If (V_{VD1}, V_{VD2}) are less than the set value 1 and more than the set value 2, then the cumulative duration of exceeding set value 1 → judge whether the duration is more than T_{D_OSP2} (150ms, typ) . If not exceeded, enter start-up mode. If exceed, select the current limiting drive again and continue the cycle.

If (V_{VD1}, V_{VD2}) are not greater than the set value 1, then the system turns into operation mode.

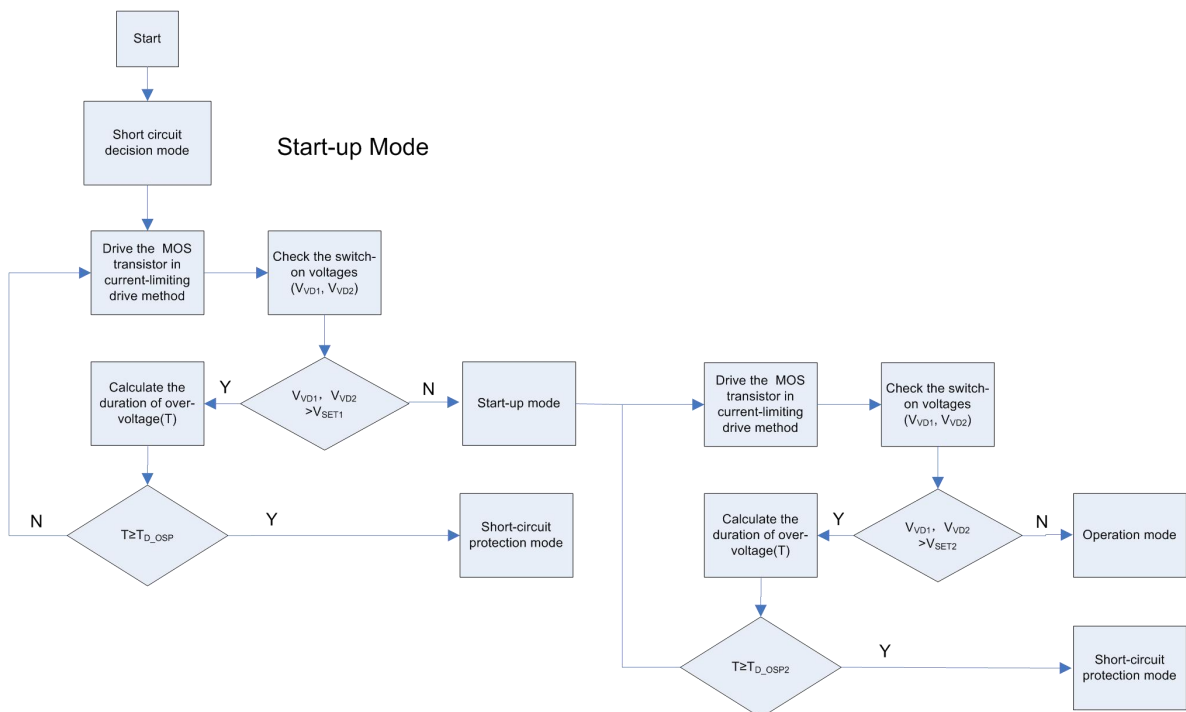

Figure 12 Flow Diagram of Start-up Mode

Operation Mode

If the output of converter has no short circuit, the voltage of output capacitor, in start-up mode, will gradually increase during the continuously circular charging. When the breakover voltage of MOS transistor is less than or equal to the set value, the converter will turn into operation mode. The flow

diagram is shown in Figure 15, that is, determine that the breakover voltage of MOS transistor is less than or equal to the set value → drive the selected MOS transistor with full drive → check the switch-on voltage of MOS transistors → judge whether the voltages (V_{VD1}, V_{VD2}) are more than the set value.

If the breakover voltage of MOS transistor is more than the set value, then the system goes into time-counting cycle of start-up mode, otherwise, the system turns back to the step “drive the selected MOS transistor with full drive”, and the above processes are repeated, which is the normal operation of the converter after the product is started. In the operation, MOS transistor is fully driven, that is the MOS transistor is operating in switching status and the on resistance is low, resulting in low energy consumption and high efficiency.

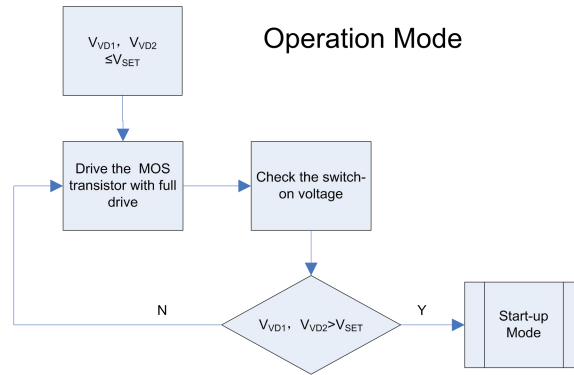

Figure 13 Flow Diagram of Operation Mode

Short-circuit Protection Mode

If the output of the converter is in short-circuit state, the chip will detect in start-up mode that the breakover voltage of MOS transistor is always more than the set value, then it will accumulate over-voltage time until the time exceeds T_{D_OSP} (150ms, typ.). At this time, SCM1212B will stop to drive the MOS transistor and begin to count the dormancy time of MOS transistor. When the time is counted to T_{SLEEP} (1500ms, typ.), the product resumes operation and turns into start-up mode.

The flow diagram of short-circuit protection mode is shown as Figure 14: determine the duration of over-voltage exceeding T_{D_OSP} → stop driving and begin to count time (dormancy mode) → finish counting time → turn back to start-up mode. We can see that if the converter is always in output short circuit status, it will operate in the short-circuit protection mode and start-up mode alternately.

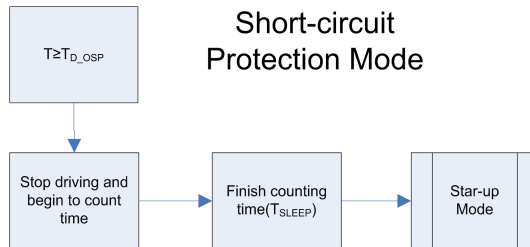

Figure 14 Flow Diagram of Short-circuit Protection Mode

Extended Output Design

SCM1201B is used to drive the push-pull circuit, which can make output voltage become higher.

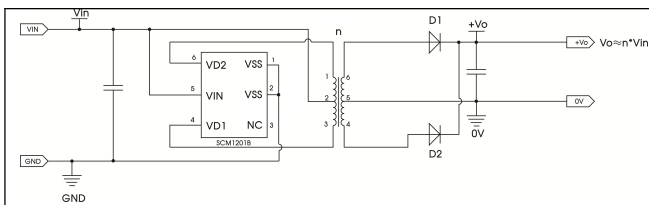

Figure 15 Extended Circuit I

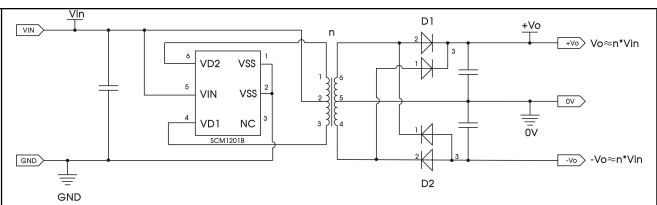

Figure 16 Extended Circuit II

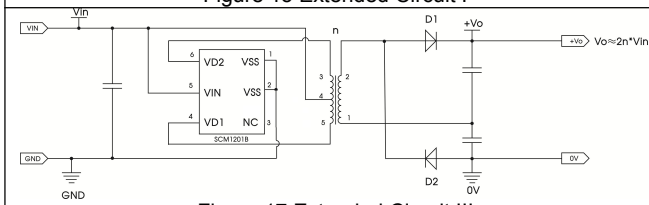

Figure 17 Extended Circuit III

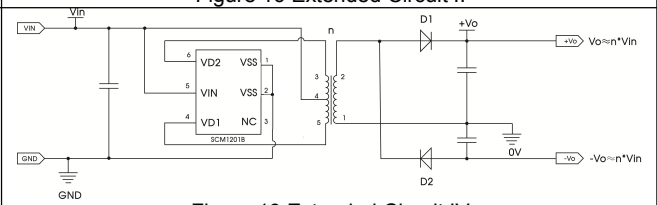

Figure 18 Extended Circuit IV

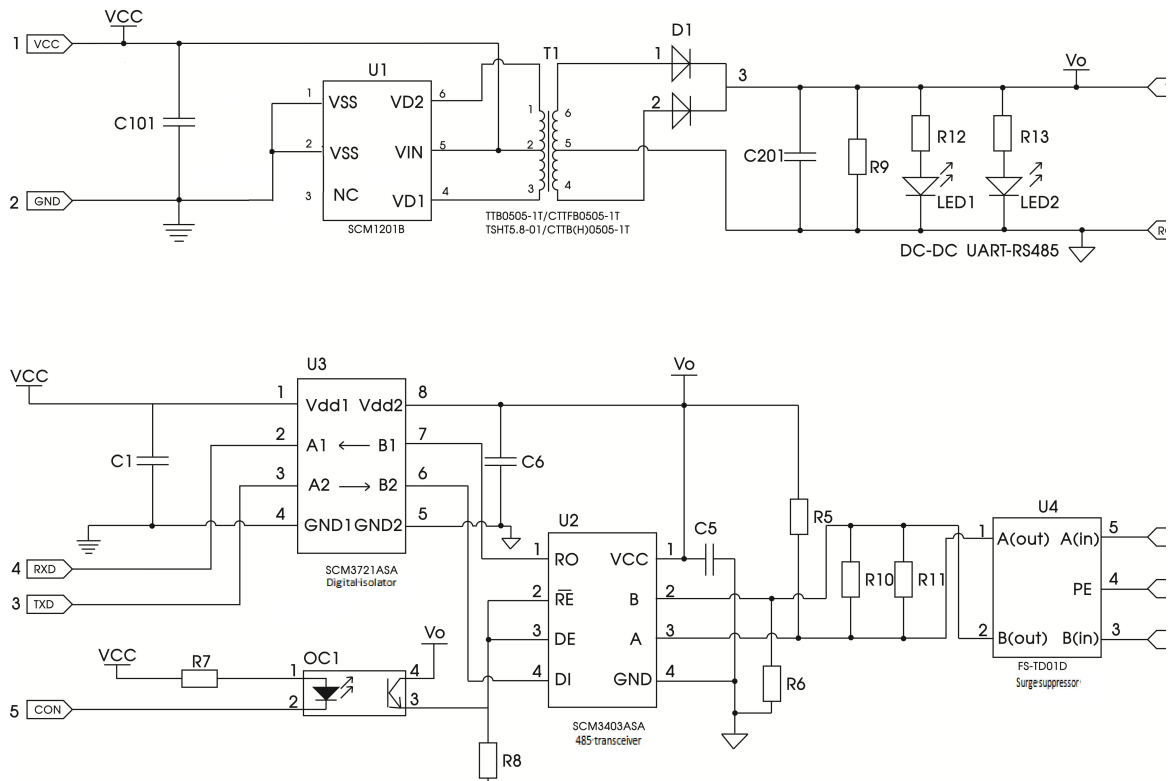

Figure 19 Application Circuit I

(1) Introduction of TTB05xx-1T Transformer

With the voltage of primary winding and secondary winding of 1650VDC, the allowable operating temperature of $-40^{\circ}\text{C} \sim +125^{\circ}\text{C}$ and the packaging size of 6.50 x 8.80 x 3.60mm, combined with design of our ICSCM1201BTA product, TTB05xx-1T transformer can be used for electrical isolation scenario which is applicable to 5VDC input and output power less than 1W, such as digital circuit, analog acquisition circuit and data exchange circuit. Please log in the official website of Mornsun and contact the salespeople to obtain the specific specification.

(2) Introduction of CTTF05xx-1T Transformer

CTTF05xx-1T transformer, with the packaging size of 12.50 x 8.70 x 5.90mm, is specially designed for use with IC. It is mainly used for the electrical isolation scenario which is applicable to 5VDC input and power less than 1W, such as digital circuit, analog acquisition circuit and data exchange circuit.

Suggested Use of Power Supply

If the input power is not stable enough, it is suggested to add 1uF capacitor in the first section of IC SCM1201B, if there is high requirement to EMI performance, it is suggested add capacitor and inductor in the first section of the module to filter noise, if there is high requirement to no-load voltage, please add resistor after the filtering capacitor of the module as dummy load. It is suggested that the connecting wire of pin 4 and pin 6 to the transformer is as short as possible.

Ordering information

Product Model	Packaging	Quantity of Pin	Silk Screen	Packing
SCM1201BTA	TSOT-23-6	6	1201YM	3K/tray

Description of Product Model

SCM1201XYZ:

- (1) SCM1201, product code.
- (2) X = A-Z, version code.
- (3) Y = T, packaging code, T: TSOT packaging.
- (4) Z = C, I, A, M, code of temperature range C: $0^{\circ}\text{C} \sim 70^{\circ}\text{C}$, I: $-40^{\circ}\text{C} \sim 85^{\circ}\text{C}$, A: $-40^{\circ}\text{C} \sim 125^{\circ}\text{C}$, M: $-55^{\circ}\text{C} \sim 125^{\circ}\text{C}$.
- (5) YM: Date code for product traceability; Y = code for production year; M = code for production month.

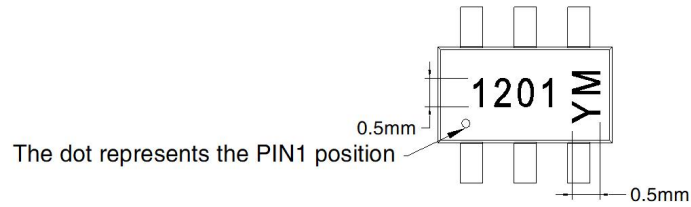

Note:

- 1、Typeface: Arial;
- 2、Character size:
Height: 0.5mm, Spacing: 0.1mm

Package Information

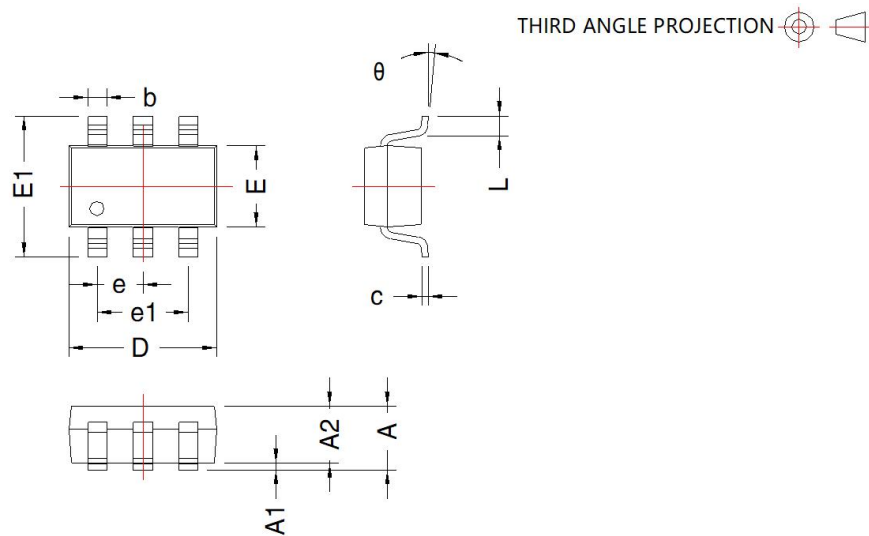

TSOT23-6				
Mark	Dimension(mm)		Dimension(inch)	
	Min	Max	Min	Max
A	—	0.90	—	0.035
A1	0	0.10	0	0.004
A2	0.70	0.80	0.028	0.031
D	2.80	3.00	0.110	0.118
E	1.50	1.70	0.059	0.067
E1	2.60	3.00	0.102	0.118
L	0.25	0.55	0.010	0.022
b	0.30	0.50	0.012	0.02
e	0.95 BSC		0.037 BSC	
e1	1.80	2.00	0.071	0.079
c	0.08	0.20	0.003	0.008
θ	0°	8°	0°	8°

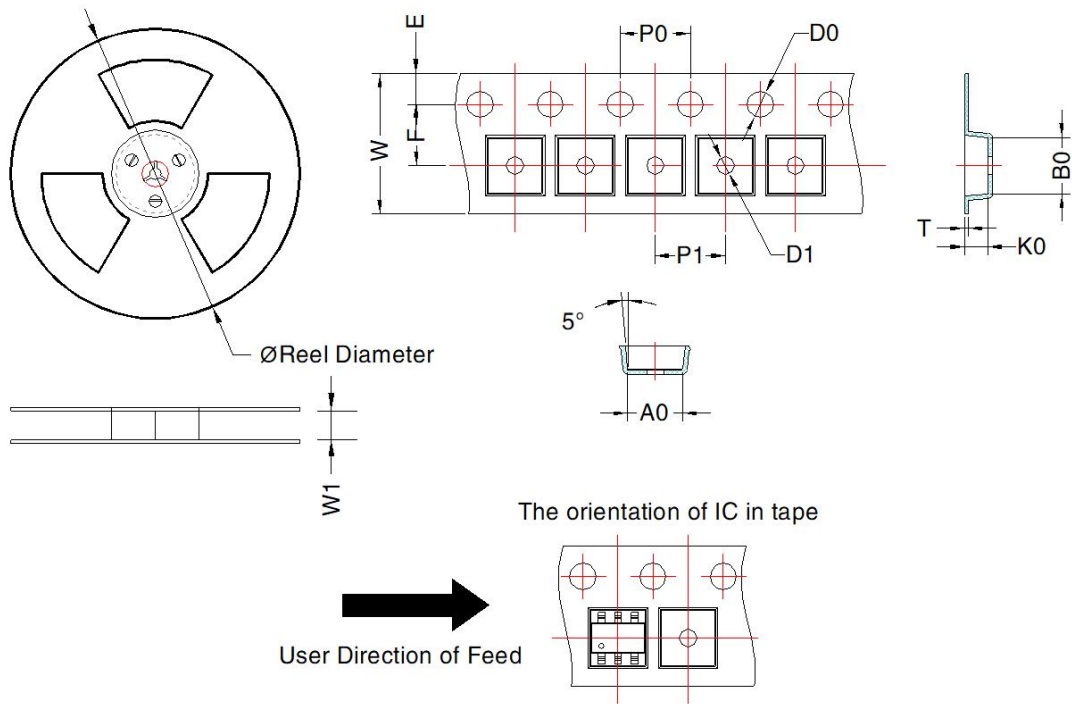

Device	Package Type	MPQ	Reel Diameter (mm)	Reel Width W1 (mm)	A0 (mm)	B0 (mm)	K0 (mm)	T (mm)	W (mm)	E (mm)	F (mm)	P1 (mm)	P0 (mm)	D0 (mm)	D1 (mm)
SCM1201BTA	TSOT23-6	3000	180.0	8.5	3.17 ± 0.1	3.23 ± 0.1	1.37 ± 0.1	0.25 ± 0.03	8.0 ± 0.3	1.75 ± 0.1	3.5 ± 0.1	4 ± 0.1	4 ± 0.1	1.5 ± 0.1	1.0 ± 0.1

Note: The minimum order quantity is the minimum packing quantity, and the order quantity shall be an integral multiple of MPQ.

Mornsun Guangzhou Science & Technology Co.,Ltd.

Address: No.5,Kehui St.1,Kehui Development Center,Science Ave.,Guangzhou Science City,huangpu District,Guangzhou,P.R.China

Tel: 400-1080-300

Fax: 86-20-38601272

Email: info@mornsun.cn