

DC/DC Converter

PV15-29BxxR3 Series

15W isolated DC-DC converter with ultra-wide, ultra-high 200 - 1500VDC input for renewable energy



CE Report EN62109-1 UK CA BS EN62109-1

RoHS



FEATURES

- Input voltage up to 1600VDC (Transient, duration: 10s)
- Ultra wide input voltage range: 200 - 1500VDC
- Industrial grade operating temperature: -40°C to +70°C
- High I/O Isolation voltage up to 4000VAC
- High efficiency, low ripple & noise
- Input under-voltage protection, input reverse polarity protection, output short circuit, over-current, over-voltage protection
- OVC II
- Reinforced insulation

PV15-29BxxR3 series is regulated DC-DC converters with an ultra-wide DC input of 200-1500VDC. The products feature high efficiency, high reliability, high insulation and high level of safety. This type of power supply is widely used in renewable energy industries such as photovoltaic, power generation, energy storage, inverters and high-voltage DC conversions. The converters provide multiple protection features and guarantee stable and safe operating environments even under abnormal working conditions. For extremely harsh EMC environment, we recommend using the application circuit show in Design Reference of this datasheet.

Selection Guide

Certification	Part No.*	Output Power (W)	Nominal Output Voltage and Current(Vo/Io)	Efficiency at 800VDC (%) Typ.	Capacitive Load (µF) Max. (Normal temperature full load)
EN	PV15-29B05R3	10	5V/2000mA	68	6000
	PV15-29B12R3	15	12V/1250mA	78	2000
	PV15-29B15R3		15V/1000mA	80	1200
	PV15-29B24R3		24V/625mA	83	470

Note: *Use suffix "A5" for chassis mounting and suffix "A6" for DIN-Rail mounting.

Input Specifications

Item	Operating Conditions	Min.	Typ.	Max.	Unit
Input Voltage Range		200	800	1500	VDC
	Transient (10s)	--	--	1600	
Input Current	200VDC	--	--	120	mA
	800VDC	--	--	30	
	1500VDC	--	--	16	
Inrush Current	200VDC	--	30	--	A
	1500VDC	--	90	--	
Under-voltage Protection		Lockout activation range: 130 - 175V Lockout deactivation range: 155 - 200V			
Input Reverse Polarity Protection		Available			
External Input Fuse Required		4A/1500VDC, required			
Hot Plug		Unavailable			

Output Specifications

Item	Operating Conditions	Min.	Typ.	Max.	Unit
Output Voltage Accuracy		--	±1.0	±1.5	%
Line Regulation	Full load	--	±0.25	±0.5	
Load Regulation	0% - 100% load	--	±0.25	±0.5	
Ripple & Noise*	20MHz bandwidth (peak-to-peak value)	--	--	150	mV
Temperature Coefficient		--	±0.02	±0.15	%/°C

Short Circuit Protection		Continuous, self-recovery				
Over-current Protection		≥120%Io, self-recovery				
Over-voltage Protection	PV15-29B05R3	≤8VDC				
	PV15-29B12R3	≤20VDC				
	PV15-29B15R3	≤20VDC				
	PV15-29B24R3	≤30VDC				
Minimum Load		0	--	--	%	
Start-up Delay Time**	200 - 1500VDC	--	--	2	s	
Hold-up Time	Room temperature, full load	800VDC input	--	20	--	ms
Note: *The "parallel cable" method is used for ripple and noise test, please refer to AC-DC Converter Application Notes for specific information; ** Full input voltage / output load range (The cooling-time between input power-off and power-on again is greater than 15s).						

General Specifications

Item	Operating Conditions		Min.	Typ.	Max.	Unit	
Isolation	Input - output	Electric Strength Test for 1min., leakage current <3mA	4000	--	--	VAC	
Operating Temperature			-40	--	+70	°C	
Storage Temperature			-40	--	+85		
Storage Humidity			--	--	95	%RH	
Soldering Temperature	Wave-soldering		260 ± 5°C; time: 5 - 10s				
	Manual-welding		360 ± 10°C; time: 3 - 5s				
Power Derating	-40°C to 0°C	200 - 300VDC	PV15-29B05/12/15R3	0.75	--	--	% / °C
	+50°C to +70°C	PV15-29BxxR3		1.5	--	--	
	2000m - 5000m			6.7	--	--	%/Km
Switching Frequency			--	65	--	kHz	
Altitude			--	--	5000	m	
Safety Standard			Design refer to UL1741 & EN62109-1, BS EN62109-1, CSA-C22.2 No.107.1-16				
MTBF	MIL-HDBK-217F@25°C		≥ 300,000 h				

Mechanical Specifications

Case Material	Black flame-retardant and heat-resistant plastic (UL94V-0)	
Dimensions	Horizontal package	89.00 x 63.50 x 25.00 mm
	A5 chassis mounting	135.00 x 70.00 x 33.50 mm
	A6 DIN-Rail mounting	135.00 x 70.00 x 39.00 mm
Weight	Horizontal package	200g (Typ.)
	A5 chassis mounting	280g (Typ.)
	A6 DIN-Rail mounting	350g (Typ.)
Cooling Method	Free air convection	

Electromagnetic Compatibility (EMC)

Emissions	CE	CISPR32/EN55032	CLASS A (See Fig. 2 for recommended circuit)	
	RE	CISPR32/EN55032	CLASS A (See Fig. 2 for recommended circuit)	
Immunity	ESD	IEC/EN61000-4-2	Contact ±6KV/Air ±8KV	Perf. Criteria A
	RS	IEC/EN61000-4-3	10V/m	Perf. Criteria B
	EFT	IEC/EN61000-4-4	±4KV	Perf. Criteria B
	Surge	IEC/EN61000-4-5	Line to line ±2KV	Perf. Criteria A
	CS	IEC/EN61000-4-6	10Vr.m.s	Perf. Criteria A

Product Characteristic Curve

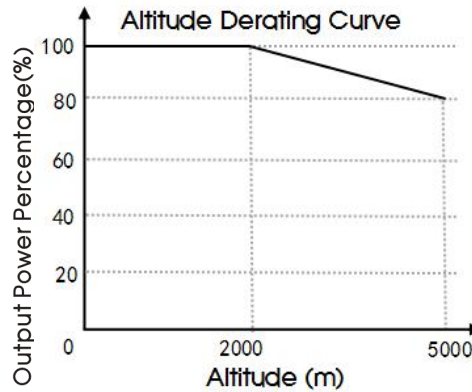
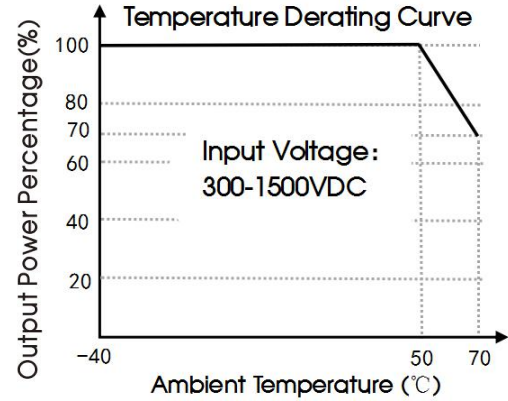
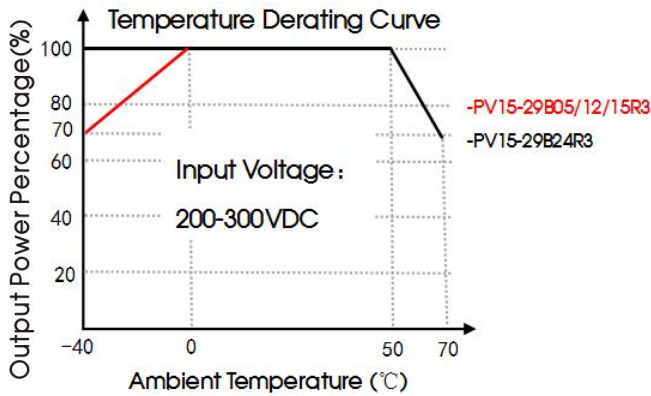

- Note:
- ① For operation of this converter series in an altitude between 2000 - 5000m above sea level, the output power must be derated as per the altitude derating curve;
 - ② This product is suitable for applications using natural free air convection; for applications in closed environment please consult Mornsun FAE.

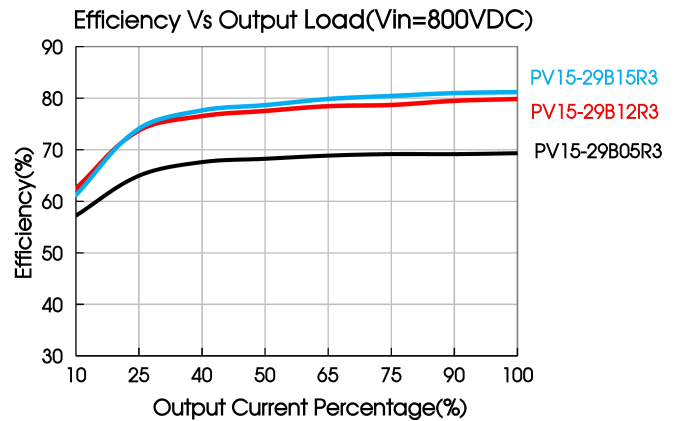
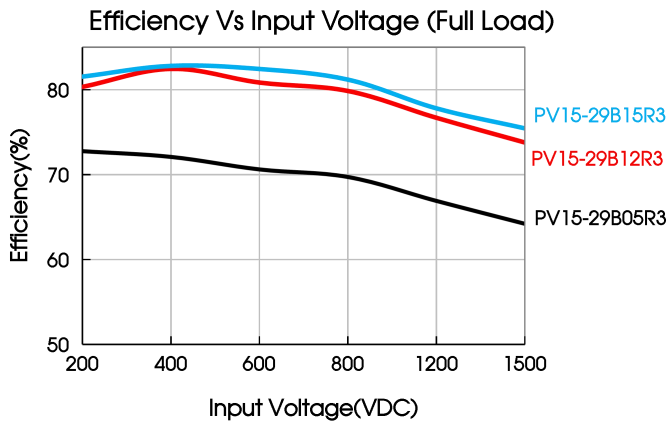

Design Reference

1. Typical application

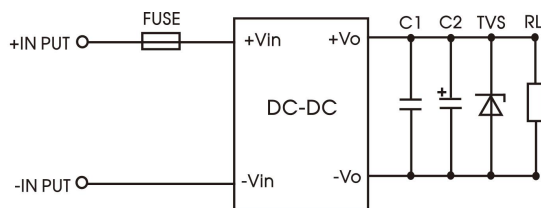

Fig. 1: Typical application circuit

Model	FUSE	C1(μF)	C2(μF)	TVS
PV15-29B05R3	4A/1500VDC, required	1μF/35V	120μF/35V	SMBJ7.0A
PV15-29B12R3			120μF/35V	SMBJ20A
PV15-29B15R3			120μF/35V	SMBJ20A
PV15-29B24R3			68μF/35V	SMBJ30A

Note on filter components:

We recommend using an electrolytic capacitor with high frequency and low ESR rating for C2 (refer to manufacture's datasheet). Choose a capacitor voltage rating with at least 20% margin, in other words not exceeding 80%. C1 is a ceramic capacitor, used to filter high-frequency noise. TVS is a recommended suppressor diode to protect the application in case of a converter failure.

2. EMC compliance recommended circuit

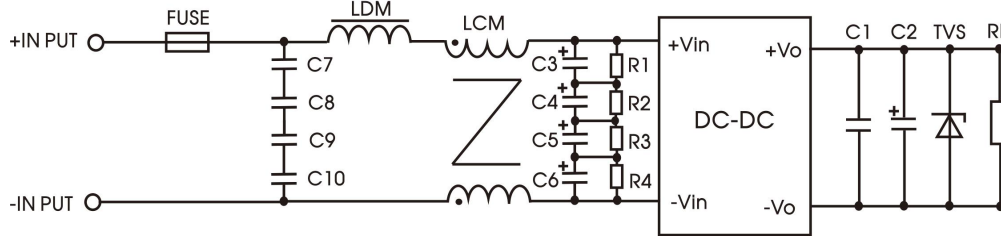



Fig 2: EMC application for higher compliance requirements (output parameters are show in Figure 1)

Component	Recommended Value
C7, C8, C9, C10	Safety capacitor 104K/275VAC
C3, C4, C5, C6	10uF/450VDC
R1, R2, R3, R4	1MΩ /2W
LDM	330uH/1A
LCM	7mH (recommended to use MORNSUN's FL2D-10-702B), three insulated wire
FUSE	4A/1500VDC, required

3. IMPORTANT SAFETY INSTRUCTIONS

SAVE THESE INSTRUCTIONS – This manual contains important instructions for Models PV15-29BxxR3 series that shall be followed during installation of the DC-DC converter.

- ① Additional protective devices, such as lightning protector need to be added if there is a transient pulse voltage greater than 6KV at the input of PV products in system applications.
- ② For symbol , it means circuit shall be connected to a dc circuit.

4. For additional information please refer to application notes on www.mornsun-power.com.

Dimensions and Recommended Layout

THIRD ANGLE PROJECTION 

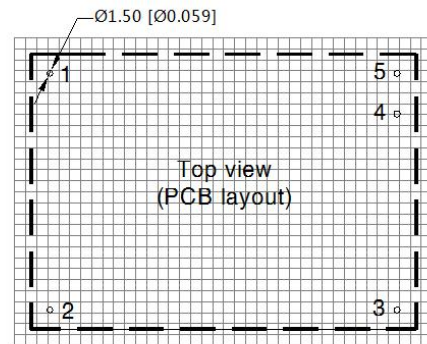
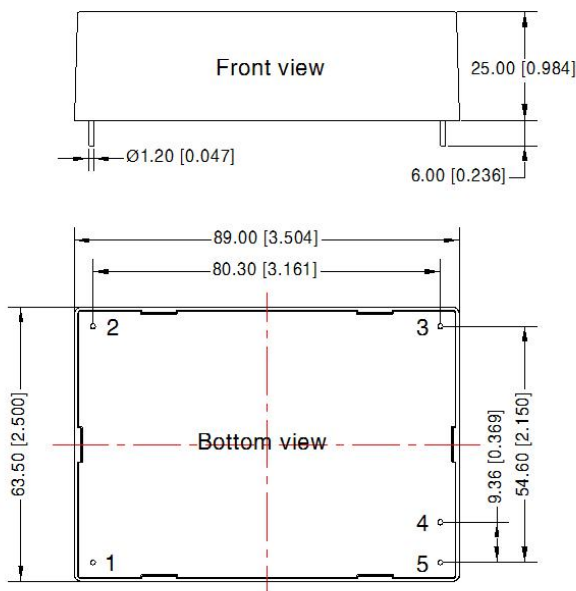

Note: Grid 2.54*2.54mm

Note:
Unit: mm[inch]
Pin diameter tolerances: ± 0.10 [± 0.004]
General tolerances: ± 0.50 [± 0.020]

Pin-Out	
Pin	Mark
1	-Vin
2	+Vin
3	NC
4	-Vo
5	+Vo

A5 Chassis Mounting Dimensions

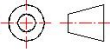
THIRD ANGLE PROJECTION 

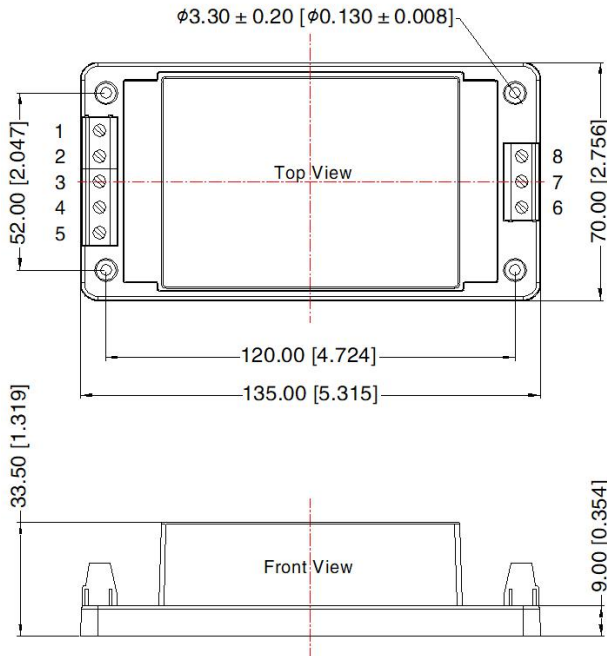

Pin-Out	
Pin	Mark
1	-Vin
2	NC
3	NC
4	NC
5	+Vin
6	NC
7	-Vo
8	+Vo

Note:
Unit: mm[inch]
Wire range: 24-12 AWG
Tightening torque: Max 0.4 N · m
General tolerances: ± 1.00 [± 0.040]

A6 Din-Rail Mounting Dimensions

THIRD ANGLE PROJECTION 

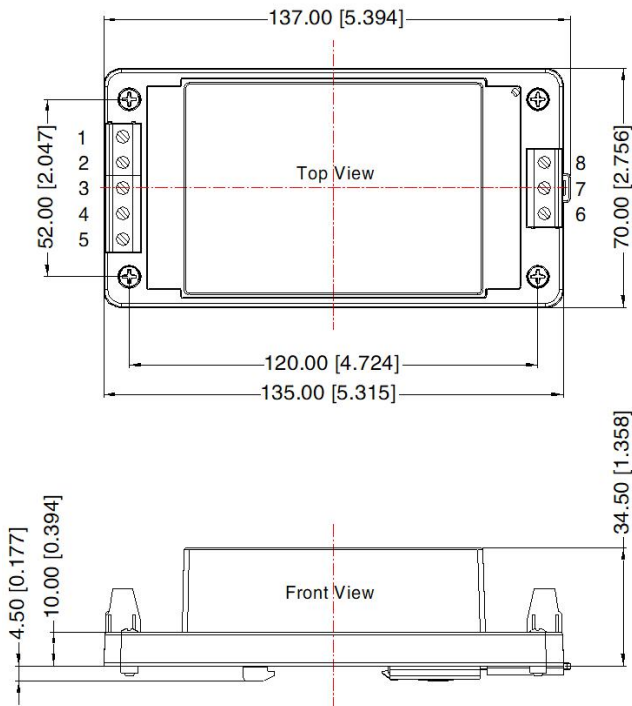

Pin-Out	
Pin	Mark
1	-Vin
2	NC
3	NC
4	NC
5	+Vin
6	NC
7	-Vo
8	+Vo

Note:
Unit: mm[inch]
Wire range: 24-12 AWG
Tightening torque: Max 0.4 N · m
Mounting rail: TS35, rail needs to connect safety ground
General tolerances: ± 1.00 [± 0.040]

 WARNING:

1. CAUTION: "To reduce the risk of fire, connect only to a circuit provided with 4 amperes maximum branch-circuit over-current protection in accordance with the National Electrical Code, ANSI/NFPA70."
2. WARNING: REPLACE ONLY WITH THE SAME RATINGS AND TYPE OF FUSE.
3. WARNING: SHOCK HAZARD. HORIZONTAL PACKAGE ONLY FOR MOUNTING IN A RACK OR ENCLOSURE FULLY ENCLOSING ALL LIVE PARTS.
4. DANGER — HIGH VOLTAGE.

AVERTISSEMENT:

1. Avertissement: Pour réduire le risque d'incendie, veuillez connecter uniquement à des circuits de dérivation avec protection contre les surintensités conformes au code électrique national ANSI/ NFPA 70.
2. AVERTISSEMENT : N'UTILISER QUE DES FUSIBLES DE MÊME CALIBRE ET DE MÊME TYPE QUE LE FUSIBLE D'ORIGINE.
3. AVERTISSEMENT: PAQUET HORIZONTAL RISQUE D'ÉLECTROCUTION. UNIQUEMENT POUR LE MONTAGE DANS UN RACK OU UN ENCEINTE ENFERMANT ENTièrement TOUTES LES PIÈCES SOUS TENSION.
4. DANGER : HAUTE TENSION.

Note:

1. For additional information on Product Packaging please refer to www.mornsun-power.com. Packaging bag number of Horizontal package: 58220021; the packaging bag number of A5/A6 package: 58220031;
2. Unless otherwise specified, A5/A6 products performance are consistent with Horizontal package products;
3. Unless otherwise specified, parameters in this datasheet were measured under the conditions of $T_a=25^{\circ}\text{C}$, humidity<75% with nominal input voltage and rated output load;
4. All index testing methods in this datasheet are based on our company corporate standards;
5. In order to improve the efficiency, there will be audible noise generated when working at input voltage higher than 1000 VDC, but it does not affect product performance and reliability;
6. The above are the performance indicators of the product models listed in this datasheet. Some indicators of non-standard models will exceed the above requirements. For details, please contact our technical staff;
7. We can provide product customization service;
8. Products are related to laws and regulations: see "Features" and "EMC";
9. Our products shall be classified according to ISO14001 and related environmental laws and regulations, and shall be handled by qualified units;
10. If the final product application is connected to a photovoltaic array, the array needs to be grounded and The voltage between the positive and negative poles of the product shall not be greater than 1500Vdc;
11. Input short circuit current Max. 4A.

Mornsun Guangzhou Science & Technology Co., Ltd.

Address: No.8 Nanyun 4th Road, Huangpu District, Guangzhou, China

Tel: 86-20-38601850

Fax: 86-20-38601272

E-mail: info@mornsun.cn

www.mornsun-power.com