



FEATURES

- AC & HVDC wide input voltage range: 90 - 264VAC/180 - 320VDC
- Strong adaptability to AC power grids, with EMS level 4 protection
- Wide operating temperature range: -25°C to +55°C without derating
- Supports 1.5 times transient power for 100ms, meeting the demands of sudden computing power scenarios
- Supports N+M ≤ 4 intelligent redundancy, cold backup efficiency optimization and active current sharing
- Supports PMBus/I2C communication protocols Equipped with fault early warning and black box functions
- Multiple protection mechanisms including overcurrent, short circuit, overvoltage, undervoltage, overtemperature and fan failure
- Full stack domesticization, safe and controllable
- Complies with CRPS 2.2 standard, 80 PLUS Platinum energy efficiency
- Safety according to UL/EN/IEC62368, IEC62368
- 5 years warranty

LMS800-P12BG product is the server power supply provided by Mornsun for customers. It supports AC & HVDC wide voltage range input, hot-plug available and parallel using requirements. It features high efficiency, intelligent backup function, anti-backflow, remote compensation. With PMBus / I2C communication function, it can support online monitoring of input / output voltage / current / power, with fault warning, black box and other functions. EMC and safety specifications meet the standards of UL/EN/IEC62368 and GB4943.

Selection Guide*

Certification	Part No.	Fan Operation Type	Output Power (W)	Nominal Output Voltage		Main Load		Auxiliary Load	Max. Capacitive Load (μF)	
				Main Circuit	Auxiliary Circuit	Min.	Max.	Typ.	Main Circuit	Auxiliary Circuit
--	LMS800-P12BG	Forward airflow, from DC to AC	800W	12.2VDC	12.0VDC	1A	65A	3.0A	50000	3000

Note: 1. *The product picture is for reference only. For details, please refer to the actual product.

Input Specifications

Item	Operating Conditions		Min.	Typ.	Max.	Unit	
Input Voltage Range	AC input		90	--	264	VAC	
	DC input		180	--	320	VDC	
Input Voltage Frequency	AC input		47	--	63	Hz	
AC input overvoltage	Protection voltage		300	--	320	VAC	
	Recovery voltage		290	--	315		
DC input overvoltage	Protection voltage		336	--	350	VDC	
	Recovery voltage		320	--	335		
Efficiency	TA=25°C, without Fan	Vin: 230VAC/50Hz	10% load	--	89	--	%
			20% load	--	94	--	
			50% load	--	94	--	
			100% load	--	91	--	
		Vin: 115VAC/60Hz	10% load	--	87	--	
			20% load	--	90	--	
		50% load	--	92	--		

			100% load	--	89	--	
Input Current	Vin=100Vac/60Hz Pout=800W			--	--	10	A
	Vin=200Vac/50Hz Pout=800W			--	--	5	
Inrush Current	Vin=264Vac/50Hz Pout=800W		Cold start	--	28	--	
Leakage Current to ground	Vin=264Vac fin=50Hz			--	--	1.75	mA
Power Factor	10%Imax<Io<20%Imax @ Vin=230Vac/50Hz			0.92	--	--	--
	20%Imax<Io<50%Imax @ Vin=230Vac/50Hz			0.96	--	--	
	50%Imax<Io<100%Imax @ Vin=230Vac/50Hz			0.99	--	--	
ITHD	5%Imax<Io<10%Imax @ Vin=230Vac/50Hz			--	--	20	%
	10%Imax<Io<20%Imax @ Vin=230Vac/50Hz			--	--	15	
	20%Imax<Io<40%Imax @ Vin=230Vac/50Hz			--	--	10	
	40%Imax<Io<50%Imax @ Vin=230Vac/50Hz			--	--	8	
	50%Imax<Io<100%Imax @ Vin=230Vac/50Hz			--	--	5	

Output Specifications

Item	Operating Conditions	Min.	Typ.	Max.	Unit	
Rated Output Voltage	+12.2V	12.1	12.2	12.3	V	
Steady State Output Voltage Range		11.8	12.2	12.6		
Output Ripple & Noise*		--	--	120	mV	
Output Current		1	--	65	A	
Current Sharing Accuracy (@160W<Pout<400W)		--	--	10	%	
Current Sharing Accuracy (@400W<Pout<=800W)		--	--	5		
Hold-up Time		12	--	--	ms	
Dynamic Load (60% dynamic load switching, 2.5A/us;+12.2V parallel 2200uF capacitor,the lowest load is 1A)		11.6	--	12.8	V	
Rated Output Voltage	+12VSB	11.4	12	12.6	V	
Steady State Output Voltage Range		11.4	12	12.6		
Output Ripple & Noise*		--	--	120	mV	
Output Current		0	--	3	A	
Hold-up Time		70	--	--	ms	
Dynamic Load (50% dynamic load switching, 0.5A/us;+12VSB parallel 1000uF capacitor,the lowest load is 0.05A)			11.4	--	12.8	V

Note: 1.*The "Tip and barrel method" is used for ripple and noise test, +12.2V output adds 2200uF capacitive load, and the coaxial cable is connected to the 10uF capacitor and 0.1uF ceramic capacitor in parallel;+12VSB output adds 270uF capacitive load, and the coaxial cable is connected to the 10uF capacitor and 0.1uF ceramic capacitor in parallel.For specific operation methods,please refer to the Server Power Test Specification.

Protective Characteristics

	Item	Min.	Typ.	Max.	Unit	Note	
	+12.2V Output	Over-current Alarm	68	75	78	A	Alarm after 20s,the main output will be turned off after 2s
Over-current Protection 1		90	95	98	The main output is turned off after 100ms		
Over-current Protection 2		102	105	115	The main output is turned off after 100us		
Short-circuit Protection		+12V output short-circuit protection mode is latching,+12VSB continuous output, reset by PSON#, AC power off and restart for recovery					
Over-voltage Protection		13.5	--	15.0	V	Latching, reset by PSON#, +12VSB continuous output	
Under-voltage Protection		9.5	--	11		Self-recover,+12VSB continuous output	
Over-temperature Alarm Point		56	--	--	°C	Over-temperature protection hysteresis greater than 3°C	
Over-temperature Protection Point		58	--	65			
Over-temperature Protection		55	--	--			

	Release					
	Fan-fault Protection	When the fan fails, turn off the output,automatic recovery after the failure is lifted				
+12VSB Output	Item	Min.	Typ.	Max.	Unit	Note
	Over-current Protection	4	4.5	5	A	Self-recover(The main output will be protected/self-recover together)
	Short-circuit Protection	Self-recover(The main output will be protected/self-recover together)				
	Over-voltage Protection	13.5	--	15	V	Self-recover(The main output will be protected/self-recover together)

LED Indicator Light

Power Status	Light Status
Power output normal	Green
All power supplies no AC input	Light off
AC input normal, only with +12VSB output or the product in sleep state in cold backup mode	The green light flashes at a frequency of 1Hz
One product no AC input, the other one with AC input	Orange
Product failure lead to output off, such as OVP, OCP, Fan Fault	Orange
Product in alarm status but with output on	The orange light flashes at a frequency of 1Hz
Product enters Always-Standby mode	The green light flashes at a frequency of 2Hz

Data Online Reading and Monitoring

Item	Accuracy Range		
Output Load	<10%	10% -30%	30% -100%
Input Voltage	±3%	±3%	±3%
Input Current	NA	±5% or ±0.5A	±5% or ±0.5A
Input Power	NA	±5% or 12W	±3%
Output Voltage	±5%	±3%	±3%
Output Current	NA	±5%	±5%
Output Power	NA	±5%	±5%

Timing Definition

Item	Description	Min.	Max.	Unit
Tvout_rise	Time for +12.2V output to rise from 0 to 10.8V	5	70	ms
	Time for +12VSB output to rise from 0 to 10.8V	1	25	
Tsb_on_delay	Time from AC power on to +12VSB output reaching at 10.8V	--	1500	
Tac_on_delay	Time from AC power on to +12.2V output reaching at 10.8V	--	3000	
Tvout_holdup	Time from AC power off to +12.2V output reaching at 10.8V	11	--	
Tpwok_holdup	Time from AC power off to PWOK signal decreasing	11	--	
Tpson_on_delay	Time from high to low of PSON# signal to +12.2V output reaching at 10.8V	5	400	
Tpson off delay	Time from low to high of PSON# signal to +12.2V output began to fall	--	10	
Tpson_pwok	Time from low to high of PSON# signal to PWOK signal becoming low-level	--	5	
Tpwok_on	Time from +12.2V output reaching at 10.8V to PWOK signal becoming high-level	100	500	
Tpwok_off	Time from PWOK signal becoming low-level to +12.2V output dropping to 10.8V	1	--	
Tpwok_low	Time from PWOK signal becoming low-level to when the PWOK signal increases through the PSON# switch or AC restart	100	--	
Tsb_vout	Time from +12VSB output reaching at 10.8V to +12.2V output reaching at 10.8V	50	1000	
T12VSB_holdup	Time from AC power off to +12VSB output voltage dropping to 10.8V	70	--	
Tvingood_de-asserted	Time from the input voltage dropped to 0V to VIN_GOOD signal becoming low-level	--	4	

Timing Diagram

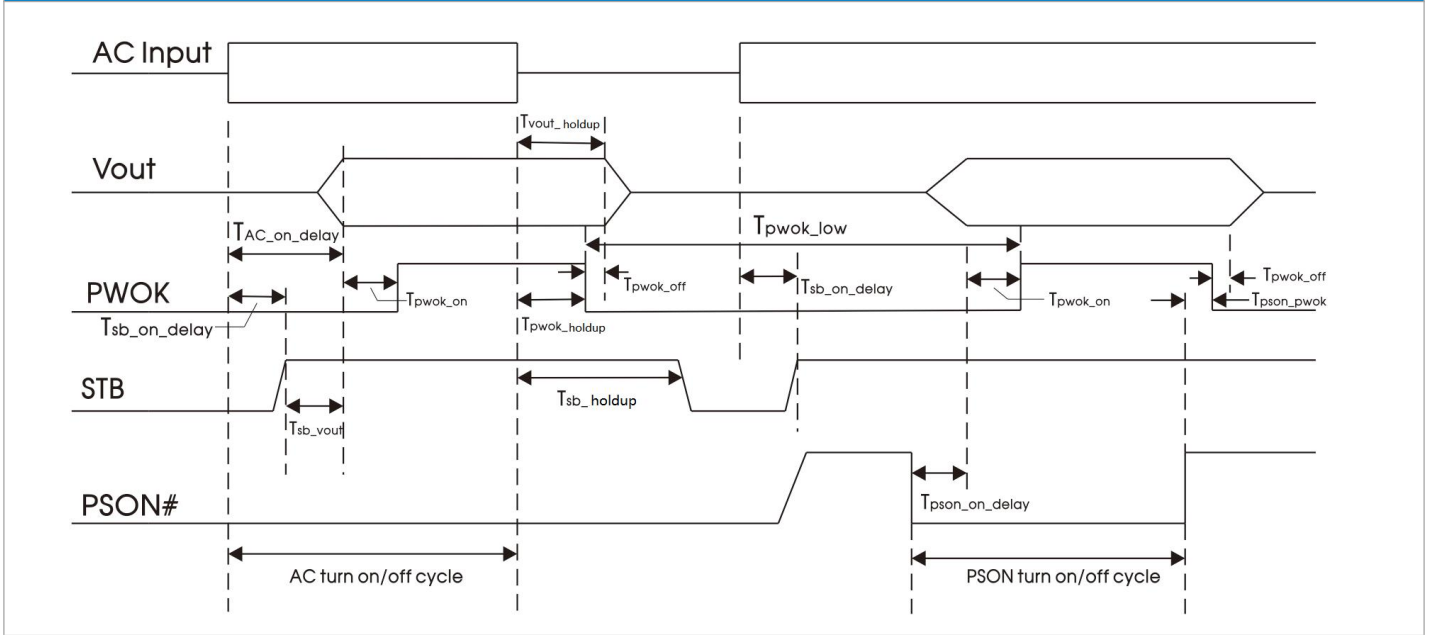

General Specifications

Item	Operating Conditions		Min.	Typ.	Max.	Unit	
Isolation Test	Input - ⊕	Electric strength test for 1min., leakage current < 5mA	1500	--	--	VAC	
	Input - Output*	Electric strength test for 1min., leakage current < 5mA	3000	--	--		
Insulation Resistance	Input - ⊕*	Ambient temperature: 25 ± 5°C Relative humidity: < 95%RH, no condensation Test voltage: 500VDC	50	--	--	MΩ	
	Input - Output						
Operating Temperature			-25	--	55	°C	
Storage Temperature			-40	--	70		
Operating Humidity	Non-condensing		--	--	90	%RH	
Storage Humidity			--	--	95		
Operating Altitude	≥2000m, the working temperature is reduced by 1°C/300m		--	--	5000	m	
Storage Ambient Height	1. 0.5m/s ≤ speed ≤ 1m/s, the backplane voltage cannot exceed the dynamic specification of the power module during hot-plug process. 2. The main output adds 2200uF capacitive load, and the auxiliary output adds 1000uF capacitive load.		--	--	15200		
Hot-plug	1. 0.5m/s ≤ speed ≤ 1m/s, the backplane voltage cannot exceed the dynamic specification of the power module during hot-plug process. 2. Add 1000uF capacitive load at the output.		Vo	11.6	--	12.8	V
			VSB	11.4	--	12.8	
Safety Standards			Design refer to UL/EN/IEC62368-1, GB4943.1				
MTBF	Rated input, 100% load @ 25°C Evaluated by Telcordia SR-332		>500,000 h				
Communication Method	PMBus / I2C						
Warranty	5 years						
Note: 1.*Input-Output isolation voltage refer to PCBA only; 2.*The output ground is connected to ⊕.							

General Specifications

Case Material	Metal (SGCC)
Dimensions*	73.50mm x 185.00mm x 40.00/39.00mm (W x D x H)
Weight	800g (Typ.)
Cooling Method	Forced-air cooling

Fan Noise	25°C, the overall noise ≤ 68dB (measure at 1m)
Note: 1.*Product shell height 39mm, fan height 40mm.	

Electromagnetic Compatibility (EMC)

Emissions	CE	CISPR32/EN55032	CLASS A	
	RE	CISPR32/EN55032	CLASS A	
	Harmonic current	IEC/EN61000-3-2	CLASS A	
Immunity	ESD	IEC/EN61000-4-2	Contact ±8KV/Air ±15KV	perf. Criteria A
	RS	IEC/EN61000-4-3	10V/m	perf. Criteria A
	EFT	IEC/EN61000-4-4	Input port: ±2KV	perf. Criteria A
	Surge	IEC/EN61000-4-5	line to line ±2KV/line to ground ±4KV	perf. Criteria A
	CS	IEC/EN61000-4-6	3Vrms	perf. Criteria A
	Voltage dips, interruption	IEC/EN61000-4-11	1 cycle @ nominal voltage input	perf. Criteria A

Functional requirements of black box

General requirements of black box	<p>1. Record the alarm when the output is turned off and the input power is down, the alarm status and the time of the fault occur are stored, and the important physical quantities at the fault site are saved and queried, including not limited to input voltage, output voltage, output current, temperature, fan speed, etc. Use the circular storage method (the black box information is written on the current index number +1 in case of failure, and when the index number is "record 4", the next line is written to "record 0").</p> <p>2. Support the host to query fault records one by one.</p> <p>3. Support host timing. The host needs to send the system time (time according to the Unix standard) to the power module, and the send it again every 10 minutes for the time synchronization of the power module.</p>				
Storage and reading mechanism of black box records	<p>Described from the time dimension, it is divided into the following stages:</p> <p>1. Power-up initialization stage After powering on, read the historical fault of the EEPROM record into the cache.</p> <p>2. Fault site storage stage The upper computer timings the power time (10min/time), when the output is turned off, the enabling fault record mark writes all the fault scene data to the EEPROM to generate a fault record.</p> <p>3. Fault data reporting stage When the upper computer queries the alarm log, each time a single query is made, the lower computer takes the corresponding data from the EEPROM storage area and uploads it all to the upper computer.</p>				
Black box reading protocol	Command	Name of the command	Data reading type	Data bytes	Description of the order
	DCh	MFR_READ_BLACK_BOX	Block Read	237	Power supply black box query, Reading: multi-byte (fault record information, you need to write the fault index before reading, 0-4, 0 is the latest record. 4 is the earliest record)
	Dfh	MFR_BLACKBOX_CONFIG	Read/Write Byte	1	0:disable black box function 1:enable black box function
System timing mechanism in the black box	<p>The power module needs to be time synchronized through host:</p> <p>Product: -- Synchronization -- Time to send the power module every 10 minutes -- The time to send is in seconds</p> <p>Power supply:-- Time synchronization of accepting products -- Interrupt timing, every 1second, the counter is increased by 1, and the time unit is seconds</p> <p>The timing time (time according to the Unix standard) is the number of seconds relative to the base time. The delivery time under the host will be sent to the power supply from the number of seconds from the base time to the current time. The time read in the alarm log is the number of seconds from the base time of the alarm. If the host is not given time, the running time of the power supply will increase by seconds, and the power drop needs to be saved.</p>				
Black box data content	<p>The black box records the real-time physical quantity and state data of the scene. The storage content is divided into two parts: the head and the data department. Each record contains 38 bytes of data.</p>				

Gold-finger Definition

Output Terminal	Definition	Output Terminal	Definition
A1-A9	SGND	B1-B9	SGND
A10-A18	+12V	B10-B18	+12V

A19	PMBus_SDA	B19	A0
A20	PMBus_SCL	B20	A1
A21	PSON#	B21	+12VSB
A22	SMBAlert#	B22	SMART_ON
A23	+12V Return sense	B23	+12V_Sharebus#
A24	+12V Remote sense	B24	PRESENT#
A25	PWOK	B25	VIN_GOOD

Note: The product is equipped with a built-in cooling fan, Keep the air intake clear of Debris, If the environment cannot meet this requirement, a fanless model is recommended.

Dimensions and Recommended Layout

THIRD ANGLE PROJECTION 

AC-C14 Pin-Out		Picture
Pin	Mark	
1	AC(L)	
2	⊕	
3	AC(N)	

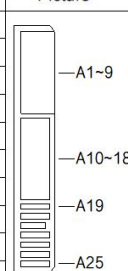
Goldfinger Pin-Out(Top)		Picture
Pin	Mark	
A1~9	SGND	
A10~18	+12.2V	
A19	PMBus_SDA	
A20	PMBus_SCL	
A21	PSON	
A22	SMBAlert#	
A23	+12V_Return sense	
A24	+12V_Remote sense	
A25	PWOK	

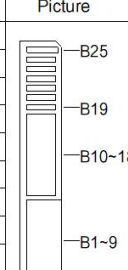
Goldfinger Pin-Out(Bottom)		Picture
Pin	Mark	
B1~9	SGND	
B10~18	+12.2V	
B19	A0	
B20	A1	
B21	+12VSB	
B22	SMART_ON	
B23	+12V_Sharebus#	
B24	PRESENT#	
B25	VIN_GOOD	

Note:
Unit: mm[inch]
General tolerances: ± 2[± 0.078]

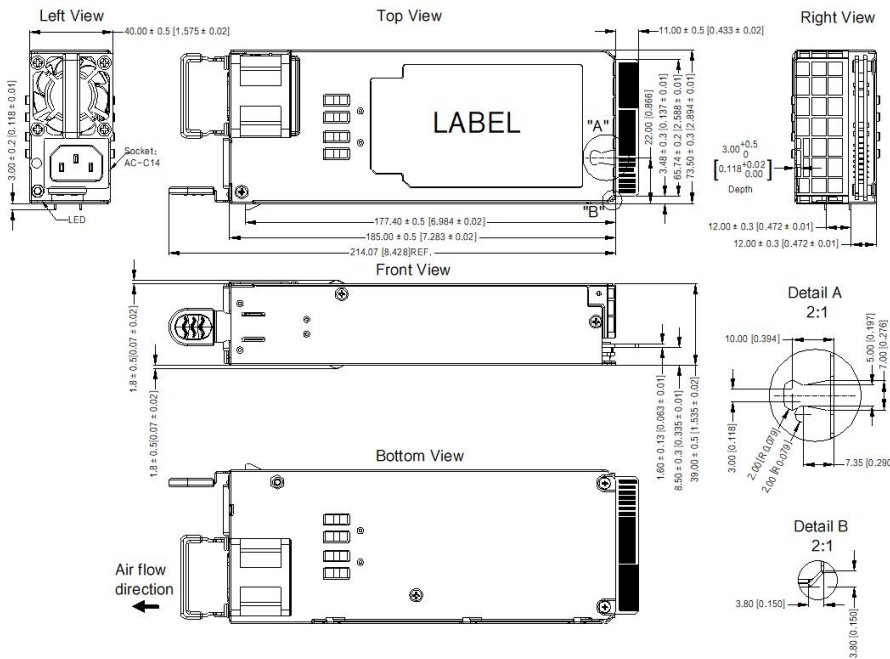

Recommended Tie Type

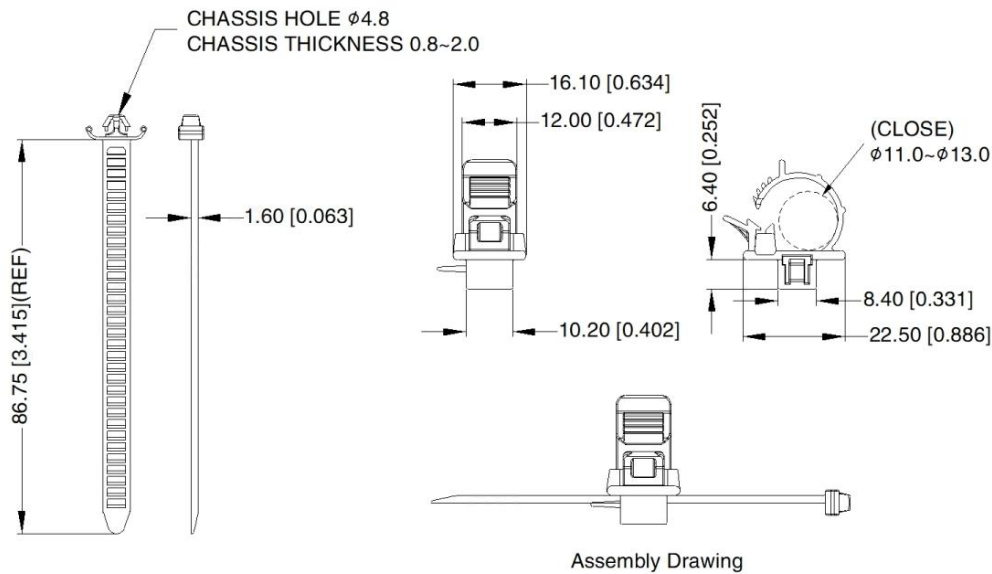

Note:

1. For additional information on Product Packaging please refer to www.mornsun-power.com. Packaging bag number: 58220607;
2. Unless otherwise specified, parameters in this datasheet were measured under the conditions of $T_a=25^{\circ}\text{C}$, humidity <75%RH with nominal input voltage and rated output load;
3. The room temperature derating of $1^{\circ}\text{C}/300\text{m}$ is needed for operating altitude greater than 2000m;
4. All index testing methods in this datasheet are based on our company corporate standards;
5. In order to improve the efficiency at high input voltage, there will be audible noise generated, but it does not affect product performance and reliability;
6. We can provide product customization service, please contact our technicians directly for specific information;
7. Products are related to laws and regulations: see "Features" and "EMC";
8. The out case needs to be connected to PE (⊕) of system when the terminal equipment in operating;
9. Our products shall be classified according to ISO14001 and related environmental laws and regulations, and shall be handled by qualified units;
10. The power supply is considered a component which will be installed into a terminal equipment. All EMC tests should be confirmed with the final equipment. Please consult our FAE for EMC test operation instructions.

Mornsun Guangzhou Science & Technology Co., Ltd.

Address: No. 8 Nanyun 4th Road, Huangpu District, Guangzhou, China

Tel: 86-20-38601850

Fax: 86-20-38601272

E-mail: info@mornsun.cn

www.mornsun-power.com