

FEATURES



- Operating ambient temperature range: -5°C to +50°C
- Optional ≤800W module power supply
- Over-current / short-circuit / over-voltage protection
- ATX multiplexed output(cables are optional)
- Full stack domesticization, safe and controllable
- Safety according to UL/EN/IEC62368, GB4943
- 5 years warranty



LMS800-12B-2H-PDB/W is a CRPS frame power supply for the server, and supports module power hot swap. Its input module is compatible with CRPS server power supplies, and the output module converts the module output voltage into ATX multi-output, the product is safe and reliable, realize the domestic production of materials.

Selection Guide*

Certification	Part No.*	Rated input voltage	Fan Operation Type	Output Power *(W)	Output*	Output current*(A)		Max. Capacitive Load(μF)
						Min.	Max.	
-	LMS800-12B-2H-PDB LMS800-12B-2H-W	/	Forward airflow, from DC to AC	800	+12.2V	1	65	25000
					+5V	0.5	25	5000
					+3.3V	0.8	25	5000
					-12V	0	0.5	350
					+5VSB	0	3	350

Note: 1.*The combined output power of +5V and +3.3V shall not exceed 200W. The output power is determined by the module power supply;
 2.*The main output ports are include +12.2V,+5V,+3.3V and -12V.The Aux output port is +5VSB;
 3.*This product is a frame power supply unit and must be used with one of our three module power supply models: LMS800-P12B, LMS550-P12B, or LMS350-G12B;
 4.*When paired with the LMS800-P12B, LMS550-P12B and LMS350-G12B models: ① The rated currents of the main +12.2V path are 65A, 45A, and 29A respectively; ② The total rated output powers are 800W, 550W, and 350W respectively;
 5.*The model AMS800-2DB-2H-W is for the cable assembly, and the model AMS800-2DB-2H-PDB is for the single-frame power supply product;
 6.The 24-pin system end cable connector's pin 16 (PS-ON signal) must be short-circuited to pin 17 (GND) for the main circuit to have output; otherwise, there will be no output;
 7.Modular power supply with 1+1 redundancy; the total output power of the chassis power supply shall not exceed the rated power of the paired modular power supply;
 8.The product picture is for reference only. For details, please refer to the actual product.

Output Specifications

Output	Output voltage (V)							
	Min.	Typ.	Max.	Tolerance				
Steady State Output Voltage Range	+12.2V	11.60	12.20	12.80	±5%			
	+5V	4.75	5.00	5.25	±5%			
	+3.3V	3.14	3.30	3.47	±5%			
	-12V	-10.08	-12.00	-13.20	±10%			
	+5VSB	4.75	5.00	5.25	±5%			
Dynamic	Output	Output voltage (V)			Base load	Step Load	A/us)	Cap(μF)
		Min.	Typ.	Max.				
	+12.2V	10.98	--	13.42	2A~40%	60% Load	0.5	2200
	+5V	4.5	--	5.5	3A~70%	30% Load	0.25	2200
	+3.3V	2.97	--	3.63	3A~70%	30% Load	0.25	2200
	-12V	-10.08	--	-13.20	0~0.25A	0.25A	0.25	100
+5VSB	4.5	--	5.5	0~2A	1A	0.25	22	
Ripple & Noise*	Output	Max.						
	+12.2V	120mV						
	+5V	50mV						
	+3.3V	50mV						

	-12V	120mV			
	+5VSB	50mV			
Output current	Output	Output current (A)			Remark
		Min.	Typ.	Max.	
	+12.2V	1	--	65	The output current is determined by the module power supply provided +5V and +3.3V combined output power \leq 200W
	+5V	0.5	--	25	
	+3.3V	0.8	--	25	
	-12V	0	--	0.5	
+5VSB	0	--	3		
Hold-up Time	Main outputs			\geq 12ms	
Note: 1.*During dynamic testing, the defined cap load capacitor need s to be added; 2.*The "Tip and barrel method" is used for ripple and noise test, +3.3V and +5V outputs parallel 100uF electrolytic capacitor, -12V and 5VSB outputs parallel 68uF electrolytic capacitor,coaxial cable in parallel with 10uF electrolytic capacitor and 0.1uF ceramic capacitor, please refer to Server Power Test Specifications for specific information.					

Protective Characteristics*

Over-voltage protection*	Output	Over Voltage Protection (V)			Remark
		Min.	Typ.	Max.	
	+12.2V	--	--	--	It is determined by the power supply of the attached module Main outputs will shut down and latch off, +5VSB output is normal
	+5V	5.74	--	7	
	+3.3V	3.76	--	4.7	
	-12V	-13.3	--	-16.5	All outputs will shut down, self-recovery
+5VSB	5.74	--	7		
Over-current Protection*	Output	Over Current Protection (A)			Remark
		Min.	Typ.	Max.	
	+12.2V	--	--	--	It is determined by the power supply of the attached module. Main outputs will shut down and latch off, +5VSB output is normal
	+5V	33	--	55	
	+3.3V	33	--	45	All outputs will shut down, self-recovery
+5VSB	5.5	--	7.5		
Short-circuit Protection*	Output	Remark			
	+12V	It is determined by the power supply of the attached module			
	+5V	Main outputs will shut down and latch off, +5VSB output is normal			
	+3.3V				
	-12V	All outputs will shut down, self-recovery			
+5VSB					

Note:1.*The OCP, OVP and SCP of +12V are determined by the OCP, OVP and SCP of the module power supply .For details, refer to the module power supply specification;
 2.*The main road has experienced a protection lockout. It can be restarted by using the PS ON switch or by entering the restart command.

Buzzer Alarms*

	Module power supply Status	Module LED Status*	Buzzer*
1+0 or 0+1	No AC power	OFF	/
	PSU standby state AC present / Only +5VSB on (PSON is high or floating)	Blink Green	/
	Power supply failure lead to main output off (PSON is low)	Amber or Blink Green	/
	Power output normal	Green	/
1+1	Dual modules parallel, one module power output normal, another failure (PSON is low) .	Failure module: Amber Normal module: Green	Alarm
	Dual modules parallel, Power supply failure lead to main output off (PSON is low) .	Amber or Blink Green	/
	Dual modules parallel, turn on AC power of only one module to work (PSON is low) (first power on).	Without AC power: Amber With AC power: Green	Alarm
	Both modules power output normal.	Green	/

Note: 1.*The LED Indicator refers to the module power indicator adapted by our company, for reference;
2.*It is normal for the buzzer to ring briefly when main power on or power off;
3.*When the buzzer alarms, you can press the RESET switch to eliminate the alarm sound.

Timing

Item	Description	Min.	Max.	Unit
Tvout_rise	Time for Main output (except -12V) to rise from 0 to within regulation limits	1	70	ms
T-12V_rise	Time for -12V to rise from 0 to within regulation limits	--	25	ms
T5VSB_rise	Time for +5VSB to rise from 0 to within regulation limits	--	25	ms
Tsb_on_delay	Time from AC power on to +5VSB being within regulation limits	--	1500	ms
T ac_on_delay	Time from AC power on to Main output being within regulation limits	--	2500	ms
Tvout_holdup	Time from AC power off to +12.2V output reaching at 10.8V	12	--	ms
Tpwok_holdup	Time from AC power off to PWOK signal decreasing	11	--	ms
Tpson_on_delay	Time from high to low of PSON# signal to Main output voltages being within regulation limits.	5	470	ms
T pson_pwok	Time from low to high of PSON# signal to PWOK signal becoming low-level	--	65	ms
Tpwok_on	Delay from output voltages within regulation limits to PWOK becoming high-level at turn on	100	500	ms
T pwok_off	Time from PWOK signal becoming low-level to +12.2V output dropping to 10.8V	1	--	ms
Tpwok_low	Time from PWOK signal becoming low-level to when the PWOK signal increases through the PSON switch or AC restart	100	--	ms
Tsb_vout	Time from +5VSB being in regulation to Main output being in regulation	50	2000	ms

Note: The Tvout holdup specification is determined by the individual module, and specific conditions should be referred to the module specification document.

Timing Diagram

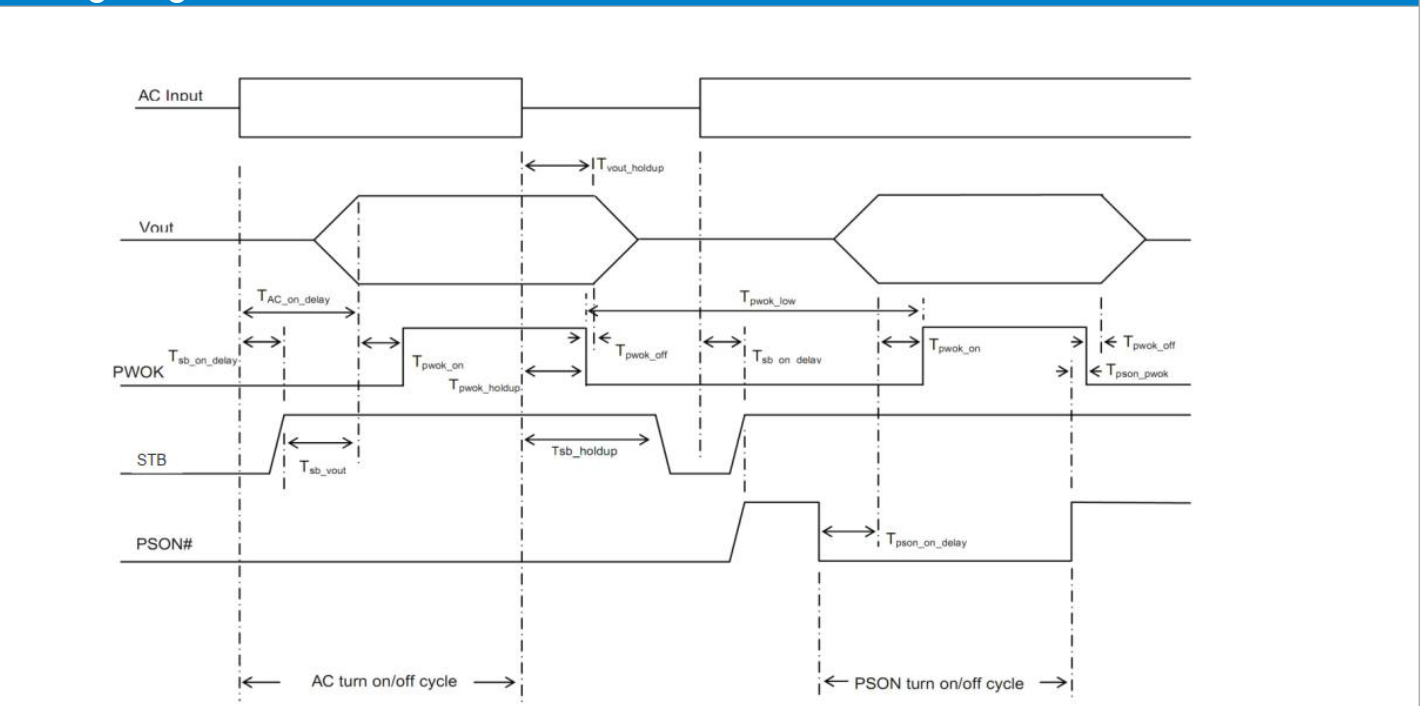

General Specifications

Item		Operating Conditions	Min.	Typ.	Max.	Unit
Isolation Test	Input - ⊕	Electric strength test for 1min., leakage current <5mA	1500	--	--	VAC
	Input - Output*	Electric strength test for 1min., leakage current <10mA	3000	--	--	
Insulation Resistance	Input - ⊕	Ambient temperature: 25 ± 5°C Relative humidity: < 95%RH, no condensation Test voltage: 500VDC	50	--	--	MΩ
	Input - Output					
Operating Temperature			-5	--	50	°C

Storage Temperature		-40	--	70	
Operating Humidity	Non-condensing	5	--	90	%RH
Storage Humidity		5	--	95	
Operating Altitude	≥2000m, the temperature derating is 1°C for every 300m.	--	--	5000	m
Storage Altitude		--	--	15200	
Hot swap	1. 0.5m/s≤speed≤1m/s, the backplane voltage cannot exceed the dynamic specification during hot-plug process. 2. Add dynamic cap load of at the output.	+12.2V	10.98	--	13.42
		+5V	4.5	--	5.5
		+3.3V	2.97	--	3.63
		-12V	-10.08	--	-13.20
		+5VSB	4.5	--	5.5
Safety Standards		Design refer to UL/EN/IEC62368-1, GB4943.1			
MTBF	Rated input, 100% efficiency load @ 25°C Evaluated by Telcordia SR-332	≥ 250,000 h			
Warranty	5 years				

Note: 1.*Input-Output isolation voltage refer to PCBA only.And all the output GND pins of the frame power supply are connected to the metal case,Ⓧ.

Mechanical Specifications

Case Material	Metal (SGCC)	
Dimensions*	77.00mm x 225.00mm x 84.00mm (W x D x H)	
Weight*	AMS800-2DB-2H-W	980 g (Typ.)
	AMS800-2DB-2H-PDB	575 g (Typ.)

Note: 1.*Product dimensions do not include out wires;
2.*Weight does not include module power supply.

Output terminal definitions

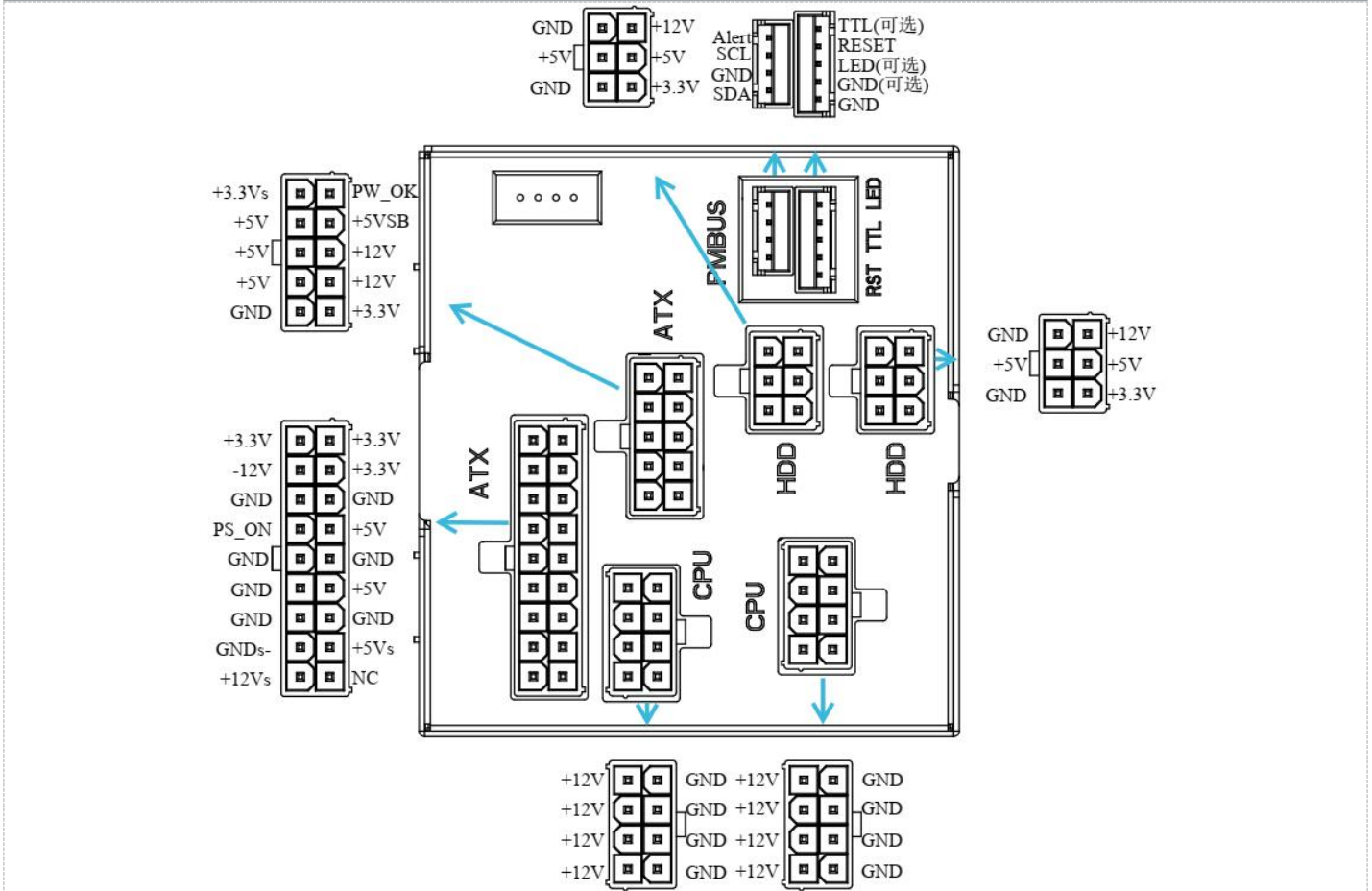

Output wire dimensions and definitions

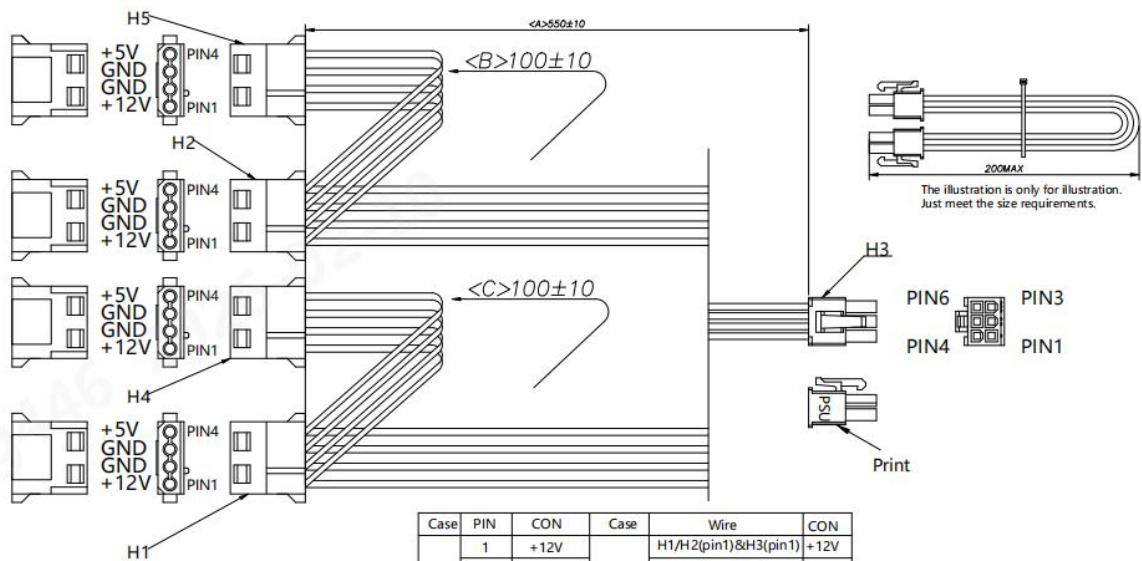

Table:

Case	PIN	CON	Case	Wire	CON
H1 H2	1	+12V	H3	H1/H2(pin1)&H3(pin1)	+12V
	2	GND		H1(pin4)&H3(pin2)	+5V
	3	GND		NC	
	4	+5V		H1(pin2&3)&H3(pin4)	GND
				H2(pin4)&H3(pin5)	+5V
				H2(pin2&3)&H3(pin6)	GND

Quantity: 1pcs

Technical Requirements:

1. The terminals are made of phosphor bronze.
2. The wire material is UL2468 18AWG with a temperature resistance of 80°C and a voltage rating of 300V.
3. The wire material number is PJA-072. It can be ordered as needed.

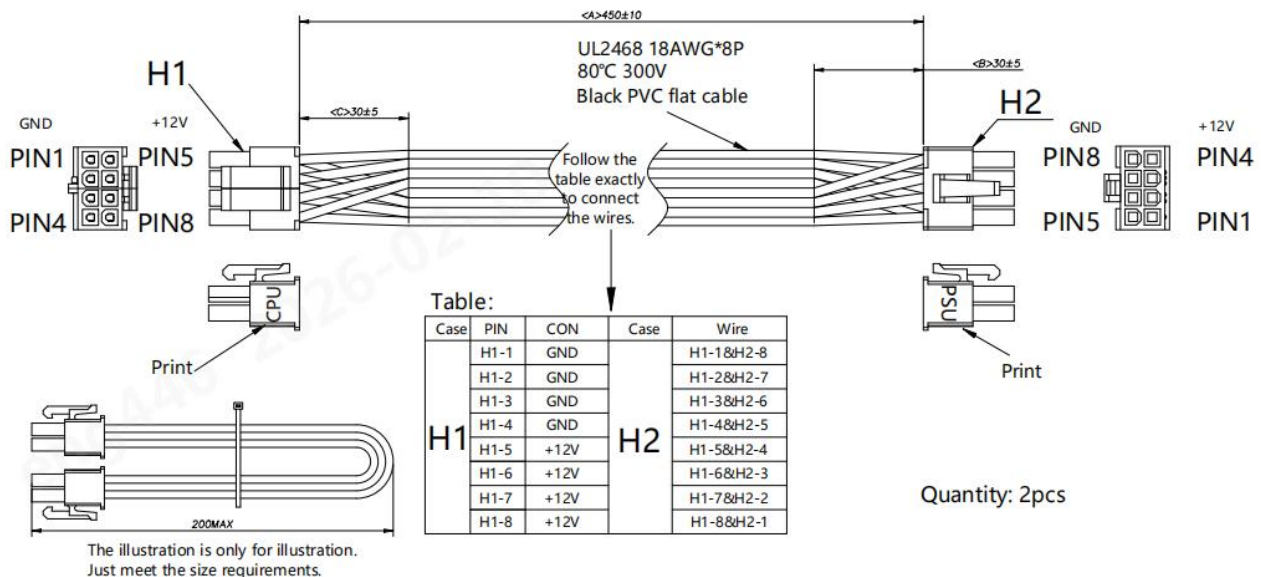

Table:

Case	PIN	CON	Case	Wire
H1	H1-1	GND	H2	H1-1&H2-8
	H1-2	GND		H1-2&H2-7
	H1-3	GND		H1-3&H2-6
	H1-4	GND		H1-4&H2-5
	H1-5	+12V		H1-5&H2-4
	H1-6	+12V		H1-6&H2-3
	H1-7	+12V		H1-7&H2-2
	H1-8	+12V		H1-8&H2-1

Quantity: 2pcs

Technical Requirements:

1. The terminals are made of phosphor bronze.
2. The wire material is UL2468 18AWG18P with a temperature resistance of 80°C and a voltage rating of 300V.
3. The wire material number is PJA-072. It can be ordered as needed.

Follow the table exactly to connect the wires.

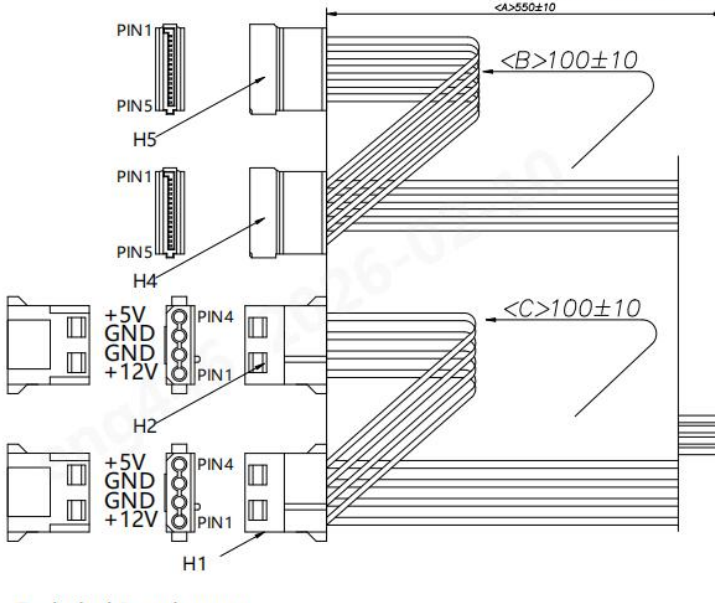
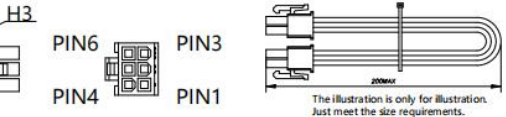

Table:

Case	PIN	CON	Case	PIN	CON	Wire
H1	1	+12V	H3	1	+12V	H1(pin1)+H4(PIN5)&H3(pin1)
	2	GND		2	+5V	H1(pin4)&H3(pin2)
H2	3	+3.3V		3	+3.3V	H4(pin1)&H3(pin3)
	4	+5V		4	GND	H1(pin2&3)&H3(pin4)
				5	+5V	H4(pin3)&H3(pin5)
				6	GND	H4(pin2&4)&H3(pin6)
H4	1	+3.3V				
H5	2	GND				
	3	+5V				
	4	GND				
	5	+12V				



Quantity: 1pcs

Technical Requirements:

1. The terminals are made of phosphor bronze.
2. The wire material is UL2468 18AWG with a temperature resistance of 80°C and a voltage rating of 300V.
3. The wire material number is PJA-072. It can be ordered as needed.

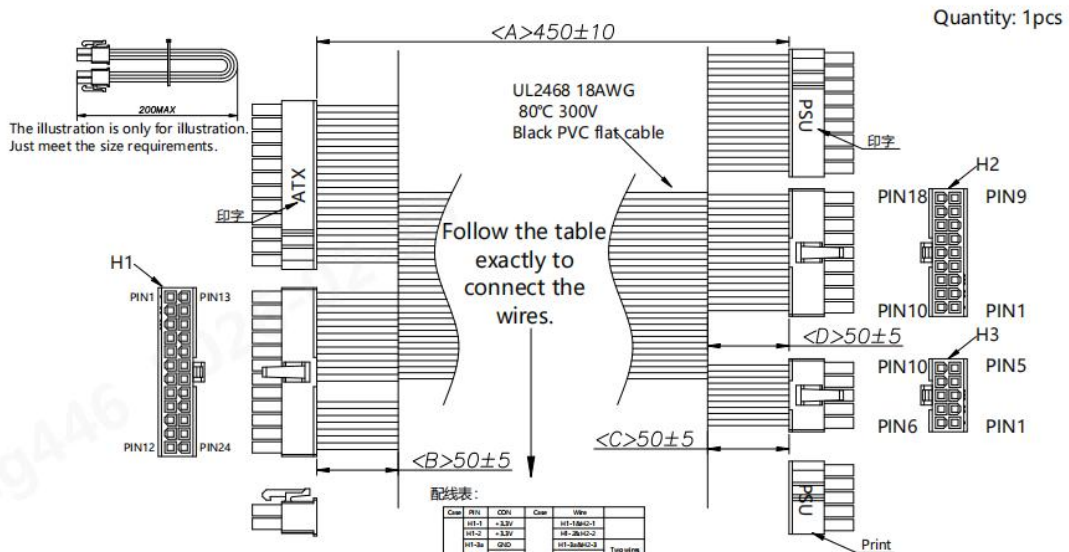

配线表:

Case	PIN	CON	Case	Wire
H1-1	+3.3V		H1-10A10-1	
H1-2	+3.3V		H1-20A10-2	
H1-3	GND		H1-30A10-3	Two wires
H1-3B	GND		H1-30A10-3B	
H1-4	+5V		H1-40A10-4	Two wires
H1-4B	+5V		H1-40A10-4B	
H1-5	GND		H1-50A10-5	
H1-6	+5V		H1-60A10-6	
H1-7	GND		H1-70A10-7	
H1-8	PS-ON		H1-80A10-8	
H1-9	+5V SB		H1-90A10-9	
H1-10	+12V		H1-100A10-10	Two wires
H1-11	+12V		H1-110A10-11	
H1-12	+3.3V		H1-120A10-12	
H1-13	+3.3V		H1-130A10-13	Two wires
H1-14	12V		H1-140A10-14	
H1-15	GND		H1-150A10-15	
H1-16	PS-ON		H1-160A10-16	
H1-17	GND		H1-170A10-17	
H1-18	GND		H1-180A10-18	
H1-19	GND		H1-190A10-19	
H1-20	5V		H1-200A10-20	
H1-21	+5V		H1-210A10-21	
H1-22	+5V		H1-220A10-22	
H1-23	+5V		H1-230A10-23	
H1-24	GND		H1-240A10-24	

Technical Requirements:

1. The terminals are made of phosphor bronze.
2. The wire material is UL2468 18AWG with a temperature resistance of 80°C and a voltage rating of 300V.
3. The wire material number is PJA-072. It can be ordered as needed.

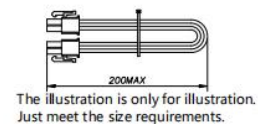

The illustration is only for illustration. Just meet the size requirements.

Quantity: 1pcs

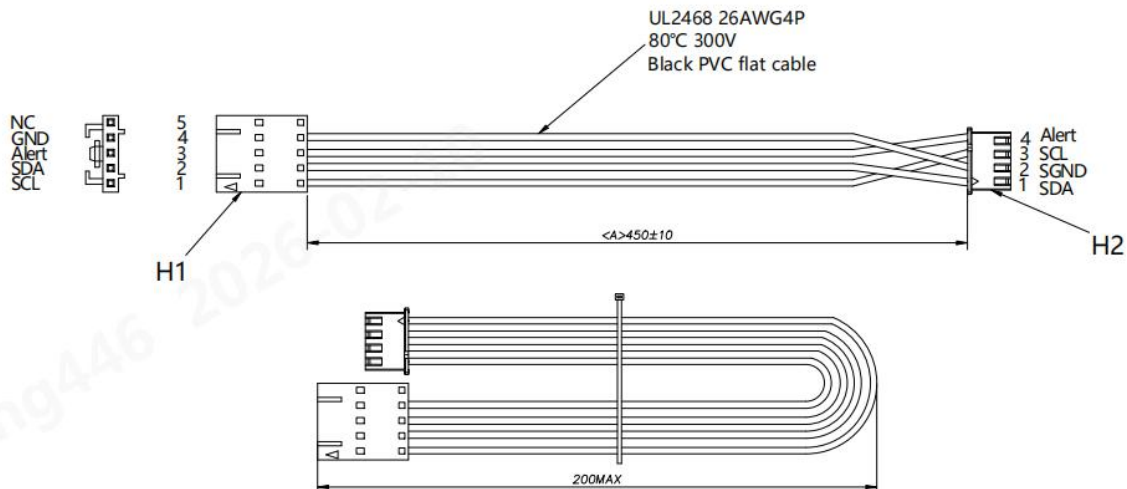

Technical Requirements:

1. The terminals are made of phosphor bronze.
2. The wire material is UL2468 18AWG with a temperature resistance of 80°C and a voltage rating of 300V.
3. The wire material number is PJA-072. It can be ordered as needed.

The illustration is only for illustration.
Just meet the size requirements.

Quantity: 1pcs

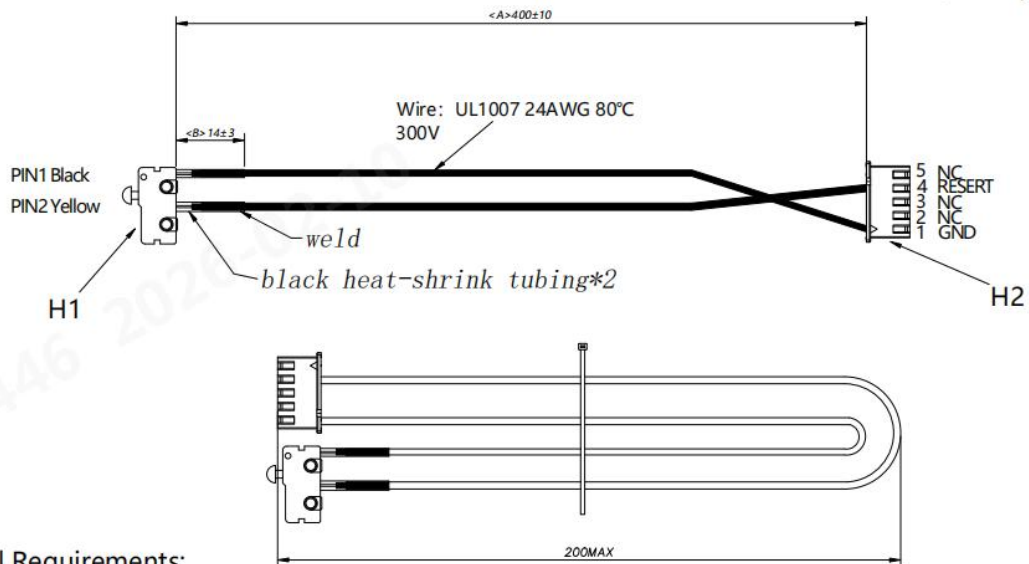

Technical Requirements:

1. The terminals are made of phosphor bronze.
2. Switch: BEJ KW02 *1 (beierjia or equivalent product).
3. The wire material is UL1007 24AWG with a temperature resistance of 80°C and a voltage rating of 300V.
4. The wire material number is PJA-072. It can be ordered as needed.

Dimensions and Recommended Layout

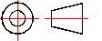
THIRD ANGLE PROJECTION 

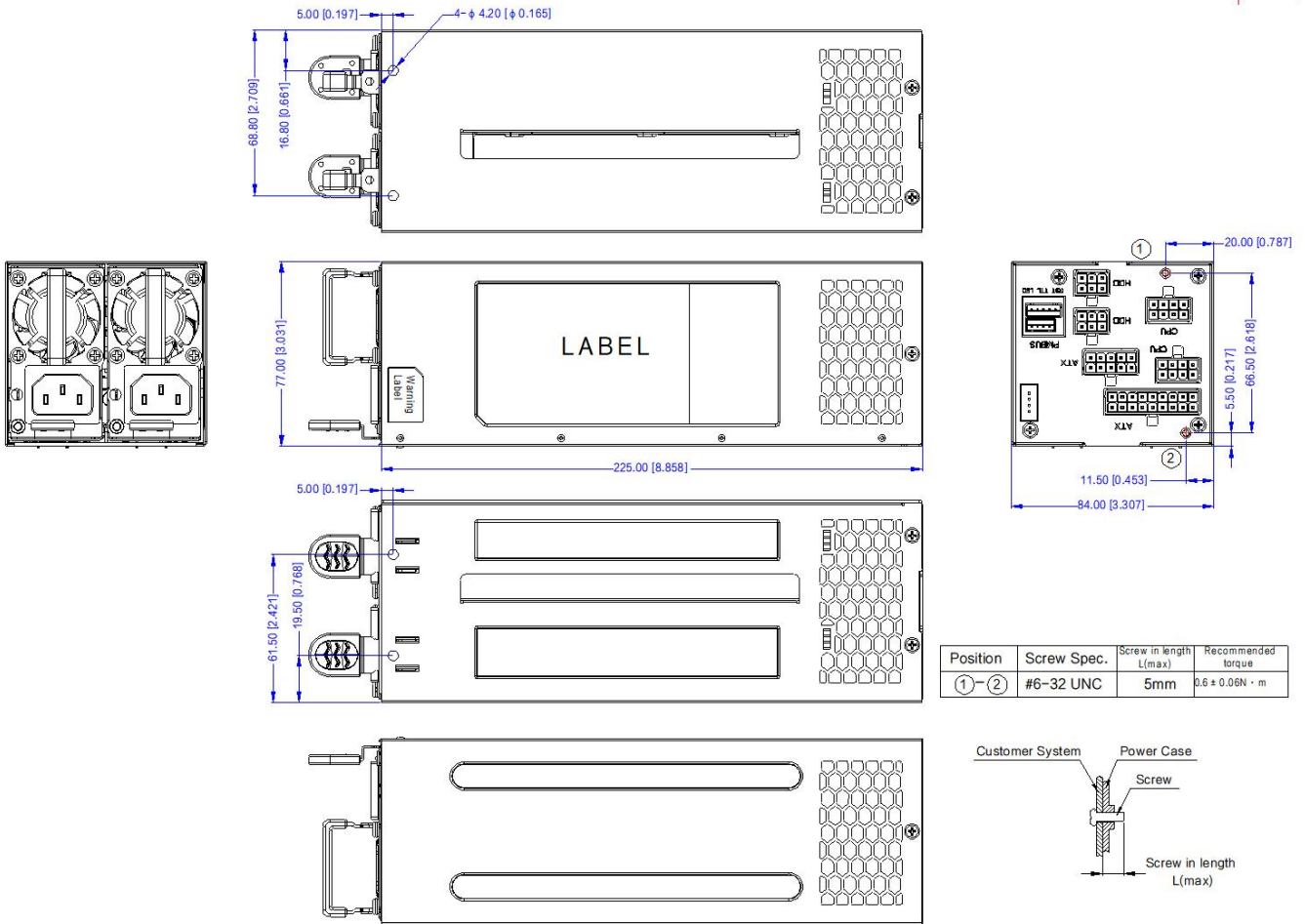

Note:
Unit: mm[inch]
General tolerances: ± 0.50[± 0.02]

Mounting Bracket

THIRD ANGLE PROJECTION 

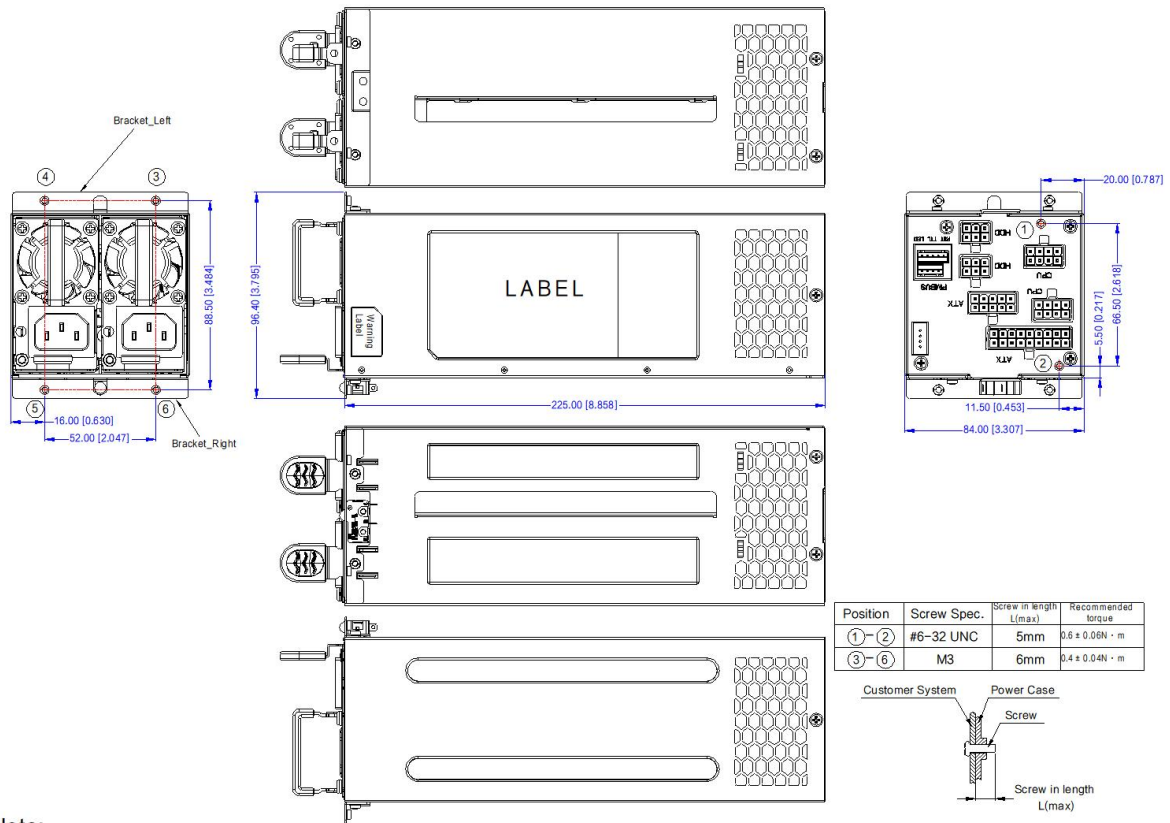

Note:
Unit: mm[inch]
General tolerances: ± 0.50 [± 0.02]

Diagram of bracket installation

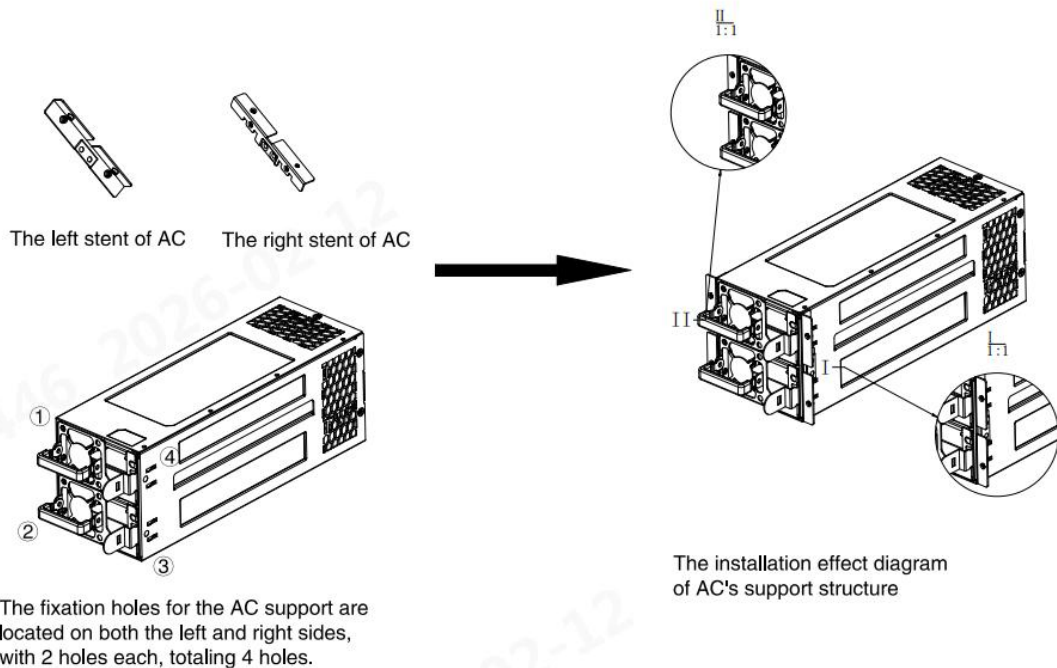

Note:

1. According to application requirements, the fixed bracket AC end bracket PJA-073 can be optionally selected.
2. Material of AC end bracket accessories: SGCC (DX51D + Z80), $T = 1.0 \pm 0.08\text{mm}$.
3. Installation holes: M3 countersunk screw thread, recommended torque 4.5 kgf.cm.

Note:

1. For additional information on Product Packaging please refer to www.mornsun-power.com. -PDB Packaging bag number: 58220904, -W Packaging bag number: 58220775
2. Unless otherwise specified, parameters in this datasheet were measured under the conditions of $T_a=25^\circ\text{C}$, humidity <75%RH with nominal input voltage and rated output load;
3. The room temperature derating of $1^\circ\text{C}/300\text{m}$ is needed for operating altitude greater than 2000m;
4. All index testing methods in this datasheet are based on our company corporate standards;
5. In order to improve the efficiency at high input voltage, there will be audible noise generated, but it does not affect product performance and reliability;
6. Products are related to laws and regulations: see "Features";
7. The out case needs to be connected to PE (⊕) of system when the terminal equipment in operating;
8. Our products shall be classified according to ISO14001 and related environmental laws and regulations, and shall be handled by qualified units;
9. The power supply is considered a component which will be installed into a terminal equipment. All EMC tests should be confirmed with the final equipment. Please consult our FAE for EMC test operation instructions.

Mornsun Guangzhou Science & Technology Co., Ltd.

Address: No. 8 Nanyun 4th Road, Huangpu District, Guangzhou, China

Tel: 86-20-38601850

Fax: 86-20-38601272

E-mail: info@mornsun.cn

www.mornsun-power.com