



## FEATURES

- Input voltage range: 320 - 528VAC or 450 - 750VDC
- Operating ambient temperature range: -40°C to +85°C
- High efficiency, high reliability
- 1U height shape
- LED indicate the power on
- Operating altitude up to 5000m
- Output short circuit, over-current, over-voltage protection, over-temperature protection
- Safety according to UL/IEC/EN62368, GB4943
- 3 years warranty

LM350-26B24 is the ultra-small Mornsun second-generation new industrial standard enclosed power supply, which has innovated the industrial power supply standard from the aspect of dimension, performance, technology and structure. It features general AC input and at the same time accepts DC input voltage, cost-effective, low no load power consumption, high efficiency, high reliability and double or reinforced insulation. The converter offer excellent EMC performance and meet UL/IEC/EN62368, GB4943 standards and it is widely used in areas of industrial, LED, street light control, security, telecommunications, smart home, etc.

## Selection Guide

Certification	Part No.	Output Power (W)	Nominal Output Voltage and Current (Vo/Io)	Output Voltage Adjustable Range (V)	Efficiency at 230VAC (%) Typ.	Capacitive Load (uF) Max.
--	LM350-26B24	350.4	24V/14.6A	22.8-27.6	86	1500

Note:  
 1. Under any conditions, the total power of the product should not exceed the rated power. When the output voltage is increased, the total output power cannot exceed the rated output power, when the output voltage is decreased, the output current cannot exceed the rated output current.  
 2. The product picture is for reference only. For details, please refer to the actual product.

## Input Specifications

Item	Operating Conditions		Min.	Typ.	Max.	Unit
Input Voltage Range	Rated input (Certified voltage)		380	--	480	VAC
	AC input		320	--	528	
	DC input		450	--	750	VDC
Input Frequency			47	--	63	Hz
Input Current	380VAC		--	--	2.5	A
	480VAC		--	--	2.1	
Inrush Current	380VAC	Cold-start	--	60	100	
Start-up Delay Time			--	--	3	s
Input fuse	Built in fuse		--	4	--	A
Hot Plug			Unavailable			

## Output Specifications

Item	Operating Conditions		Min.	Typ.	Max.	Unit
Output Voltage Accuracy	Full load range		--	±1	--	%
Line Regulation	Rated load		--	±0.5	--	
Load Regulation	0% - 100% load		--	±0.5	--	
Minimum Load			0	--	--	
Ripple & Noise*	20MHz bandwidth (peak-peak value)		--	--	240	mV
Stand-by Power Consumption			--	--	5	W
Temperature Coefficient	480VAC, 0°C to 50°C		--	0.03	--	%/°C
Hold-up Time	380VAC		--	12	--	ms
	480VAC		--	16	--	
Short Circuit Protection	Recovery time <5s after the short circuit disappear.		Hiccup, continuous, self-recover			

Over-current Protection		130% - 220% I <sub>o</sub> , self-recover
Over-voltage Protection	24V	≤33.6V (full load for hiccup or light load for clamp, self-recover)
Over-temperature Protection	380VAC, rated load, 85°C	Output voltage turn off, self-recovery
Note: *The "Tip and barrel method" is used for ripple and noise test, output parallel 47μF electrolytic capacitor and 0.1μF ceramic capacitor, please refer to enclosed Switching Power Supply Application Notes for specific information.		

## General Specifications

Item	Operating Conditions		Min.	Typ.	Max.	Unit
Isolation	Input - output	Electric strength test for 1min., leakage current <5mA	4000	--	--	VAC
	Input - ⊕		2000	--	--	
	Output - ⊕	Electric strength test for 1min., leakage current <10mA	500	--	--	
Insulation Resistance	Input - output	Environment temperature: 25±5°C Relative humidity: <95%RH, non-condensing Testing voltage: 500VDC	100	--	--	MΩ
	Input - ⊕		100	--	--	
	Output - ⊕		100	--	--	
Operating Temperature		-40	--	+85	°C	
Storage Temperature		-40	--	+85	°C	
Storage Humidity	Non-condensing	--	--	95	%RH	
Operating Humidity		--	--	90		
Switching Frequency		--	65	--	KHz	
Power Derating	Operating temperature derating	-40°C to -30°C	2	--	--	% / °C
		+50°C to +85°C	2	--	--	
	Input voltage derating	320VAC - 340VAC	1	--	--	% / VAC
Touch Leakage Current	1.1*480VAC	2mA Max.				
Safety Standards		Design refer to GB4943.1, UL/IEC/EN62368-1				
Safety Class		CLASS I				
MTBF	MIL-HDBK-217F@25°C	≥300,000h				
Warranty	Ambient temperature: <70°C	3 years				

## Environmental Characteristics

Item	Operating Conditions	Standard
Low Temperature Working	-40°C	GB2423.1, IEC60068-2-1
High Temperature Working	+85°C	GB2423.2, IEC60068-2-2
Low Temperature Storage	-40°C	GB2423.1, IEC60068-2-1
High Temperature Storage	+85°C	GB2423.2, IEC60068-2-2
High Temperature Aging	+50°C	GB2423.2, IEC60068-2-2
Normal Temperature Aging	+25°C	GB2423.1, IEC60068-2-1
Sinusoidal Vibration	10 - 500Hz, 5G, three directions of X, Y, Z axis	GB2423.10, IEC60068-2-6
Temperature Shock	-40°C to +85°C	GB2423.22, IEC60068-2-14
Temperature Cycle	-30°C to +50°C	GB2423.22, IEC60068-2-14
Hot and Humid	+85°C, 85%RH	GB2423.50, IEC60068-2-67

## General Specifications

Case Material	Metal (AL5052, SGCC)
Dimensions	215.00mm x 115.00mm x 30.00mm
Weight	670g (Typ.)
Cooling Method	Forced air cooling
Note: Cooling method and power derating refer to typical characteristic curves	

Electromagnetic Compatibility (EMC)

Emissions	CE	CISPR32/EN55032	CLASS A	
	RE	CISPR32/EN55032	CLASS A	
Immunity*	ESD	IEC/EN61000-4-2	Contact ±6KV/Air ±8KV	perf. Criteria A
	RS	IEC/EN61000-4-3	10V/m	perf. Criteria A
	EFT	IEC/EN61000-4-4	±4KV	perf. Criteria A
	Surge	IEC/EN61000-4-5	line to line ±2KV/line to PE ±4KV	perf. Criteria A
	PFMF	IEC/EN61000-4-6	10 Vr.m.s	perf. Criteria A
	CS	IEC/EN61000-4-8	30A/m	perf. Criteria A
	Voltage dips	IEC/EN61000-4-11	70% Un, 25/30 cycle(50/60Hz) 40% Un, 10/12 cycle(50/60Hz) 0% Un, 1 cycle (Un is the maximum input nominal voltage)	perf. Criteria B
	Voltage interruption	IEC/EN61000-4-11	0% Un, 250/300 cycle(50/60Hz) (Un is the maximum input nominal voltage)	perf. Criteria C

Remark:

- One magnetic bead should be coupled with the output load line during CE/RE testing.
- The power supply does not meet the requirements of harmonic current stipulated in EN61000-3-2; This power supply is not suitable for the following situations:
  - The terminal equipment is used in the European Union;
  - The terminal equipment is connected to public mains supply with 220VAC or greater rated nominal voltage that mandatory to meet the requirements of EN61000-3-2;
  - The power supply is installed in terminal equipment with average or continuous input power greater than 75W;
  - The power supply belong to a part of lighting system;
 In addition, the power supply can be used in the following terminals which do not need to meet EN61000-3-2;
  - Professional equipment with total fixed input power greater than 1000W;
  - symmetrical controlled heating element with rated power less than or equal to 200W.
- If no harmonic current is required or customers can solve harmonic current problems by themselves, this product can be used.

Product Characteristic Curve

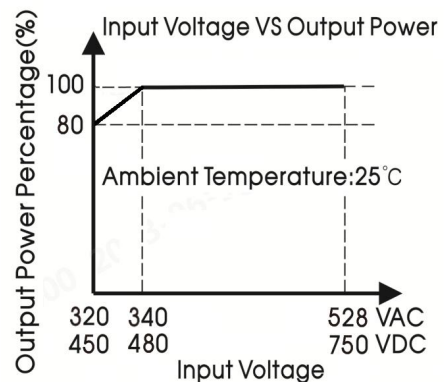
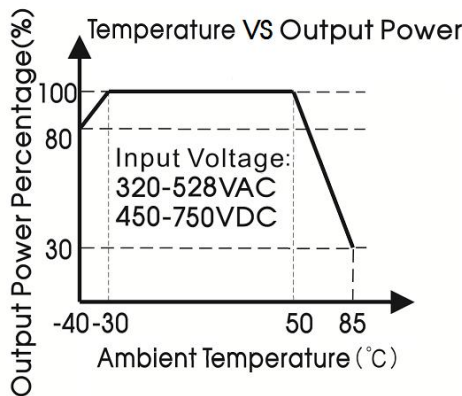

Note: 1. With an AC input voltage between 320-340VAC and a DC input between 450-480VDC the output power must be derated as per the temperature derating curves;  
2. This product is suitable for applications using forced air cooling; for applications in closed environment please consult Mornsun FAE.

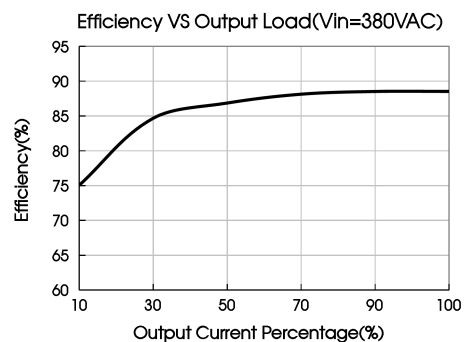
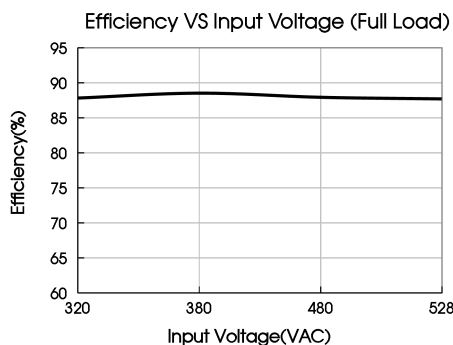

Note:

The product is equipped with a built-in cooling fan. Keep the air intake clear of debris. If the environment cannot meet this requirement, a fanless model is recommended.

Dimensions and Recommended Layout

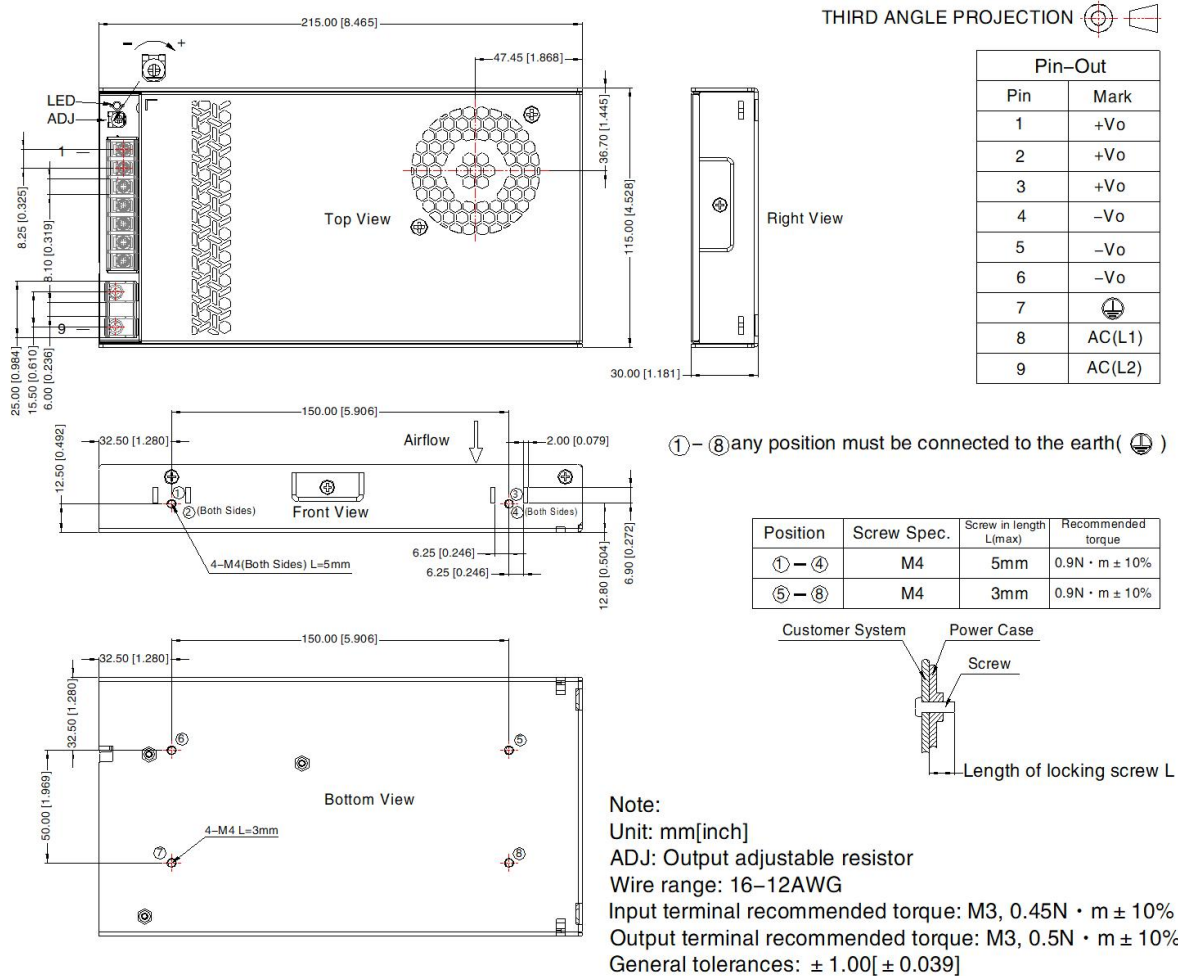

Note:

- For additional information on Product Packaging please refer to [www.mornsun-power.com](http://www.mornsun-power.com). Packaging bag number: 58220729;
- Unless otherwise specified, parameters in this datasheet were measured under the conditions of Ta=25°C, humidity <75%RH with nominal input voltage and rated output load;
- The room temperature derating of 5°C/1000m is needed for operating altitude greater than 2000m;
- All index testing methods in this datasheet are based on our company corporate standards;
- In order to improve the efficiency at high input voltage, there will be audible noise generated, but it does not affect product performance and reliability;
- We can provide product customization service, please contact our technicians directly for specific information;
- Products are related to laws and regulations: see "Features" and "EMC";
- The out case needs to be connected to PE (⊕) of system when the terminal equipment in operating;
- The output voltage can be adjusted by the ADJ, clockwise to increase;
- Our products shall be classified according to ISO14001 and related environmental laws and regulations, and shall be handled by qualified units;
- The power supply is considered a component which will be installed into a terminal equipment. All EMC tests should be confirmed with the final equipment. Please consult our FAE for EMC test operation instructions.

Mornsun Guangzhou Science & Technology Co., Ltd.

Address: No. 8 Nanyun 4th Road, Huangpu District, Guangzhou, China

Tel: 86-20-38601850

Fax: 86-20-38601272

E-mail: info@mornsun.cn

www.mornsun-power.com