



FEATURES

- Wide 3x 320-575VAC and 450-820VDC Input voltage range
- Operating ambient temperature range: -40°C to +70°C
- Active PFC, PF up to 0.95
- Standard DIN-Rail mounting
- High efficiency, high reliability
- DC OK, Supporting parallel (3+1 current sharing)
- Double-sided conformal coating
- Output short circuit, over-current, over-voltage protection, over-temperature protection
- Operating altitude up to 5000m
- Safety according to UL/EN/IEC62368, EN/IEC61000, UL/EN61010, CISPR32/EN55032, UL508

LITF960-26BxxS is one of Mornsun's three-phase Din-Rail switching power supply. It features cost-effective, high efficiency, high reliability and security isolation. It offer excellent EMC performance and meet UL/EN/IEC62368, EN/IEC61000, UL/EN61010, CISPR32/EN55032, UL508 standards and they are widely used in areas of industrial control equipment, factory automation and mechanical and electrical equipment and other industrial control fields.

Selection Guide

Part No.	Cooling Method	Output Power (W)	Nominal Output Voltage and Current (Vo/Io)	Output Voltage Adjustable Range (V)	Efficiency at 3x400VAC (%) Typ.	Max. Capacitive Load (uF)
LITF960-26B24S	Air cooling	960	24V/40A	24-28	95	40000
LITF960-26B48S			48V/20A	48-56	96	20000

Note: The product picture is for reference only. For details, please refer to the actual product.

Input Specifications

Item	Operating Conditions		Min.	Typ.	Max.	Unit
Input Voltage Range	Rated input (Certified voltage)		380	--	480	VAC
	AC input		320	--	575	VAC
	DC input		450	--	820	VDC
Input Voltage Frequency	Rated input (Certified voltage)		50	--	60	Hz
	AC input		47	--	63	
Input Current	Rated input (Certified voltage)		--	--	2	A
	400VAC		--	--	2	
	500VAC		--	--	1.5	
Inrush Current	400VAC	Cold start	--	60	--	
Power Factor	400VAC	Normal temperature, rated load	0.94	0.95	--	--
	500VAC		0.93	0.94	--	
Input Under-voltage Protection	Under-voltage protection start (Input voltage drops from high to low)		275	--	--	VAC
	Under-voltage protection release (Input voltage rises from low to high)		--	--	305	
Input Fuse	Built-in fuse		6.3A/600V			
Hot Plug			Unavailable			

Output Specifications

Item	Operating Conditions		Min.	Typ.	Max.	Unit
Output Voltage Accuracy	Full load range		--	±1	--	%
Line Regulation	Rated load		--	±0.5	--	
Load Regulation	0% - 100% load		--	±1	--	
Minimum Load			0	--	--	
Ripple & Noise*	20MHz bandwidth	24V	--	--	180	mV
	(peak-to-peak value)	48V	--	--	250	
Temperature Coefficient			--	±0.03	--	%/°C
Hold-up Time	400VAC		--	20	--	ms
	500VAC		--	20	--	
Short Circuit Protection	Constant current mode, continuous, self-recover					
Over-current Protection	105% - 130% I _o , Constant current mode, automatic recover after fault condition is removed					
Over-voltage Protection	24V		≤35VDC (Hiccup, self-recover)			
	48V		≤63VDC (Hiccup, self-recover)			
Over-temperature Protection	Output voltage turn off, self-recover after fault elimination					

Note: *The "Tip and barrel method" is used for ripple and noise test, output parallel 47μF electrolytic capacitor and 0.1μF ceramic capacitor, please refer to Enclosed Switching Power Supply Application Notes for specific information.

General Specifications

Item	Operating Conditions		Min.	Typ.	Max.	Unit
Isolation	Input - ⊕	Electric strength test for 1min, leakage current < 10mA	2000	--	--	VAC
	Input - output	Electric strength test for 1min, leakage current < 5mA	4000	--	--	
	Output - ⊕	Electric strength test for 1min, leakage current < 10mA	500	--	--	
	Output - DC OK	Electric strength test for 1min, leakage current < 1mA	500	--	--	
Insulation Resistance	Input - ⊕	Environment temperature: 25±5°C	100	--	--	MΩ
	Input - output	Relative humidity: < 95%, non-condensing	100	--	--	
	Output - ⊕	Test voltage: 500VDC	100	--	--	
Touch Leakage Current	3x 480VAC		--	--	2	mA
Operating Temperature			-40	--	70	°C
Storage Temperature			-40	--	85	
Operating Humidity	Non-condensing		20	--	90	%RH
Storage Humidity			10	--	95	
Switching Frequency			55	--	75	kHz
Power Derating	Operating temperature derating	-40°C to -30°C	5	--	--	% / °C
		-30°C to +50°C	0	--	--	
		+50°C to +70°C	2.5	--	--	
	Input voltage derating	320VAC - 340VAC (Three phase operation)	1	--	--	%/VAC
Safety Standard*	Design refer to IEC/EN/UL62368-1, UL/EN61010-1, UL508, UL/EN61010-2-201					
Safety Class	CLASS I, ANSI/ISA71.04-2013					
MTBF	MIL-HDBK-217F@25°C		≥250,000 h			
Warranty	3years					
Pollution Degree	2					

Note: * Indoor use meets UL 61010 certification standards.

Mechanical Specifications

Case Material	Metal (AL5052, SPCC)
Dimensions	110.00mm x 124.00mm x 127.00mm
Weight	1650g (Typ.)
Cooling Method	Free air convection

Electromagnetic Compatibility (EMC)

Emissions	CE	CISPR32/EN55032	CLASS B	
	RE	CISPR32/EN55032	CLASS B	
	Harmonic current	IEC/EN61000-3-2	CLASS A	
	Voltage flicker	EN61000-3-3		
Immunity	ESD	IEC/EN61000-4-2	Contact ±8KV/Air ±15KV	perf. Criteria A
	RS	IEC/EN61000-4-3	10V/m	perf. Criteria A
	EFT (Input)	IEC/EN61000-4-4	±4KV	perf. Criteria A
	EFT (Output)	IEC/EN61000-4-4	±2KV	perf. Criteria A
	EFT (DC OK)	IEC/EN61000-4-4	±1KV	perf. Criteria A
	Surge (Input)	IEC/EN61000-4-5	line to line ±2KV/line to PE ±4KV	perf. Criteria A
	Surge (Output)	IEC/EN61000-4-5	Vo+ to Vo- ±500V/Vo+/Vo- to PE ±1KV	perf. Criteria A
	Surge (DC OK)	IEC/EN61000-4-5	DC OK to PE ±1KV	perf. Criteria A
	CS	IEC/EN61000-4-6	20 Vr.m.s	perf. Criteria A
	PFMF	IEC/EN61000-4-8	30A/m	perf. Criteria A
	Voltage variations*	IEC61000-6-2/IEC61000-4-11	70% Un, 25/30 cycle(50/60Hz) 40% Un, 0/12 cycle(50/60Hz) 0% Un, 1 cycle	perf. Criteria B
Voltage interruptions*	IEC61000-6-2/IEC61000-4-11	0% Un, 250/300 cycle(50/60Hz)	perf. Criteria C	

Note: *Un is the maximum input nominal voltage.

Functional Specifications

Item	Operating Conditions	Min.	Typ.	Max.	Unit
Current Sharing Accuracy	When multiple units are connected in parallel, the sub-modules shunt more than 50% of the rated load	-5	--	+5	%
DC OK Signal	Resistive load	30VDC/1A Max.			
LED Signal	Main output status indication	Normal output >90%Vo	Green On		

Environmental Characteristics

Item	Operating Conditions	Standard
High and Low Temperature Working	+70℃, -40℃	GB2423.1, IEC60068-2-1
Sinusoidal Vibration	10 - 500Hz, 2G, three directions of X, Y, Z axis	GB2423.10, IEC60068-2-6
Low Temperature Storage	-40℃	GB2423.1, IEC60068-2-1
High Temperature Storage	+85℃	GB2423.2, IEC60068-2-2
High Temperature Aging	+50℃	GB2423.2, IEC60068-2-2
Normal Temperature Aging	+25℃	GB2423.1, IEC60068-2-1
Temperature Shock	-40℃ to +85℃	GB2423.22, IEC60068-2-14
Temperature Cycle	-30℃ to +50℃	GB2423.22, IEC60068-2-14
Hot and Humid	+70℃, 85%RH	GB2423.50, IEC60068-2-67

Installation Diagram

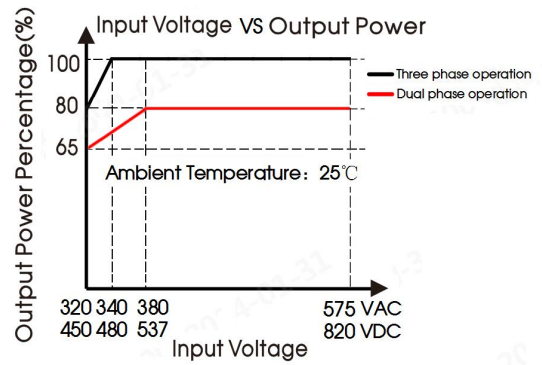
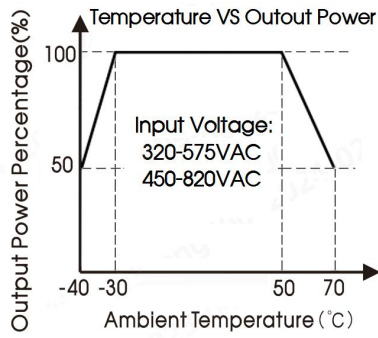

- Note:
1. With an AC input voltage between 320-340VAC/320-380VAC and a DC input between 450-480VDC/450-537VDC, the output power must be derated as per the temperature derating curves.
 2. This product is suitable for applications using air cooling; for applications in closed environment please consult Mornsun FAE.

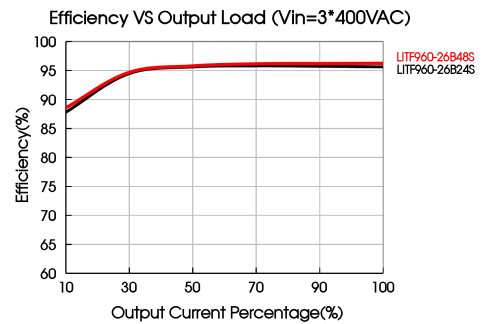
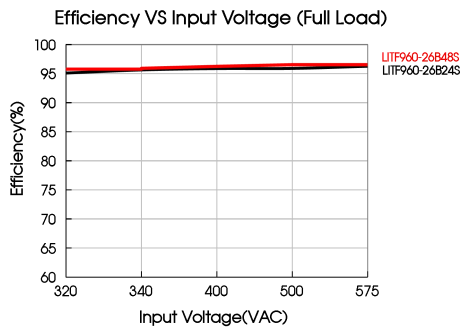

Installation Diagram

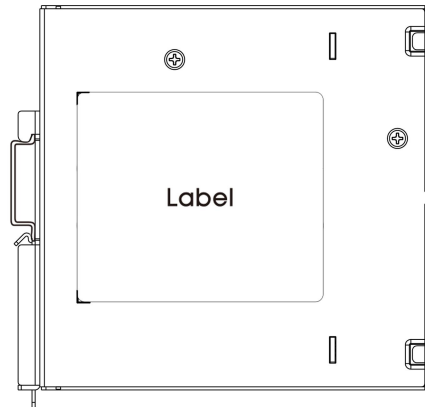
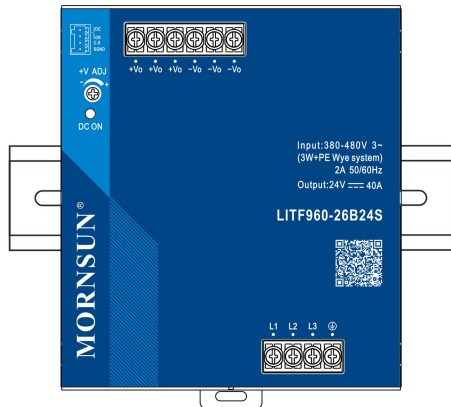

Materials required in the installation		
1	Product	1PCS
2	Phillips screwdriver Slotted screwdriver	1PCS
3	TS35/7.5 or TS35/15	1PCS
4	24-10AWG Wire	/ PCS
5	The content is for reference only. Regarding the actual wire diameter and tightening torque, refer to the dimensional drawing.	



Product



Phillips screwdriver
Slotted screwdriver
Diameter : 3mm



TS35/7.5 or TS35/15



Thread: 8mm

Installation steps ①-②

① Clamp the buckle of the product into the TS35 DIN rail.

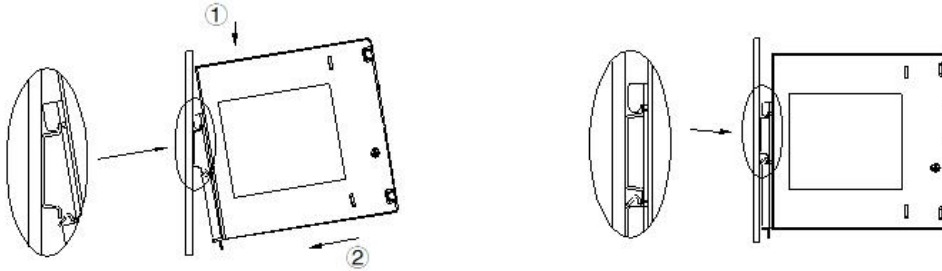

② Push the product vertically towards the TS35 DIN rail until hearing the sound of the buckle snapping into it.

Disassembly Steps ③-④

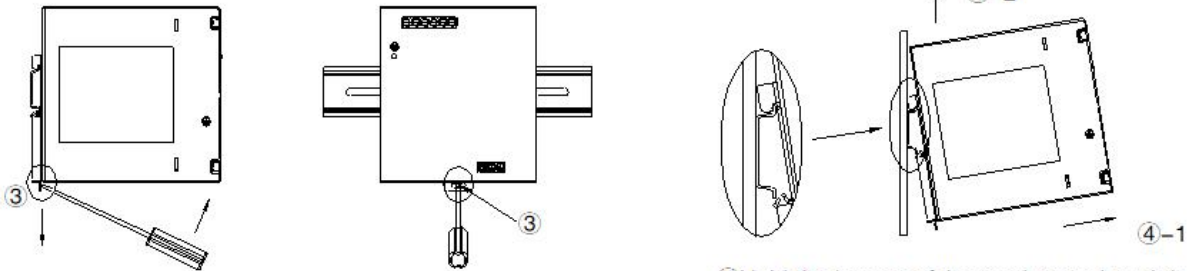

③ After inserting the slotted screwdriver into the square groove at the bottom of the buckle, push the slider of the buckle downward in the direction shown in the figure.

④ Hold the bottom of the product and push it outwards while pushing down the slider, then lift the product up to take the product out of the DIN rail.

Wiring / Unwiring Steps ⑤-⑥

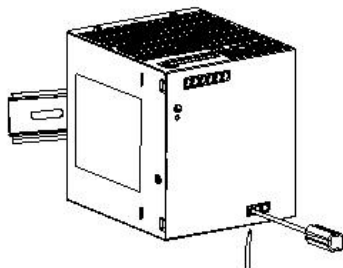

⑤ Turn the Phillips screwdriver to the left to loosen the terminal screws, insert the head of the wire into the bottom of the terminal, and then turn the screwdriver to the right to tighten the terminal screws

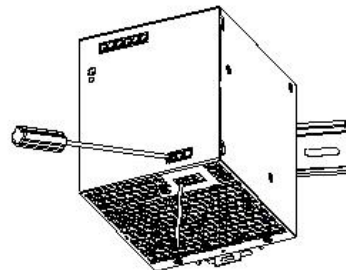

⑥ Turn the Phillips screwdriver to the left to loosen the terminal screw and pull the wire out of the bottom of the terminal

Note: Keep the following installation clearances: 20mm on top, 20mm on the bottom, 5mm on the left and right sides are recommended when the device is loaded permanently with more than 50% of the rated power. Increase this clearance to 15mm in case the adjacent device is a heat source (e.g. another power supply).

Dimensions and Recommended Layout

THIRD ANGLE PROJECTION 

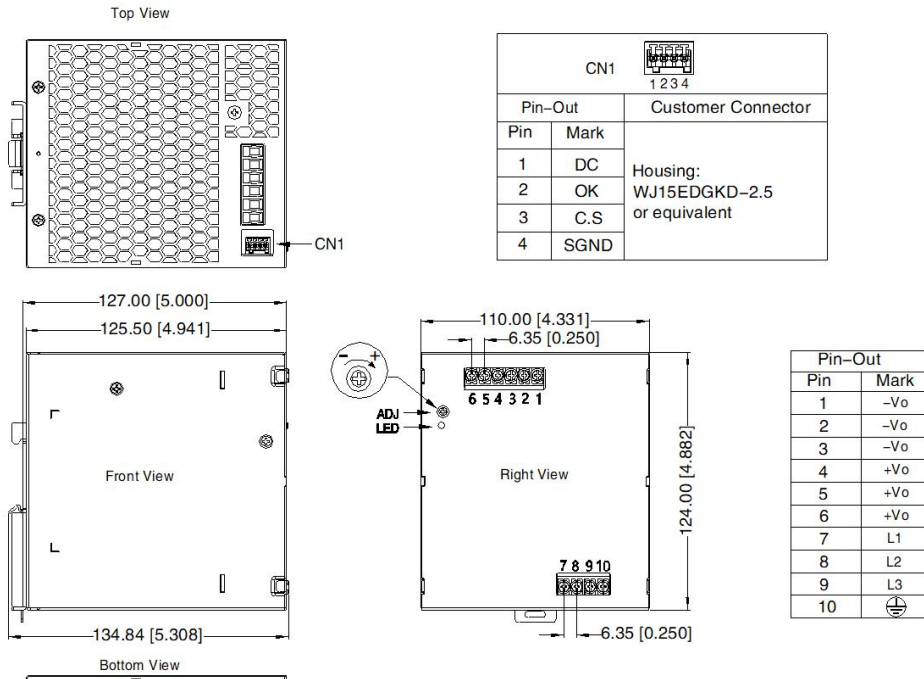

Note:
Unit: mm[inch]
ADJ: Output adjustable resistor
Wire range: Input: 22-10AWG
Output: 24V: 10AWG
48V: 14-10AWG
Tightening torque: Max 0.5 N · m
Mounting rail: TS35, rail needs to connect safety ground
General tolerances: ± 1.00[± 0.039]

Parallel function description

1. The wiring method of parallel operation is shown in the figure below(PCS parallel connection).
2. The output voltage difference between the parallel units should be as small as possible.
3. Supports 3+1 parallel to increase power and current sharing, please consult our FAE for details.
4. The power supply should be connected to the load with short and thick parallel wires.

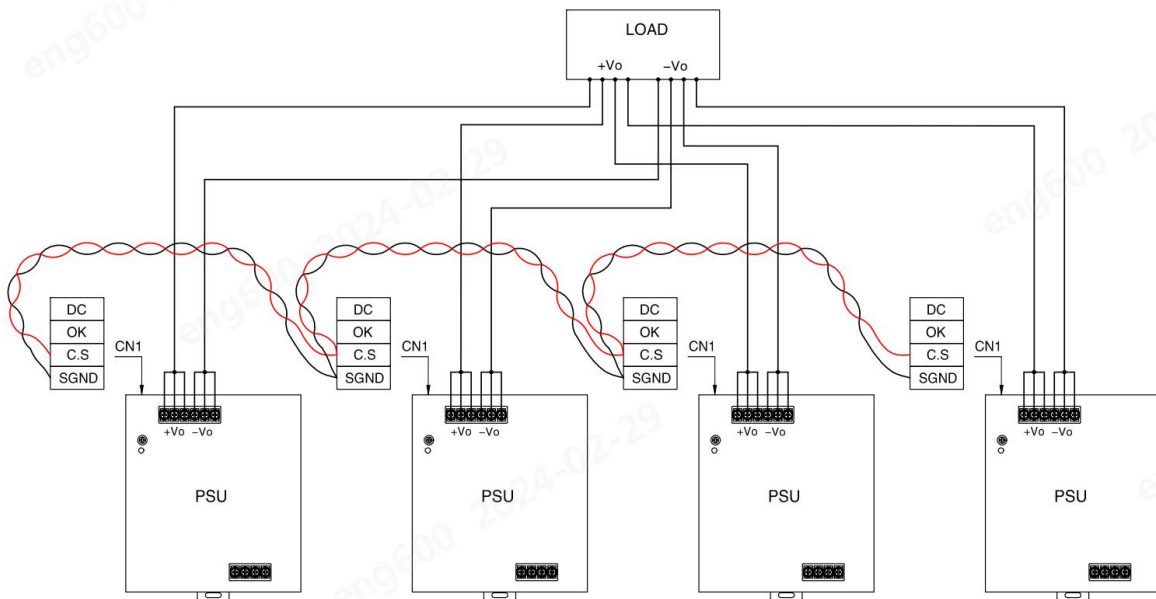



WARNING Risk of electrical shock, fire, personal injury or death:

AVERTISSEMENT AVERTISSEMENT Risque de choc électrique, d'incendie, de blessures corporelles ou de décès :

1. Do not use the power supply without proper grounding (Protective Earth). Use the terminal on the input block for earth connection and not one of the screws on the housing;
N'utilisez pas l'alimentation électrique sans mise à la terre appropriée (Terre protectrice). Utilisez le terminal sur le bloc d'entrée pour la connexion terrestre et non pas une des vis sur le boîtier;
2. Turn power off before working on the device, protect against inadvertent re-powering;
Éteignez l'alimentation avant de travailler sur l'appareil, protégez-vous contre la réénergisation accidentelle;
3. Make sure that the wiring is correct by following all local and national codes;
Assurez-vous que le câblage est correct en suivant tous les codes locaux et nationaux;
4. Do not modify or repair the unit;
Ne modifiez pas ou ne réparez pas l'appareil;
5. Do not open the unit as high voltages are present inside;
Ne modifiez pas ou ne réparez pas l'appareil;
6. Use caution to prevent any foreign objects from entering the housing;
Faire preuve de prudence pour empêcher les objets étrangers d'entrer dans le logement;
7. Do not use in wet locations or in areas where moisture or condensation can be expected;
Faire preuve de prudence pour empêcher les objets étrangers d'entrer dans le logement;
8. Do not touch during power-on, and immediately after power-off, hot surfaces may cause burns; 
Ne touchez pas pendant l'alimentation et, immédiatement après l'alimentation, les surfaces chaudes peuvent causer des brûlures.
9. Use copper conductors only;
N'utiliser que des conducteurs en cuivre;
10. OPEN EQUIPMENT: Adequate protection against contact with live parts and ingress of dust and water must be ensured through installation in a suitable enclosure (e.g. control cabinet, control box console or similar).

Note:

1. For additional information on Product Packaging please refer to www.mornsun-power.com, Packaging bag number: 58220640;
2. Unless otherwise specified, parameters in this datasheet were measured under the conditions of $T_a=25^{\circ}\text{C}$, humidity<75%RH with nominal input voltage and rated output load;
3. The room temperature derating of $3.5^{\circ}\text{C}/1000\text{m}$ is needed for operating altitude greater than 2000m;
4. All index testing methods in this datasheet are based on our company corporate standards;
5. In order to improve the efficiency at high input voltage, there will be audible noise generated, but it does not affect product performance and reliability;
6. We can provide product customization service, please contact our technicians directly for specific information;
7. Products are related to laws and regulations: see "Features" and "EMC";
8. The out case needs to be connected to the earth (\oplus) of system when the terminal equipment in operating;
9. The output voltage can be adjusted by the ADJ, clockwise to increase;
10. Our products shall be classified according to ISO14001 and related environmental laws and regulations, and shall be handled by qualified units;
11. The power supply is considered a component which will be installed into a terminal equipment. All EMC tests should be confirmed with the final equipment. Please consult our FAE for EMC test operation instructions.

Mornsun Guangzhou Science & Technology Co., Ltd.

Address: No. 5, Kehui St. 1, Kehui Development Center, Science Ave., Guangzhou Science City, Huangpu District, Guangzhou, P. R. China

Tel: 86-20-38601850

Fax: 86-20-38601272

E-mail: info@mornsun.cn

www.mornsun-power.com