



CE Report

EN 62368-1

UK Report

BS EN 62368-1

FEATURES

- Universal 3x320-600VAC or 450-800VDC Input voltage
- Active PFC,PF up to 0.94(Typ)
- Operating ambient temperature range: -40°C to +85°C, 60°C @ 100% load without derating
- Standard DIN-Rail mounting
- High efficiency, high reliability
- LED indicator for output status
- 200% peak power lasts for 3s
- Output short circuit, over-current, over-voltage, over-temperature protection
- Support 3+1 parallel redundancy, current sharing against backflow voltage
- Operating altitude up to 5000m
- OVC III (Safety according to EN61010)(2000m)
- Design refer to ANSI/ISA 71.04-2013 G3, Three-proof treatment, with anti-salt fog
- Safety according to IEC/UL62368, UL61010, EN61558, GB4943.1、UL508、SEMIF47
- 5 years warranty

LITF480-26BXXR2 series is Mornsun AC-DC three-phase Din-Rail switching power supply. It features cost-effective, high efficiency and high reliability and security isolation. With 200% power reserve, enough to support starting DC motor or capacitive load and other heavy load. These converters offer excellent EMC performance and meet UL508, IEC/EN/UL62368, UL61010, EN61558, SEMIF47 standards and they are widely used in areas of industrial control equipment, factory automation and mechanical and electrical equipment and other industrial control fields.

Selection Guide

Certification	Part No.	Output Power (W)	Nominal Output Voltage and Current (Vo/Io)	Output Voltage Adjustable Range (V)	Efficiency at 400VAC (%) Typ.	Max. Capacitive Load (μF)
--	LITF480-26B12R2	360	12V/30A	12-14.4	94.5	20000
EN BS EN	LITF480-26B24R2	480	24V/20A	24-28	95	20000
	LITF480-26B36R2		36V/13.3A	36-42	95.5	20000
	LITF480-26B48R2		48V/10A	48-56	95.5	20000

Input Specifications

Item	Operating Conditions	Min.	Typ.	Max.	Unit
Input Voltage Range	Rated input (Certified voltage)	380	--	480	VAC
	AC input	320	--	600	
	DC input	450	--	800	VDC
Input Voltage Frequency	AC input rated frequency(Certified voltage)	50	--	60	Hz
	AC input	47	--	63	
Input Current	Input rated current(Certified voltage)	--	--	1.0	A
	400VAC	--	--	1.0	

Inrush Current	480VAC	Cold start	--	--	0.8	
	400VAC		--	3	10	
	480VAC		--	3	10	
Power Factor	400VAC	Normal temperature, rated load	0.86	0.94	--	--
	480VAC		0.88	0.93	--	
Leakage Current	480VAC	<2mA				
Hot Plug	Unavailable					

Output Specifications

Item	Operating Conditions		Min.	Typ.	Max.	Unit
Output Voltage Accuracy	Full load range		--	±1	--	%
Line Regulation	Rated load		--	±0.5	--	
Load Regulation	Rated Input Voltage		--	±0.5	--	
Ripple & Noise*	20MHz bandwidth (peak-to-peak value)	12V/24V	--	--	120	mV
		36V/48V	--	--	150	
Temperature Coefficient			--	±0.03	--	%/°C
Minimum Load			--	0	--	%
Standby Power	400VAC		--	10	15	W
	480VAC		--	10	15	
Start-up delay time	Full voltage, full load range (normal temperature, high temperature)		--	1	1.5	S
	Full voltage, full load range (low temperature)		--	--	3	
Hold-up Time	Normal temperature, 100% load	400VAC	18	22	--	ms
		480VAC	18	22	--	
Short Circuit Protection	Hiccup mode, continuous, self-recover					
Over-current Protection	110% - 200% Io hold for 3 sec then hiccups, automatic recover after fault condition is removed					
Over-voltage Protection	12V	15-18VDC (Output voltage hiccups, self-recover)				
	24V	30-35VDC (Output voltage hiccups, self-recover)				
	36V	44-53VDC (Output voltage hiccups, self-recover)				
	48V	58-63VDC (Output voltage hiccups, self-recover)				
Over-temperature Protection	400VAC, 100%load	Over-temperature Protection start	--	--	85	°C
		Over-temperature Protection release	60	--	--	

Note: 1.*The "Tip and barrel method" is used for ripple and noise test, output parallel 47uF electrolytic capacitor and 0.1uF ceramic capacitor, please refer to Enclosed Switching Power Supply Application Notes for specific information;

2.* The ambient temperature in the over-temperature protection performance is based on the ambient temperature 2cm below the guide rail as a reference.

General Specifications

Item	Operating Conditions		Min.	Typ.	Max.	Unit
Isolation Test	Input - ⊕	Electric strength test for 1min, leakage current <5mA	2500	--	--	VAC
	Input - Output		4870	--	--	
	Output - ⊕		500	--	--	
	Output - DC OK	Electric strength test for 1min, leakage current <1mA	500	--	--	
Insulation Resistance	Input - ⊕	Environment temperature: 25±5°C	100	--	--	MΩ
	Input - Output	Relative humidity: <95%, non-condensing	100	--	--	
	Output - ⊕	Test voltage: 500VDC	100	--	--	
Operating Temperature			-40	--	85	°C
Storage Temperature			-40	--	85	

Storage Humidity	Non-condensing		--	--	95	%RH	
Operating Humidity			20	--	90		
Switching Frequency*	PFC	Rated load	40	--	55	kHz	
	DC-DC		60	--	80		
Power Derating	Operating temperature derating		+60°C to +85°C	2.4	--	--	%/°C
	Input voltage derating (3P)		320VAC - 600VAC	--	--	--	%/VAC
	Input voltage derating (2P)		340VAC - 460VAC	0.166	--	--	
			460VAC - 600VAC	--	--	--	
Safety Standard			EN62368-1, BS EN62368-1(Report) Design refer to IEC/UL62368, UL61010, EN61558, GB4943.1, UL508, SEMIF47				
Safety Class			CLASS I, ANSI/ISA71.04-2013				
MTBF	MIL-HDBK-217F@25°C		≥300,000 h				
	MIL-HDBK-217F@40°C		≥186,000 h				
Pollution Degree	2						

Note: 1.*The power supply has two converters with two different switching frequencies.

Functional Specifications

Item	Operating Conditions		Min.	Typ.	Max.	Unit
Remote Control Switch(PS ON)	power turn-on		0	--	0.8	VDC
	power turn-off		4	--	20	
DC OK Signal	Full input voltage range, full load range	DC OK power on	0.95Vo - Vo			
		DC OK power off	<0.90Vo			
Oring			Support direct parallel use, achieve 3+1 parallel redundancy			
Current Sharing Accuracy*	When multiple units are connected in parallel, the sub-modules shunt more than 50% of the rated load		--	±5	--	%
LED Signal	Main output status indication	Normal work	Green On			
		Power Off (No AC input) or PS ON	Green Turn-off			

Note: 1.*When multiple units work with current sharing, the output voltage deviation of each power supply working alone shall not exceed 100mV.

Environmental Characteristics

Item	Operating Conditions	Standard
High and Low Temperature Working	+85°C, -40°C, 96H	GB2423.1, IEC60068-2-1
Sinusoidal Vibration	10 - 500Hz, 5g, three directions of X, Y, Z axis	GB2423.10, IEC60068-2-6
Salt Mist	+35°C, 5%NaCl, 48H	GB2423.17, IEC60068-2-11
Cyclic Damp Heat	+25°C, 95%RH - +60°C, 95%RH, 24H	GB2423.4, IEC60068-2-30
Low Temperature Storage	-40°C, 24H	GB2423.1, IEC60068-2-1
High Temperature Storage	+85°C, 24H	GB2423.2, IEC60068-2-2
High Temperature Aging	+60°C, 96H	GB2423.2, IEC60068-2-2
Normal Temperature Aging	+25°C, 24H	GB2423.1, IEC60068-2-1
Temperature Shock	-40°C to +85°C, 24H	GB2423.22, IEC60068-2-14
Temperature Cycle	-25°C to +60°C, 24H	GB2423.22, IEC60068-2-14
Hot and Humid	+85°C, 85%RH, 24H	GB2423.50, IEC60068-2-67
High Temperature Altitude	60°C, 54KPa	GB2423.26, IEC60068-2-41
Low Temperature Altitude	-40°C, 54KPa	GB2423.25, IEC60068-2-40
Sinusoidal Vibration Response	10 - 150Hz, 1g, three directions of X, Y, Z axis	GB/T 11287-2000, IEC60255-21-1
Sinusoidal Vibration Endurance Test		

Sinusoidal Impulse Response	15g, pulse duration 11ms, three times in each direction of X, Y, Z axis	GB/T 114537-1993, IEC60255-21-2
Sinusoidal Impact Endurance Test		
Packaging Drop	1m, one corner, three edges and six sides	GB2423.8, IEC68-2-32

Mechanical Specifications

Case Material	Metal (AL5052)
Dimensions	127.00mm x 63.00mm x 124.00mm
Weight	980g (Typ.)
Cooling Method	Free air convection

Electromagnetic Compatibility (EMC)

Emissions	CE	CISPR32/EN55032	CLASS B	
	RE	CISPR32/EN55032	CLASS B	
	Harmonic current	IEC/EN61000-3-2	perf. Criteria A	
	Voltage flicker	IEC/EN61000-3-3	Fulfilled	
Immunity*	ESD	IEC/EN61000-4-2	Contact ±8KV/Air ±15KV	perf. Criteria A
	RS	IEC/EN61000-4-3	20V/m	perf. Criteria A
	EFT (Input)	IEC/EN61000-4-4	±4KV	perf. Criteria A
	EFT (Output)	IEC/EN61000-4-4	±2KV	perf. Criteria A
	EFT (DC OK)	IEC/EN61000-4-4	DC_OK to PE ±2KV	perf. Criteria A
	Surge (Input)	IEC/EN61000-4-5	line to line ±2KV/line to PE ±4KV	perf. Criteria A
	Surge (Output)	IEC/EN61000-4-5	line to line ±500V/line to PE ±1KV	perf. Criteria A
	Surge (DC OK)	IEC/EN61000-4-5	DC OK to PE ±1KV	perf. Criteria A
	CS	IEC/EN61000-4-6	20 Vr.m.s	perf. Criteria A
	Voltage dips, short interruptions and voltage variations immunity	IEC/EN61000-4-11	0% 70%	perf. Criteria A
	Power frequency magnetic field	IEC/EN61000-4-8	30A/m	perf. Criteria A
	Intercom interference test	MS-SOP-DQC-007		perf. Criteria A

Note:* output voltage accuracy within 5%, in accordance with perf. Criteria A standards.

Note: 1. *perf. Criteria:

A: The equipment shall continue to operate as intended without operator intervention;

B: After the test, the equipment shall continue to operate as intended without operator intervention;

C: Loss of function is allowed, provided the function is self-recoverable, or can be restored by the operation of the controls by the user in accordance with the manufacturer's instructions;

Product Characteristic Curve

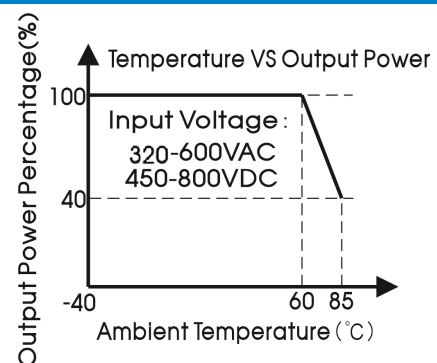
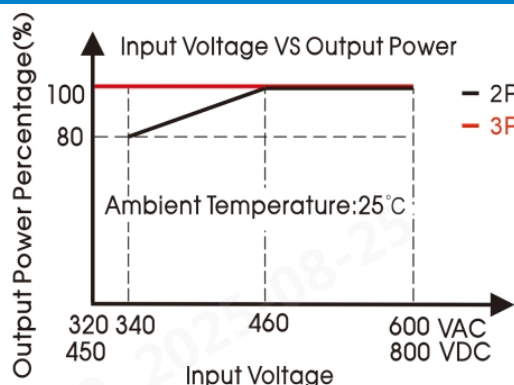

- Note: 1. All curves are for 24V output, measured at input 3x400VAC, 50Hz, output I_o, ambient temperature 25°C, unless otherwise stated;
 2. With input voltage in case of phase loss between 340 - 460VAC, the output power must be derated as per the temperature derating curves;
 3. This product is suitable for applications using natural air cooling, for applications in closed environment please consult Mornsun's FAE;
 4. The operating temperature and the ambient temperature are determined according to the air temperature at 2cm below the power supply.

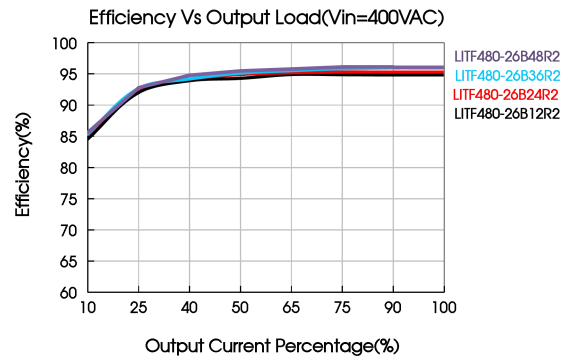
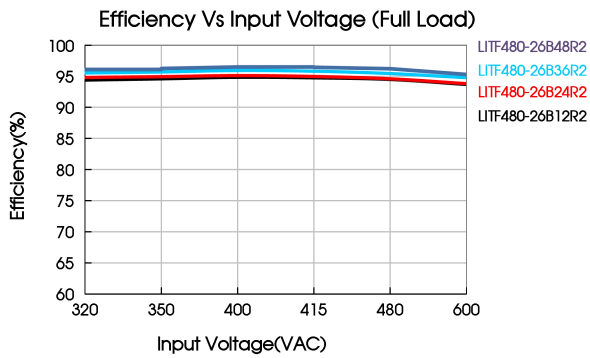

Installation Diagram

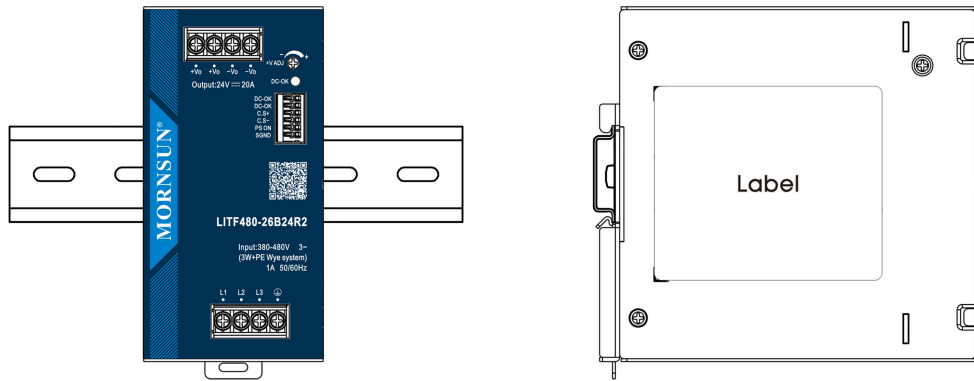

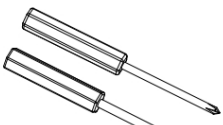
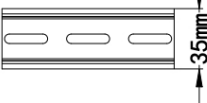
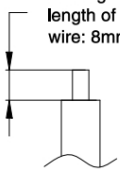
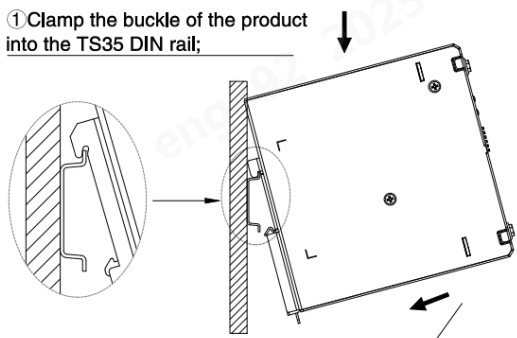
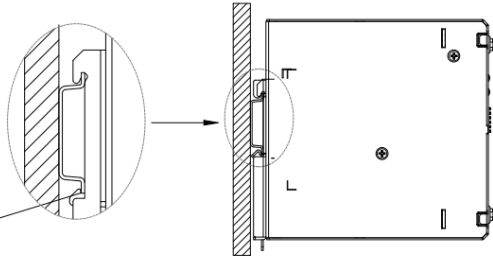
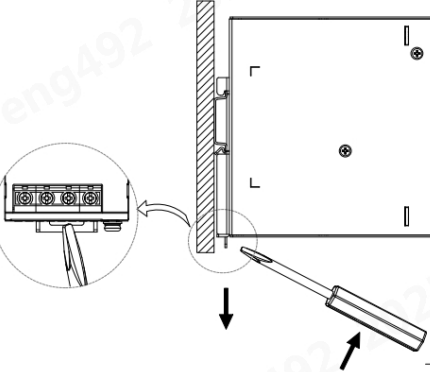
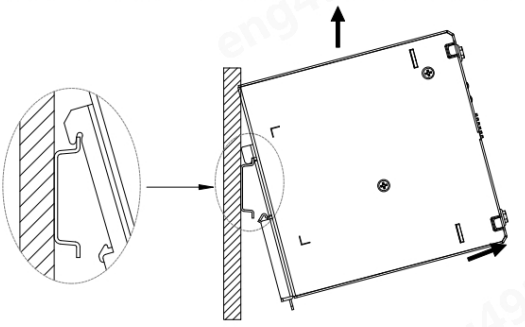
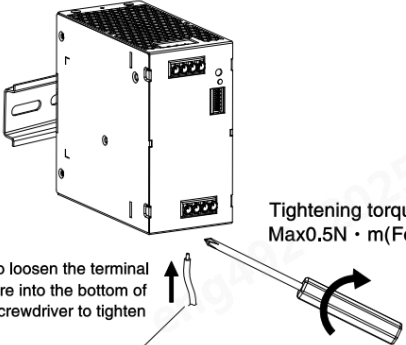
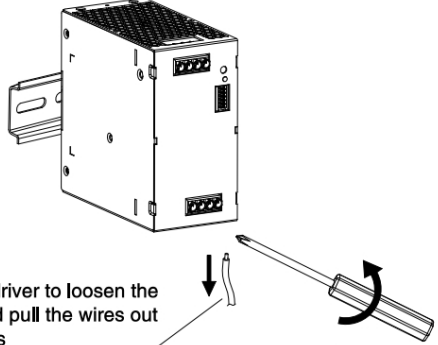

Note: Keep the following installation clearances: 20mm on top, 20mm on the bottom, 5mm on the left and right sides are recommended when the device is loaded permanently with more than 50% of the rated power. Increase this clearance to 15mm in case the adjacent device is a heat source (e.g. another power supply).

Materials required in the installation						
1	Product	1 PC	 <p>Product</p>	 <p>Phillips screwdriver Slotted screwdriver Diameter of the cutting Diameter: 3mm</p>	 <p>TS35/7.5 or TS35/15</p>	 <p>Peeling length of the wire: 8mm</p> <p>22-10AWG Wire</p>
2	Phillips screwdriver Slotted screwdriver	1 PC				
3	TS35/7.5 or TS35/15	1 PC				
4	22-10AWG Wire	/ PCS				
<p>4 The content is for reference only. Regarding the actual wire diameter and tightening torque, refer to the dimensional drawing.</p>						
Installation Steps ①-②						
<p>① Clamp the buckle of the product into the TS35 DIN rail;</p>  <p>② Push the product vertically towards the TS35 DIN rail until hearing the sound of the buckle snapping into it.</p> 						
Disassembly Steps ③-④						
 <p>③ After inserting the Slotted screwdriver into the square groove at the bottom of the buckle, push the slider of the buckle downward in the direction shown in the figure.</p>  <p>④ Hold the bottom of the product and push it outwards, then lift the product up to take the product out of the DIN rail.</p>						
Wiring / Unwiring Steps ⑤-⑥						
 <p>⑤ Use the Phillips screwdriver to loosen the terminal screws, insert the head of the wire into the bottom of the terminal, and then turn the screwdriver to tighten the terminal screws.</p> <p>Tightening torque: Max0.5N · m(For reference);</p>  <p>⑥ The Phillips screwdriver to loosen the terminal screws and pull the wires out of the terminal holes</p>						

Dimensions and Recommended Layout

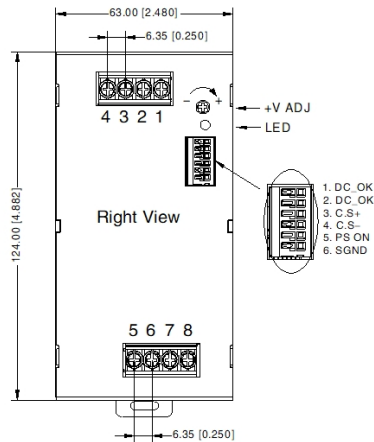
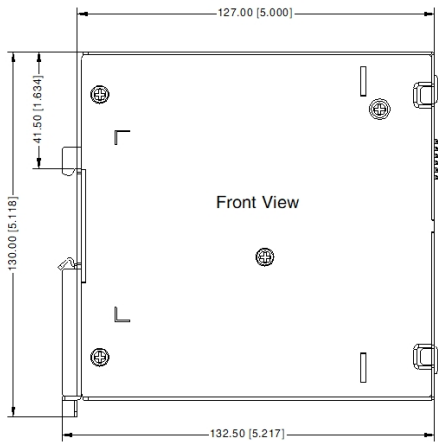
THIRD ANGLE PROJECTION 



Pin-Out	
Pin	Mark
1	-Vo
2	-Vo
3	+Vo
4	+Vo
5	L1
6	L2
7	L3
8	

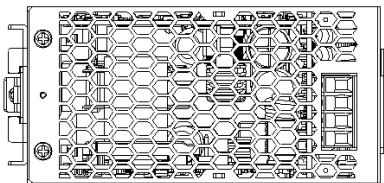

Note:

Unit: mm[inch]

ADJ: Output adjustable resistor

Wire range: Input: 22-10AWG

Output: 12V 10AWG

24V 14-10AWG

36V 16-10AWG

48V 18-10AWG

Signal: 22-18AWG

Input Tightening torque: 0.5 N·m ± 10%

Output Tightening torque: 0.5 N·m ± 10%

Mounting rail: TS35, rail needs to connect safety ground

General tolerances: ± 1.00 [± 0.039]



WARNING Risk of electrical shock, fire, personal injury or death:

AVERTISSEMENT AVERTISSEMENT Risque de choc électrique, d'incendie, de blessures corporelles ou de décès :

1. Do not use the power supply without proper grounding (Protective Earth). Use the terminal on the input block for earth connection and not one of the screws on the housing;
N'utilisez pas l'alimentation électrique sans mise à la terre appropriée (Terre protectrice). Utilisez le terminal sur le bloc d'entrée pour la connexion terrestre et non pas une des vis sur le boîtier;
2. Turn power off before working on the device, protect against inadvertent re-powering;
Éteignez l'alimentation avant de travailler sur l'appareil, protégez-vous contre la réénergisation accidentelle;
3. Make sure that the wiring is correct by following all local and national codes;
Assurez-vous que le câblage est correct en suivant tous les codes locaux et nationaux;
4. Do not modify or repair the unit;
Ne modifiez pas ou ne réparez pas l'appareil;
5. Do not open the unit as high voltages are present inside;
Ne modifiez pas ou ne réparez pas l'appareil;
6. Use caution to prevent any foreign objects from entering the housing;
Faire preuve de prudence pour empêcher les objets étrangers d'entrer dans le logement;
7. Do not use in wet locations or in areas where moisture or condensation can be expected;
Faire preuve de prudence pour empêcher les objets étrangers d'entrer dans le logement;
8. Do not touch during power-on, and immediately after power-off, hot surfaces may cause burns; 
Ne touchez pas pendant l'alimentation et, immédiatement après l'alimentation, les surfaces chaudes peuvent causer des brûlures.
9. Use copper conductors only;
N'utiliser que des conducteurs en cuivre;
10. OPEN EQUIPMENT: Adequate protection against contact with live parts and ingress of dust and water must be ensured through installation in a suitable enclosure (e.g. control cabinet, control box console or similar).

Note:

1. For additional information on Product Packaging please refer to www.mornsun-power.com, Packaging bag number: 58220850;
2. Unless otherwise specified, parameters in this datasheet were measured under the conditions of $T_a=25^{\circ}\text{C}$, humidity<75%RH with nominal input voltage and rated output load;
3. The room temperature derating of $5^{\circ}\text{C}/1000\text{m}$ is needed for operating altitude greater than 2000m;
4. All index testing methods in this datasheet are based on our company corporate standards;
5. In order to improve the efficiency at high input voltage, there will be audible noise generated, but it does not affect product performance and reliability;
6. We can provide product customization service, please contact our technicians directly for specific information;
7. Products are related to laws and regulations: see "Features" and "EMC";
8. The out case needs to be connected to the earth(\oplus)of system when the terminal equipment in operating;
9. The output voltage can be adjusted by the ADJ, clockwise to increase;
10. Our products shall be classified according to ISO14001 and related environmental laws and regulations, and shall be handled by qualified units;
11. The power supply is considered a component which will be installed into a terminal equipment. All EMC tests should be confirmed with the final equipment. Please consult our FAE for EMC test operation instructions.

Mornsun Guangzhou Science & Technology Co., Ltd.

Address: No. 8 Nanyun 4th Road, Huangpu District, Guangzhou, China

Tel: 86-20-38601850

Fax: 86-20-38601272

E-mail: info@mornsun.cn

www.mornsun-power.com

MORNSUN®

MORNSUN Guangzhou Science & Technology Co., Ltd.