



## FEATURES

- Universal 3x320-600VAC or 450-800VDC Input voltage
- Active PFC, PF up to 0.95
- Operating ambient temperature range: -40°C to +85°C (60 °C full load)
- Standard DIN-Rail mounting
- High efficiency, high reliability
- LED indicator for output status
- 150% peak power lasts for 3s
- Input under-voltage protection, output short circuit, over-current, over-voltage, over-temperature protection
- Support parallel use (2+1 current sharing) and series application
- DC OK, against backflow voltage
- Double-sided conformal coating, salt-spray proof
- Operating altitude up to 5000m
- OVC III (design refer to EN61010)
- Safety according to ANSI/ISA 71.04-2013 G3
- Design refer to UL/EN/IEC/BS EN62368, UL/EN61010, UL508

LITF240-26Bxx Series is Mornsun AC-DC three-phase Din-Rail switching power supply. It features cost-effective, high efficiency and high reliability. With 150% power reserve, enough to support starting DC motor or capacitive load and other heavy load. These converters offer excellent EMC performance and meet UL/EN/IEC/BS EN62368, UL/EN61010, UL508 standards and they are widely used in areas of industrial control equipment, factory automation and mechanical and electrical equipment and other industrial control fields.

## Selection Guide

Certification	Part No.	Output Power (W)	Nominal Output Voltage and Current (Vo/Io)	Output Voltage Adjustable Range (V)	Efficiency at 400VAC (%) Typ.	Max. Capacitive Load (μF)
/	LITF240-26B24	240	24V/10A	24-28	95	10000
	LITF240-26B48		48V/5A	48-56	95	10000

## Input Specifications

Item	Operating Conditions		Min.	Typ.	Max.	Unit
Input Voltage Range	Rated input (Certified voltage)		380	--	480	VAC
	AC input		320	--	600	
	DC input		450	--	800	VDC
Input Voltage Frequency			47	--	63	Hz
Input Current	400VAC/480VAC		--	--	0.6	A
Inrush Current	400VAC/480VAC	Cold start	--	7	--	
Power Factor	400VAC	Normal temperature, rated load	0.92	0.95	--	--
	480VAC		0.92	0.94	--	
Input Under-voltage Protection	Under-voltage protection start		200	--	--	VAC
	Under-voltage protection release		--	--	273	
Leakage Current	480VAC		<0.5mA			
Hot Plug			Unavailable			

Output Specifications

Item	Operating Conditions	Min.	Typ.	Max.	Unit
Output Voltage Accuracy	Full load range	--	±1	--	%
Line Regulation	Rated load	--	±0.5	--	
Load Regulation	400VAC	--	±0.5	--	
Ripple & Noise*	Room temperature, 400VAC, 20MHz bandwidth (peak-to-peak value)	--	50	100	mV
Temperature Coefficient		--	--	±0.03	%/°C
Minimum Load		0	--	--	%
Dynamic minimum Load		10	--	--	%
Standby power	Room temperature, 400VAC input	--	5	7	W
	Room temperature, 480VAC input	--	6	8	
Hold-up Time	400VAC/480VAC	22	--	--	ms
Short Circuit Protection		Enter hiccup mode after constant current operation for 3s (typ.), continuous, self-recovery			
Over-current Protection		≥ 130% Io, enter hiccup mode after constant current operation for 3s (typ.), self-recovery			
Over-voltage Protection	24V	≤35V	Hiccup, self-recover		
	48V	≤63V			
Over-temperature Protection	Over-temperature Protection start	--	--	90	°C
	Over-temperature Protection release	65	--	--	

Note: 1.\*The "Tip and barrel method" is used for ripple and noise test, output parallel 47uF electrolytic capacitor and 0.1uF ceramic capacitor, please refer to Enclosed Switching Power Supply Application Notes for specific information;  
2.\*Full input voltage at room temperature, <5%Io range, <250mv (Max.).

General Specifications

Item	Operating Conditions	Min.	Typ.	Max.	Unit	
Isolation	Input - output	4000	--	--	VAC	
	Input - ⊕	2500	--	--		
	Output - ⊕	500	--	--		
	Output - DC OK	500	--	--		
Insulation Resistance	Input - output	50	--	--	MΩ	
	Input - ⊕					
	Output - ⊕					
Operating Temperature		-40	--	85	°C	
Storage Temperature		-40	--	85		
Operating Humidity	Non-condensing	--	--	95	%RH	
Power Derating	Operating temperature derating	-40°C to -30°C	8.0	--	--	% / °C
		+60°C to +70°C	2.5	--	--	
		+70°C to +85°C	4.67	--	--	
	Input voltage derating	320VAC - 350VAC	0.667	--	--	%/VAC
Safety Standard		Design refer to UL/EN/IEC/BS EN62368-1, UL/EN61010-1, EN61010-2-201, UL508				
MTBF	MIL-HDBK-217F@25°C	≥300,000 h				

Environmental Characteristics

Item	Operating Conditions	Standard
Sinusoidal Vibration	10 - 200Hz, 2g, three directions of X, Y, Z axis	GB2423.10, IEC60068-2-6

Mechanical Specifications

Case Material	Metal (AL5052, SPCC)
Dimensions	52.00 x 124.00 x 127.00mm
Weight	755g (Typ.)
Cooling Method	Free air convection

Electromagnetic Compatibility (EMC)

Emissions	CE	CISPR32/EN55032	CLASS B	
	RE	CISPR32/EN55032	CLASS B	
	Harmonic current	IEC/EN61000-3-2	CLASS A	
	Voltage flicker	IEC/EN61000-3-3	Fulfilled	
Immunity	ESD	IEC/EN61000-4-2	Contact ±8KV/Air ±15KV	Perf. Criteria A
	RS	IEC/EN61000-4-3	20V/m	Perf. Criteria A
	EFT (input port)	IEC/EN61000-4-4	±4KV	Perf. Criteria A
	EFT (output port)	IEC/EN61000-4-4	±2KV	Perf. Criteria A
	EFT (DC OK port)	IEC/EN61000-4-4	±2KV	Perf. Criteria A
	Surge (input port)	IEC/EN61000-4-5	Line to line ±2KV/line to PE ±4KV	Perf. Criteria A
	Surge (output port)	IEC/EN61000-4-5	Vo+ to Vo- ±500V/Vo+/Vo- to PE ±1KV	Perf. Criteria A
	Surge (DC OK port)	IEC/EN61000-4-5	DC OK to PE, ±1KV	Perf. Criteria A
	CS	IEC/EN61000-4-6	20Vr.m.s	Perf. Criteria A
	PFMF	IEC/EN61000-4-8	30A/m	Perf. Criteria A
	Voltage dips, short interruptions and voltage variations immunity	IEC/EN61000-4-11	100% dip 1 periods, 30% dip 25 periods (50Hz), 30 periods (60Hz)	Perf. Criteria A

Functional Specifications

Item	Operating Conditions		Min.	Typ.	Max.	Unit
DC OK Signal	Full input voltage range, full load range	DC OK power on	0.95Vo - Vo			
		DC OK power off	<0.90Vo			
Oring*			Support direct parallel use, achieve 2+1 parallel redundancy			
Current Sharing Accuracy**	When multiple units are connected in parallel, the sub-modules shunt more than 50% of the rated load		--	±5	--	%
LED Signal	Main output status indication	Normal output >95%	Green on			

Note: \*For all applications, please refer to LITF240-26Bxx Series Power Supply Application Notes;

\*\*When multiple units work with current sharing, the output voltage deviation of each power supply working alone shall not exceed 100mV.

Product Characteristic Curve

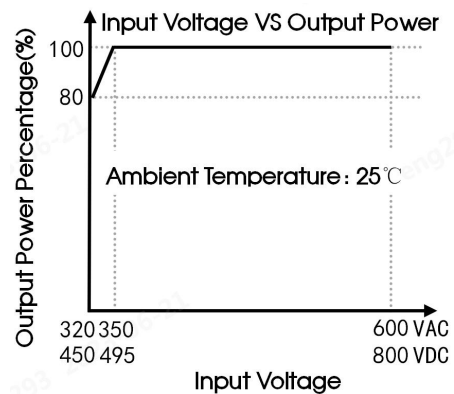
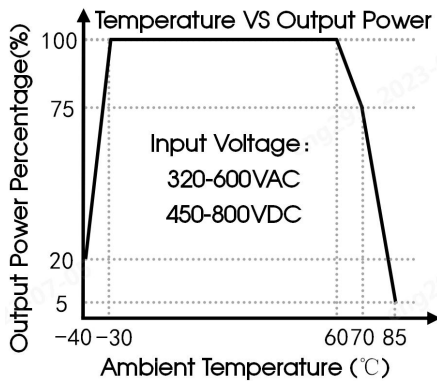

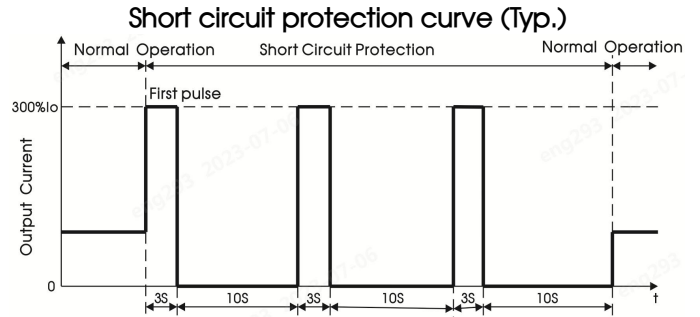
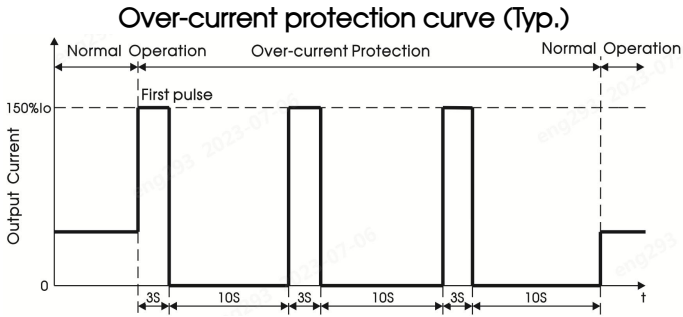

- Note: 1. With an AC input voltage between 320 - 350VAC/450 - 495VDC the output power must be derated as per the temperature derating curves;  
 2. This product is suitable for applications using natural air cooling; for applications in closed environment please consult Mornsun's FAE;  
 3. The operating temperature and the ambient temperature are determined according to the air temperature at 2cm below the power supply.

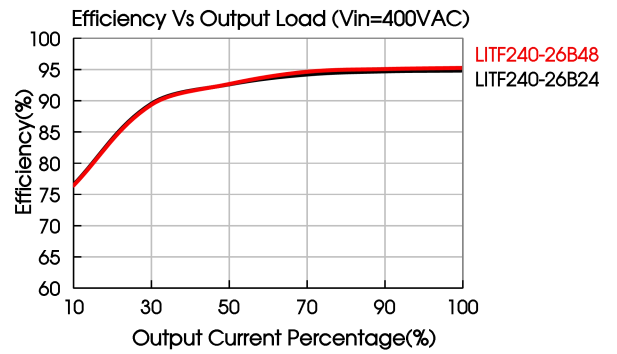
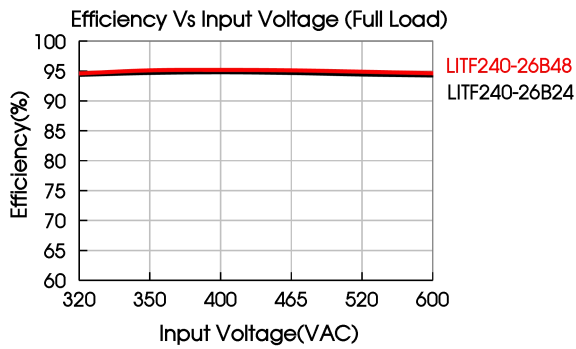

## Installation Diagram

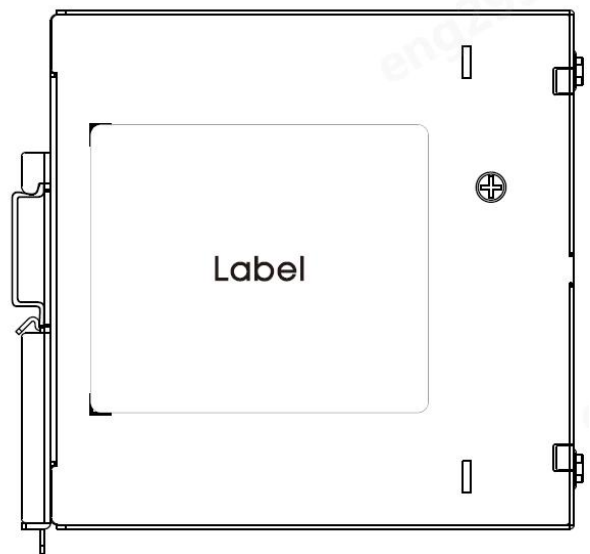
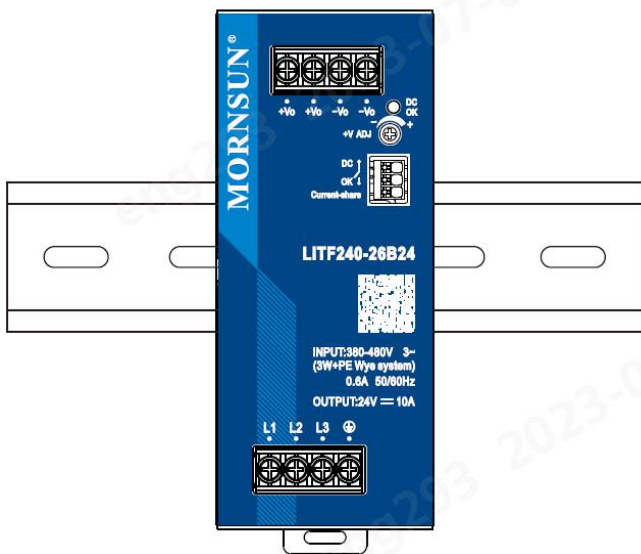

Materials required in the installation		
1	Product	1 PCS
2	Phillips screwdriver Slotted screwdriver	1 PCS
3	TS35/7.5 or TS35/15	1 PCS
4	24-10AWG wire	/ PCS
	The content is for reference only. Regarding the actual wire diameter and tightening torque, refer to the dimensional drawing.	

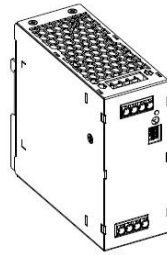

Product

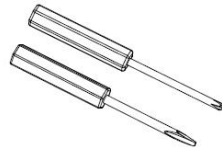

Phillips screwdriver  
Slotted screwdriver  
Diameter of the cutting  
Diameter: 3mm

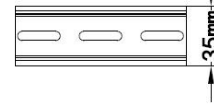

TS35/7.5 or TS35/15

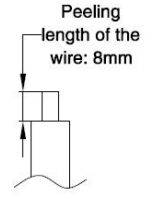

24-10AWG Wire

### Installation Steps ①-②

① Clamp the buckle of the product into the TS35 DIN rail;

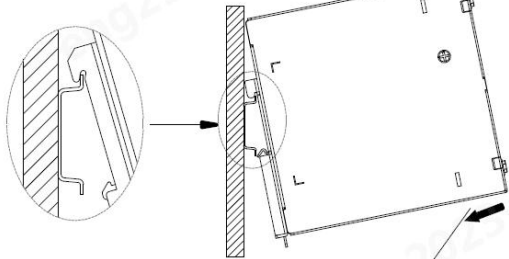

② Push the product vertically towards the TS35 DIN rail until hearing the sound of the buckle snapping into it.

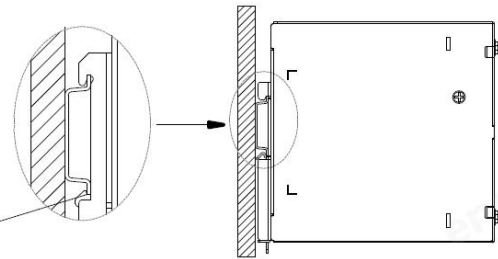

### Disassembly Steps ③-④

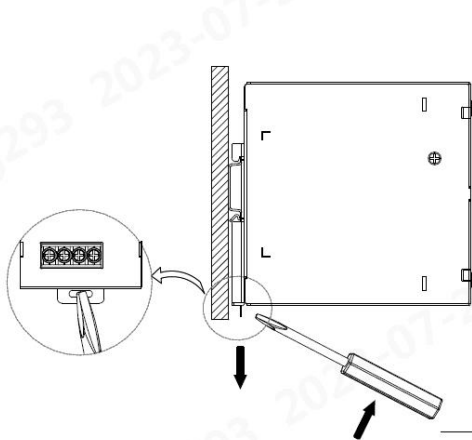

③ After inserting the Slotted screwdriver into the square groove at the bottom of the buckle, push the slider of the buckle downward in the direction shown in the figure.

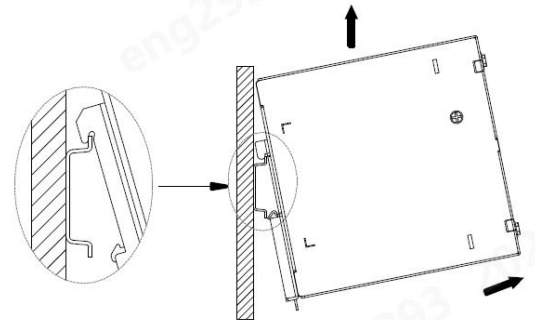

④ Hold the bottom of the product and push it outwards, then lift the product up to take the product out of the DIN rail.

### Wiring / Unwiring Steps ⑤-⑥

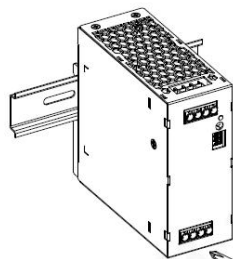

⑤ Use the Phillips screwdriver to loosen the terminal screws, insert the head of the wire into the bottom of the terminal, and then turn the screwdriver to tighten the terminal screws.

Tightening torque:  
Max0.5N · m(For reference);

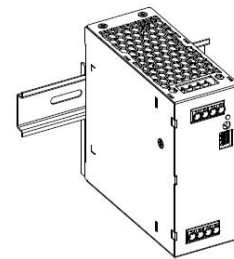



⑥ The Phillips screwdriver to loosen the terminal screws and pull the wires out of the terminal holes

Note: Keep the following installation clearances: 20mm on top, 20mm on the bottom, 5mm on the left and right sides are recommended when the device is loaded permanently with more than 50% of the rated power. Increase this clearance to 15mm in case the adjacent device is a heat source (e.g. another power supply).

Dimensions and Recommended Layout

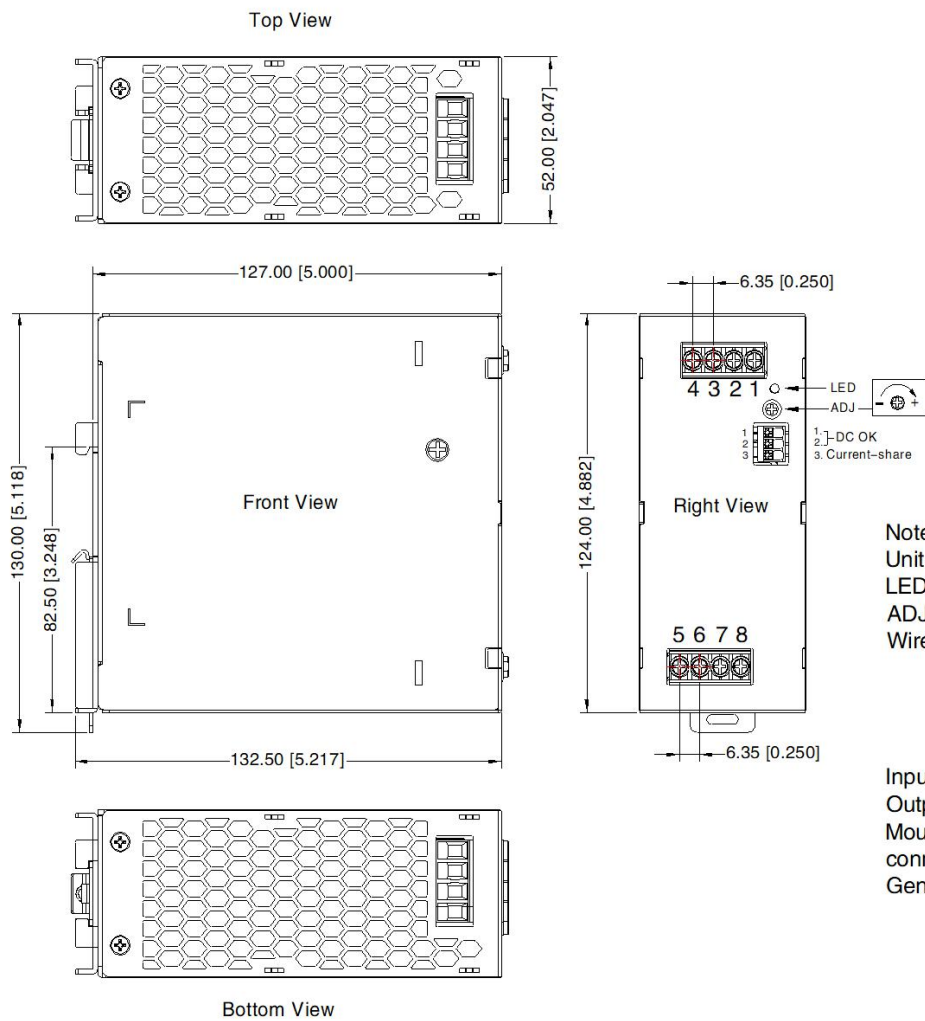
THIRD ANGLE PROJECTION 



Pin-Out	
Pin	Mark
1	-Vo
2	-Vo
3	+Vo
4	+Vo
5	L1
6	L2
7	L3
8	

**Note:**  
 Unit: mm[inch]  
 LED: Output status indicator LED  
 ADJ: Output adjustable resistor  
 Wire range: Input: 22-10 AWG  
                   (16-10AWG for pin8)  
                   Output: 24V: 16-10AWG  
                   48V: 20-10AWG  
                   DC OK: 24-16AWG  
 Input tightening torque: Max 0.5 N·m  
 Output tightening torque: Max 0.5 N·m  
 Mounting rail: TS35, rail needs to connect safety ground  
 General tolerances:  $\pm 1.00[\pm 0.039]$



**WARNING** Risk of electrical shock, fire, personal injury or death:

**AVERTISSEMENT** AVERTISSEMENT Risque de choc électrique, d'incendie, de blessures corporelles ou de décès :

1. Do not use the power supply without proper grounding (Protective Earth). Use the terminal on the input block for earth connection and not one of the screws on the housing;  
N'utilisez pas l'alimentation électrique sans mise à la terre appropriée (Terre protectrice). Utilisez le terminal sur le bloc d'entrée pour la connexion terrestre et non pas une des vis sur le boîtier;
2. Turn power off before working on the device, protect against inadvertent re-powering;  
Éteignez l'alimentation avant de travailler sur l'appareil, protégez-vous contre la réenergisation accidentelle;
3. Make sure that the wiring is correct by following all local and national codes;  
Assurez-vous que le câblage est correct en suivant tous les codes locaux et nationaux;
4. Do not modify or repair the unit;  
Ne modifiez pas ou ne réparez pas l'appareil;
5. Do not open the unit as high voltages are present inside;  
Ne modifiez pas ou ne réparez pas l'appareil;
6. Use caution to prevent any foreign objects from entering the housing;  
Faire preuve de prudence pour empêcher les objets étrangers d'entrer dans le logement;
7. Do not use in wet locations or in areas where moisture or condensation can be expected;  
Faire preuve de prudence pour empêcher les objets étrangers d'entrer dans le logement;
8. Do not touch during power-on, and immediately after power-off, hot surfaces may cause burns;   
Ne touchez pas pendant l'alimentation et, immédiatement après l'alimentation, les surfaces chaudes peuvent causer des brûlures.
9. For ambient temperature  $\leq 60^{\circ}\text{C}$ , use  $\geq 90^{\circ}\text{C}$  - copper wire only; for ambient temperature  $>60^{\circ}\text{C}$  to  $85^{\circ}\text{C}$ , use  $\geq 105^{\circ}\text{C}$  - copper wire only; use only wires with a minimum dielectric strength of 300V (input) and 60V (output);  
Température ambiante  $\leq 60^{\circ}\text{C}$ , utiliser  $\geq 90^{\circ}\text{C}$  - seulement fils de cuivre; Température ambiante  $>60^{\circ}\text{C}$  et  $85^{\circ}\text{C}$ , utiliser  $\geq 105^{\circ}\text{C}$  - seulement fils de cuivre; Uniquement pour l'utilisation de fils de cuivre d'une résistance d'isolation minimale de 300V (d'entrée) et 60V (de sortie).

Note:

1. For additional information on Product Packaging please refer to [www.mornsun-power.com](http://www.mornsun-power.com), Packaging bag number: 58220642;
2. Unless otherwise specified, parameters in this datasheet were measured under the conditions of  $T_a=25^{\circ}\text{C}$ , humidity  $<75\%RH$  with nominal input voltage and rated output load;
3. The room temperature derating of  $3.5^{\circ}\text{C}/1000\text{m}$  is needed for operating altitude greater than 2000m;
4. All index testing methods in this datasheet are based on our company corporate standards;
5. In order to improve the efficiency at high input voltage, there will be audible noise generated, but it does not affect product performance and reliability;
6. We can provide product customization service, please contact our technicians directly for specific information;
7. Products are related to laws and regulations: see "Features" and "EMC";
8. The out case needs to be connected to the earth (⊕) of system when the terminal equipment in operating;
9. The output voltage can be adjusted by the ADJ, clockwise to decrease;
10. Our products shall be classified according to ISO14001 and related environmental laws and regulations, and shall be handled by qualified units;
11. The power supply is considered a component which will be installed into a terminal equipment. All EMC tests should be confirmed with the final equipment. Please consult our FAE for EMC test operation instructions.

## Mornsun Guangzhou Science & Technology Co., Ltd.

Address: No. 5, Kehui St. 1, Kehui Development Center, Science Ave., Guangzhou Science City, Huangpu District, Guangzhou, P. R. China

Tel: 86-20-38601850

Fax: 86-20-38601272

E-mail: [info@mornsun.cn](mailto:info@mornsun.cn)

[www.mornsun-power.com](http://www.mornsun-power.com)

# LITF240-26Bxx Series Power Supply Application Notes



## Content

1. Mechanical Specification.....	10
1.1 Input Terminal (CN1).....	10
1.2 Output Terminal (CN2).....	10
1.3 Signal Connection Terminal (CN3).....	11
1.4 Green Status Display LEDS and Output Voltage Adjustment Knob.....	11
2. Function Manual.....	12
2.1 Input Requirements.....	12
2.2 Output Requirements.....	12
2.3 Starting Time.....	12
2.4 Output Over-Voltage Protection (OVP).....	12
2.5 Output Over-Current (OCP).....	13
2.6 Short Circuit Protection (SCP).....	13
2.7 Over Temperature Protection (OTP).....	14
2.8 Output Power Derating.....	14
2.9 DC OK Signal.....	14
2.10 Used In Series.....	15
2.11 Work In Parallel.....	16
2.11.1 Redundancy.....	16
2.11.2 Current Share.....	16
2.12 Available In 3-Phase 2-Wire Systems.....	18
2.13 Back Voltage Load.....	18
3. Installation Requirements.....	18
3.1 Safety Introduction.....	18
3.2 Safety Requirements.....	19
3.3 Installation Method.....	19

# 1. Mechanical Specification

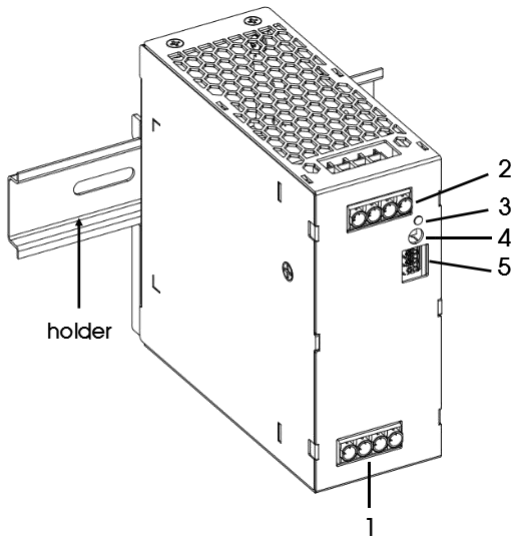

Structure Instruction	
1	Input terminal (CN1)
2	Output terminal (CN2)
3	Green status display LED lights
4	Output voltage adjustment knob
5	Signal connection terminal (CN3)

## 1.1 Input Terminal (CN1)

4 Position 6.35 mm Barrier Terminal Blocks is used as Input terminal.

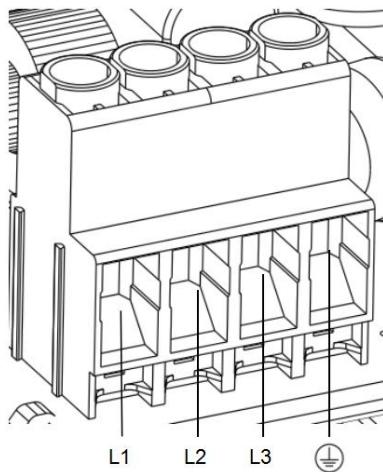

Line size: 24-10AWG  
Torque: 0.5Nm

Pin	Features
L1	Live
L2	Live
L3	Live
⊕	Protective Earth

## 1.2 Output Terminal (CN2)

4 Position 6.35 mm Barrier Terminal Blocks is used as Output terminal.

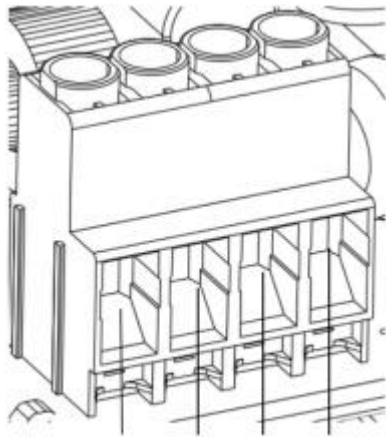

Vo- Vo- Vo+ Vo+

Line size: 24-10AWG

Torque: 0.5Nm

Pin	Features
Vo+	Positive output
Vo-	Negative output

### 1.3 Signal Connection Terminal (CN3)

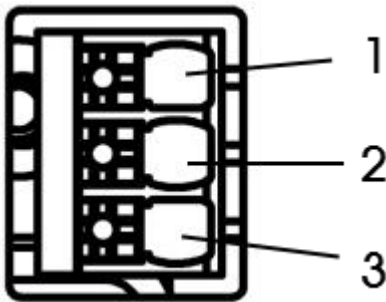

Pin	Mark	Features
1, 2	DC OK	Monitor the power supply
3	Current-share	Current sharing

### 1.4 Green Status Display LEDs and Output Voltage Adjustment Knob

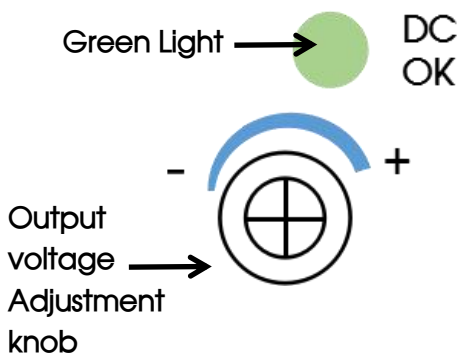

Green Light	State*
On	Normal work
Off	Power Off (No AC input)

Note: \*The LED lights indicate different working states of the power supply

Model	Rated Output Voltage	Output Voltage Adjustable Range
LITF240-26B24	24VDC	24-28VDC
LITF240-26B48	48VDC	48-56VDC

## 2. Function Manual

### 2.1 Input Requirements

The AC input voltage and DC input voltage must be within the defined amount of electricity (reference data sheet), otherwise the power supply may not work properly or even malfunction. A 600V/4A fuse has been connected in series between the L1/L2 /L3 line inside the power supply. For better protection of the module, it is recommended that customers use a circuit breaker of no more than 4A. (Just for strengthen the protective purpose, not essential requirements)

### 2.2 Output Requirements

At any output voltage value, if it is necessary to operate normally, the highest pull current and power must not exceed the rated specified value, and the output current must not exceed the maximum output current value.

### 2.3 Starting Time

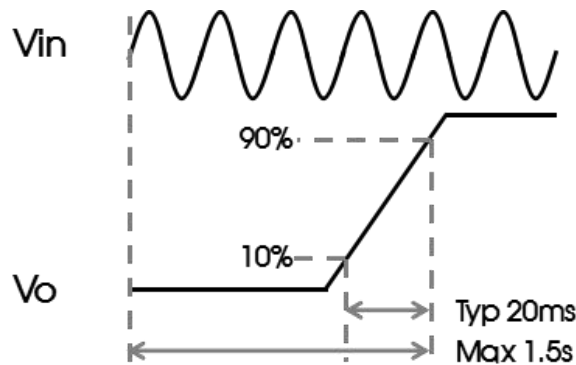

Item	Working conditions	Min.	Typ.	Max.	Unit
Start-up delay time	400VAC, full load	--	--	1.5	s

### 2.4 Output Over-Voltage Protection (OVP)

The main circuit output will be off when the output voltage reaches the over-voltage protection value. When it occurs, the output enters the hiccup mode with 10s. After the abnormal removed, the output returns to normal.

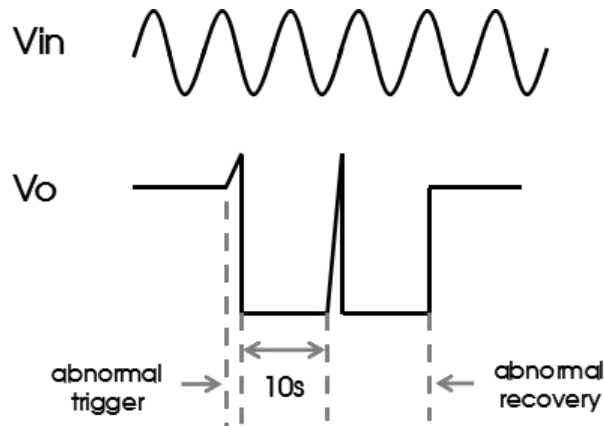

## 2.5 Output Over-Current (OCP)

When the output current exceeds 130% of the rated output current, the output will be off for 10s. And then entering the constant current mode for 3s, output voltage recovery, maintaining 150% of the rated output current. After the abnormal removed, self-recover.

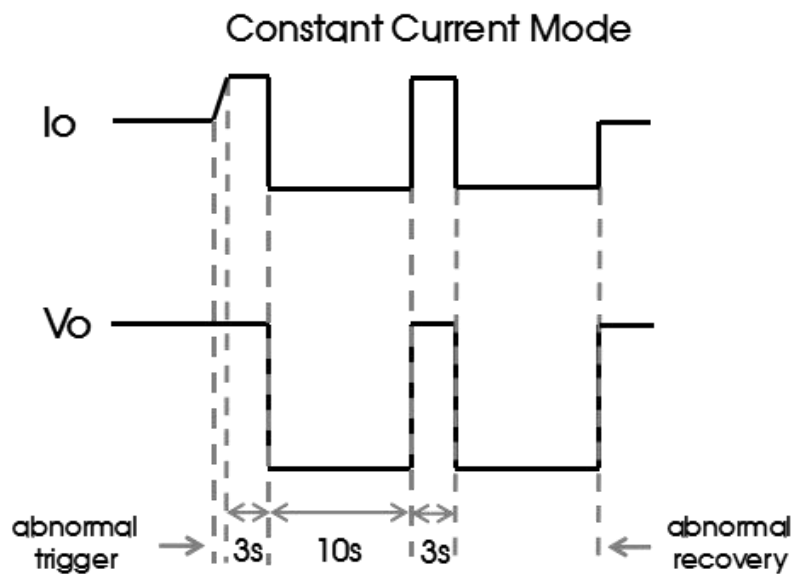

## 2.6 Short Circuit Protection (SCP)

When the output current is shorted, the output will operate in constant current mode for 3s, and then output is off for 10s, and the output enter constant current mode for 3s again. After the abnormal removed, self-recover.

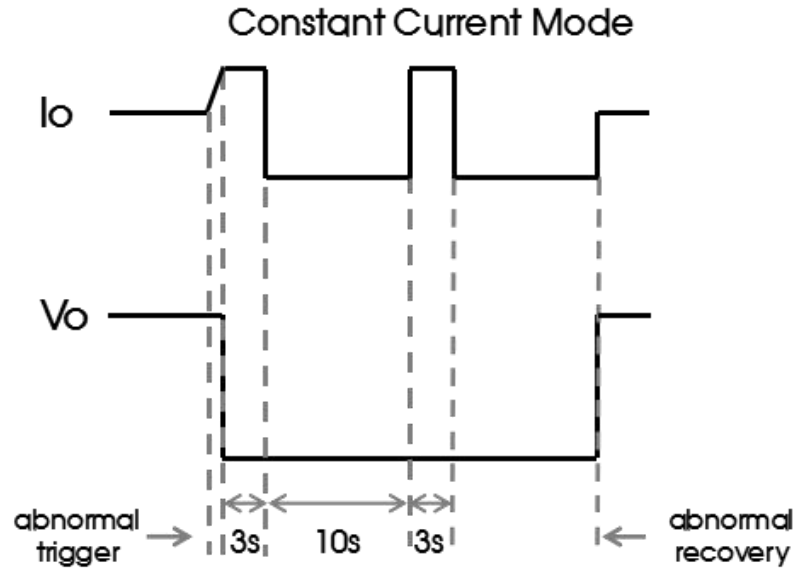

## 2.7 Over Temperature Protection (OTP)

When the ambient temperature of the power supply exceeds the rated temperature for a period of time, the power supply will turn off the output and enter the hiccup state. After the ambient temperature drops to the set value, the power supply will resume normal operation.

## 2.8 Output Power Derating

When the input voltage is greater than 350VAC (or 495VDC), only need to derate according to the temperature derating curve;

When the input voltage is lower than 350VAC (or 495VDC), the output power will be derated according to the following input voltage derating curve requirements after the temperature derating.

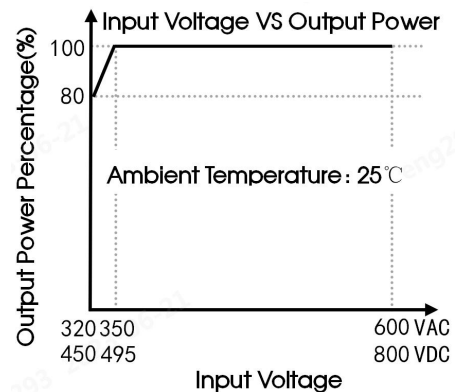
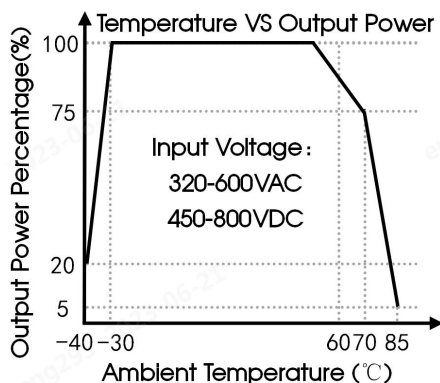

## 2.9 DC OK Signal

The DC OK signal is used to monitor whether the power supply is working normally. This signal is on the DC OK pin of the terminal CN3. When the output is greater than 95% of the rated voltage of the output,

the DC OK signal is activated, the DC OK at the terminal is connected, and the green light is on at the same time. When the output voltage is less than 90% of the rated voltage of the output, the DC OK is disconnected, and the green light is off at the same time.

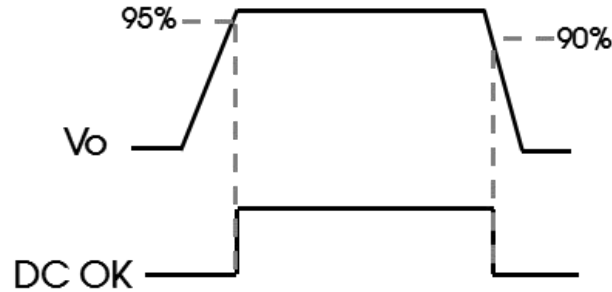

## 2.10 Used In Series

The same type of power supply can be connected in series with each other to increase the output voltage. Under the premise that the total output does not exceed 150VDC, any number of power supplies can be connected in series as needed. Voltages in excess of 60VDC are no longer considered Safety Extra Low Voltage Circuits (SELV) and can therefore be dangerous. When installing such voltages, it must be protected against touch.

Please avoid generating feedback voltage to the output terminals (eg from a decelerating motor or battery).

Keep a 15mm (left/right) installation gap between the two power supplies and avoid installing the power supplies on top of each other. Do not connect the power supplies in series in an installation orientation other than the standard installation orientation (input terminals down).

Note that leakage current, electromagnetic interference, inrush current and harmonics will increase when multiple power supplies are used.

Refer to the figure below for the wiring method:

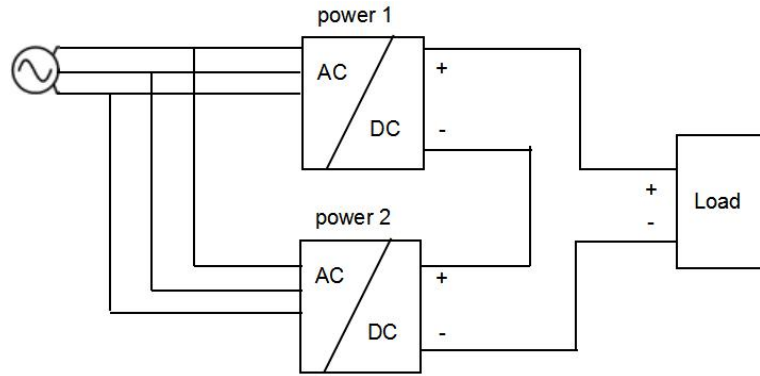

## 2.11 Work In Parallel

### 2.11.1 Redundancy

Power module outputs can be connected in parallel for redundancy, increasing system reliability. The maximum power of the redundant system needs to be de-rated to ensure that the redundant system can still meet the rated load requirements when a power supply module fails. Currently, the common practice is to build a redundant system by the N+1 method, that is, N+1 power supplies are connected in parallel. Support the maximum load current  $N \cdot I_{max}$ , where  $I_{max}$  is the rated output current of each power supply, for example, the rated output current of each power supply is 20A, and 2+1 are connected in parallel, thus constructing a  $2 \cdot 20A = 40A$  redundant system.

The power module supports 2+1 parallel redundant operation.

The Oring circuit is used inside the power module, and when any one of the power modules in parallel fails, it will not affect the work of other power modules.

### 2.11.2 Current Share

The current sharing bus (Current-share) between multiple machines is short-circuited with each other.

The output voltage difference of each single module is less than or equal to 100mV, and a better comprehensive effect of line terminal output voltage and current sharing can be obtained. The wiring method of the current sharing function is shown in the following figure:



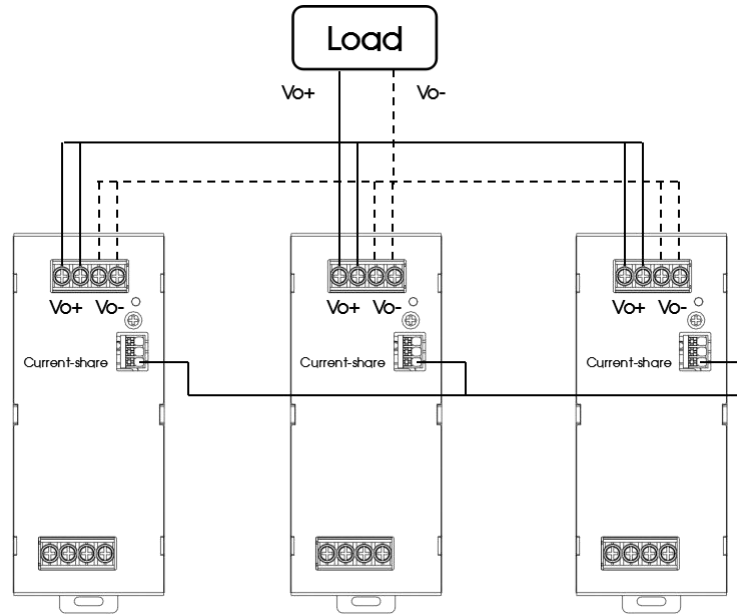

Note: 1. When used in parallel, the number of parallel modules cannot exceed 3.

2. When the power modules work in parallel, there is an active current sharing circuit inside to ensure that the current between each module remains balanced.

The active current sharing circuit adopts the automatic master-slave current sharing method. Each power supply module has a current sharing bus signal (Current-share). When working in parallel, the current sharing buses of all power modules must be connected together. The current sharing bus signal is located at pin 3 of CN3.

The output voltage of each power module will affect the current sharing accuracy. The output voltage of the power module is rated voltage  $\pm 100\text{mV}$ . In practical applications, if the output voltage value needs to be adjusted, the recommended voltage range is: target voltage value  $\pm 100\text{mV}$ .

After the output load of each power module is greater than 50% of the rated load, the current sharing accuracy is required to be  $\pm 5\%$ . The calculation formula of current sharing is:

$$\text{Power supply 1's average accuracy} = \frac{I_{o1} - (I_{o1} + I_{o2}) / 2}{(I_{o1} + I_{o2}) / 2} * 100\%$$

$$\text{Power supply 2's average accuracy} = \frac{I_{o2} - (I_{o1} + I_{o2}) / 2}{(I_{o1} + I_{o2}) / 2} * 100\%$$

$I_{o1}$ : The output current value of the power supply 1 in the parallel power module;

$I_{o2}$ : The output current value of the power supply 2 in the parallel power module.

## 2.12 Available In 3-Phase 2-Wire Systems

This power supply can also be used for permanent operation of two-wire in a three-phase system.

When operating the two-wire in a three-phase system, the output power must be derated according to the following curve, and the input operating voltage can only operate at 320VAC-600VAC. Exceeding this derating limit for a long time will cause the power supply to overheat and shut down.

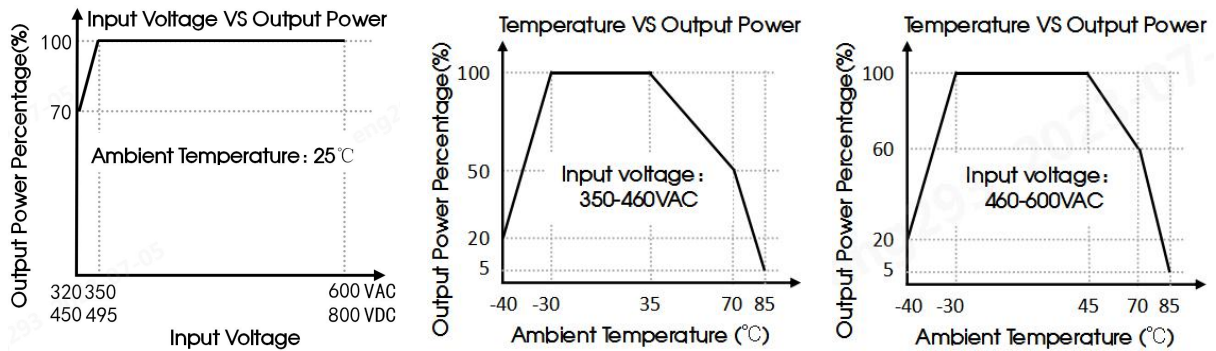

Note: Basic performance such as electromagnetic compatibility performance, hold-up time, loss and output ripple are different from three-phase operation. This working method is not covered in the certification, and operation two wires in a three-phase system does not meet the safety certification.

## 2.13 Back Voltage Load

Loads such as decelerating motors, inductors can feed voltage back into the power supply. This property is also known as feedback voltage resistance or resistance to opposing electromagnetic forces.

The power supply is resistant to voltage back into the supply by the load and will not fail regardless of whether the power supply is on or off. The function diagram as below:

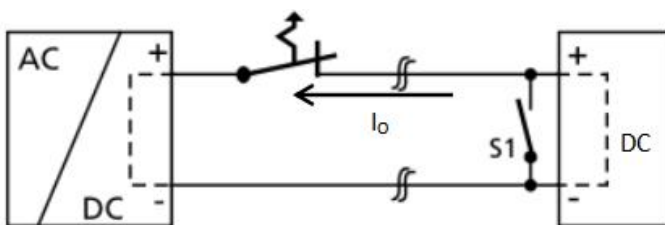

Maximum allowable feedback voltage	
Model	Maximum feedback voltage
LITF240-26B24	35VDC
LITF240-26B48	63VDC

# 3. Installation Requirements

## 3.1 Safety Introduction

**WARNING: RISK OF ELECTRIC SHOCK DURING HIGH VOLTAGE WORKING WITH THIS EQUIPMENT**

- After the power module is disconnected from the input AC or DC power, leave it for at least one minute before starting to operate it.
- When installing the input cable to the power module, first connect the ground terminal, and then connect the L1, L2 and L3 cables.
- When removing the input wire, first remove the L1 wire, L2 wire and L3 wire, and then remove the ground wire.
- When disassembling and assembling, make sure that no objects fall into the inside of the power module.
- Be careful of high temperature burns
- After the power module works in a high temperature environment, wait for its shell to cool before operating it.
- This product needs to be installed by professionals and needs to be used with other equipment.

### 3.2 Safety Requirements

When installing, pay attention to the primary side and the protective ground. The creepage distance and electrical clearance of the primary side and the secondary side meet the safety requirements, refer to EN/UL61010.

### 3.3 Installation Method

Installation direction: When installing, the port of the output end should be upward, and the port of the input end should be downward. (See below)

Note: Pay attention to the temperature rise of the device in different installation modes. Derate the device according to the actual situation.

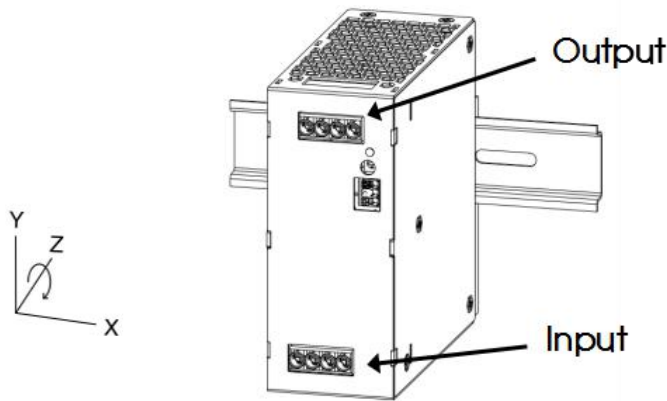
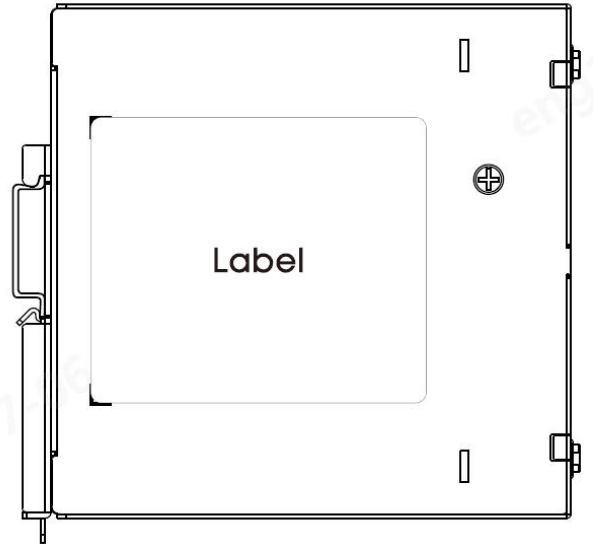
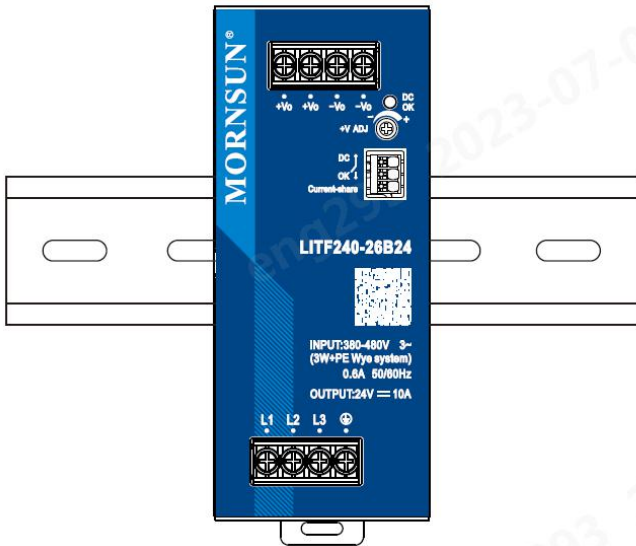

Rotate the installation position (0° Z-Axis)

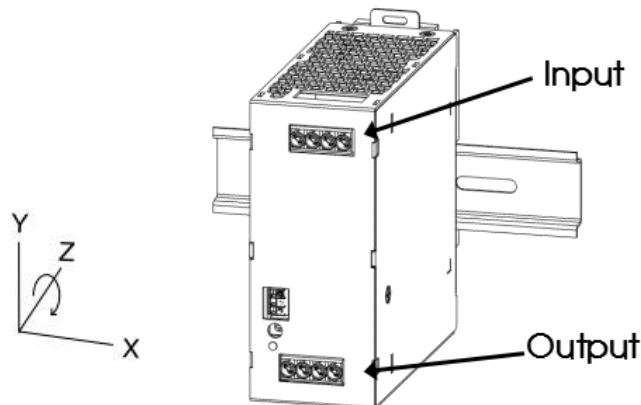
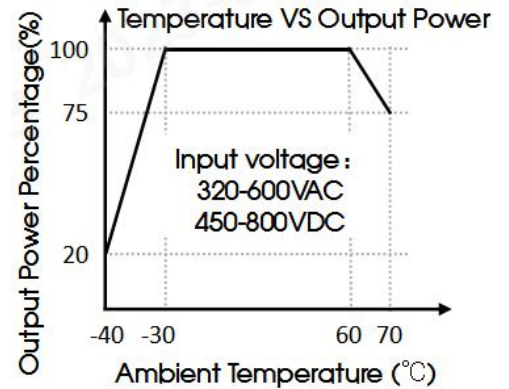

Rotate the installation position (180° Z-Axis)

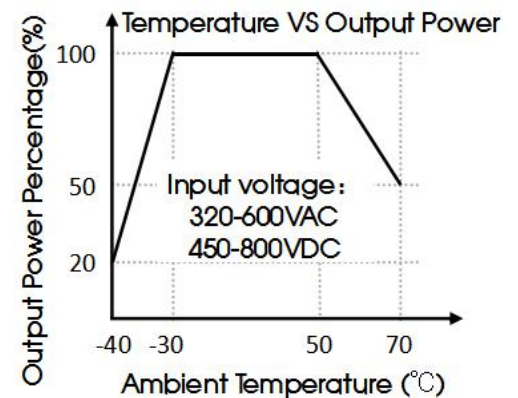

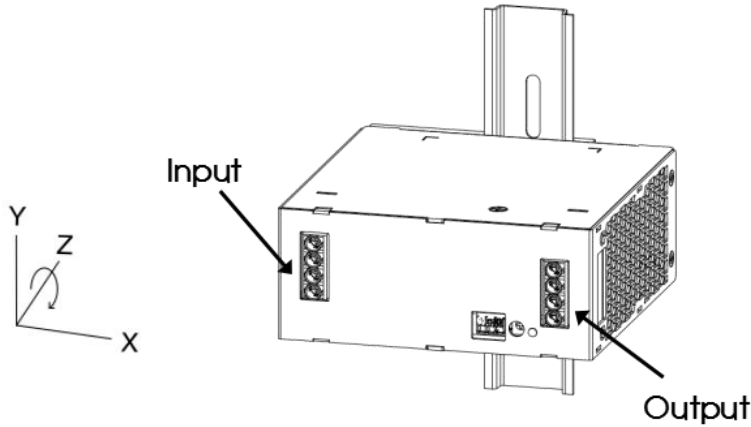

Rotate the installation position (90° Z-Axis)

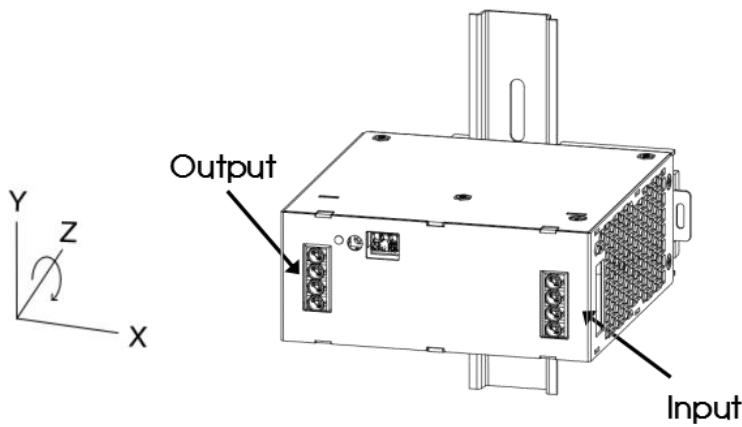

Rotate the installation position (270° Z-Axis)

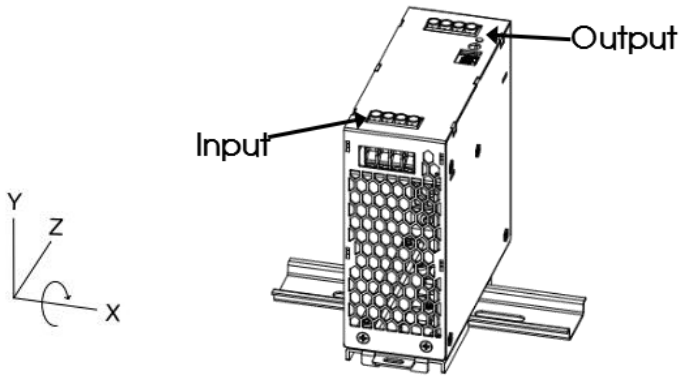

Rotate the installation position (90° X-Axis)

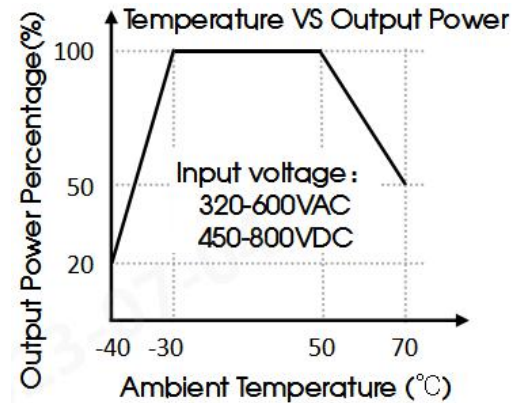
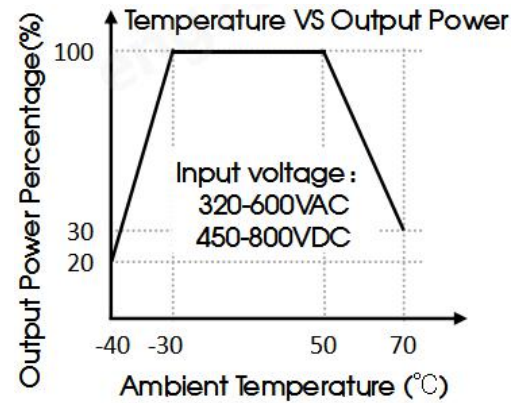
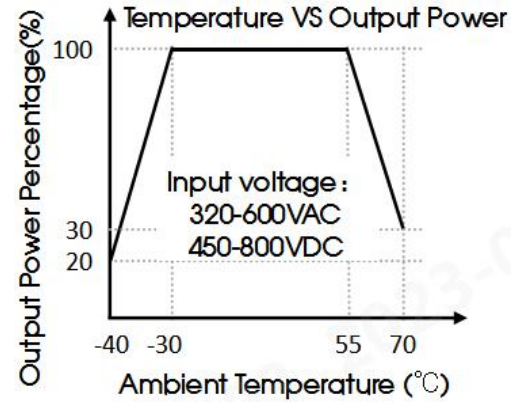

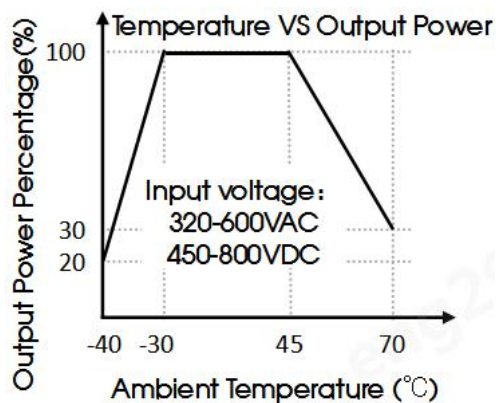
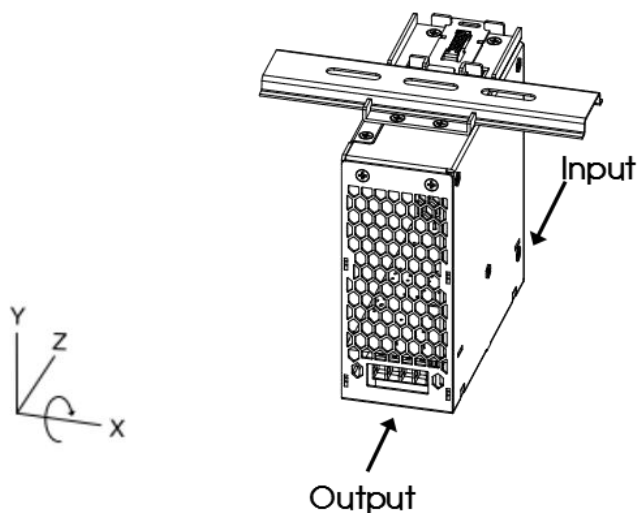

Rotate the installation position (270° X-Axis)