

Non-isolated DC-DC converter  
Ultra-wide input and buck single output



Patent Protection RoHS

## FEATURES

- Ultra-wide input voltage range: 14.5 - 85VDC
- High efficiency up to 98%
- Input under-voltage protection, output short-circuit, over-current protection, over-temperature protection
- Operating ambient temperature range: -40°C to +105°C
- Industry standard 1/8-Brick package and pin-out
- Maximum 540W output power

The KJB48xxEB(F)-20A series are high efficiency switching regulators. It features ultra-wide input range of 14.5- 85V, efficiency up to 98%, operating temperature of -40°C to +105°C, input under-voltage protection, output short-circuit and output over-current protection, over-temperature protection, remote control, output voltage regulation and remote compensation and other functions. It is widely used in robotics, communications, battery management, DC-DC distributed power supply and other occasions.

## Selection Guide

Certification	Part No. <sup>①</sup>	Input Voltage(VDC)		Output		Full Load Efficiency(%) Min./Typ. <sup>④</sup>	Capacitive Load (μF) Max.
		Nominal <sup>②</sup> (Range)	Max. <sup>③</sup> (VDC)	Voltage (VDC)	Current(A) Max.		
-	KJB4805EB(F)-20A	48 (14.5-85)	90	5	20	90/92	8500
	KJB4812EB(F)-20A	48 (18-85)		12	20	93/95	5500
	KJB4815EB(F)-20A	48 (21-85)		15	20	93/95	4400
	KJB4824EB(F)-20A	48 (30-85)		24	20	94/96	2200
	KJB4836EB(F)-15A	48 (43-85)		36	15	96/98	680

Notes:  
 ① "F" means heat sink package; We recommend to choose modules with a heat sink for enhanced heat dissipation and applications with extreme temperature requirements;  
 ② After KJB4805EB(F)-20A is started with 16VDC input voltage, it can drop to 14.5VDC input voltage to work, but the 14.5-16VDC input voltage range is not guaranteed to meet the specifications in this manual. This manual specifications based on 16-85VDC input voltage range; When the input voltage exceeds 48VDC, a 330μF/100V electrolytic capacitor needs to be connected to the input to prevent module damage caused by voltage spikes;  
 ③ The input voltage should not exceed this value, otherwise permanent and unrecoverable damage may be caused;  
 ④ The above efficiency values are measured at nominal 48VDC input voltage.

## Input Specifications

Item	Operating Conditions	Min.	Typ.	Max.	Unit	
Input Current (full load / no-load)	Nominal 48VDC input	KJB4805EB(F)-20A	--	2265/2	2315/--	mA
		KJB4812EB(F)-20A	--	5264/2	5377/--	
		KJB4815EB(F)-20A	--	6579/2	6721/--	
		KJB4824EB(F)-20A	--	10417/2	10639/--	
		KJB4836EB(F)-15A	--	11480/2	11719/--	
Reverse Polarity at Input	Nominal 48VDC input	--	300	--		
Surge Voltage (1sec. max.)		--	--	90		
Start-up Voltage	KJB4805EB(F)-20A	--	--	16	VDC	
	KJB4812EB(F)-20A	--	--	18		

Start-up Voltage	KJB4815EB(F)-20A	--	--	21	VDC
	KJB4824EB(F)-20A	--	--	30	
	KJB4836EB(F)-15A	--	--	43	
Under-voltage Protection	KJB4805EB(F)-20A	10	--	--	
	KJB4812EB(F)-20A	13	--	--	
	KJB4815EB(F)-20A	16	--	--	
	KJB4824EB(F)-20A	24	--	--	
	KJB4836EB(F)-15A	36	--	--	
Input Filter		Capacitance filter			
Hot Plug		Unavailable			
Input Reverse Polarity Protection		Unavailable			
Ctrl*	Module on	Ctrl pin open or pulled high(TTL 3 - 20VDC)			
	Module off	Ctrl pin pulled low to -Vin(0 - 1VDC)			
	Input current when off	--	1	5	mA

Note: \*The "ctrl" pin voltage is referenced to input "-Vin".

## Output Specifications

Item	Operating Conditions	Min.	Typ.	Max.	Unit
Voltage Accuracy	Input voltage range, 10% - 100%Io	--	±2	±3	%
Linear Regulation	Full load, input voltage range	--	±0.3	±1	
Load Regulation	Nominal 48VDC input, 10% - 100%Io	--	±0.5	±2	
Transient Recovery Time	Nominal 48VDC input, 25% load step change	--	300	500	us
Transient Response Deviation	Nominal 48VDC input, 25% load step change	5VDC output	--	±8	%
		Others	--	±5	
Temperature Coefficient	Operating temperature -40℃ to +105℃, full load	--	±0.02	--	%/℃
Ripple & Noise <sup>①</sup>	20MHz bandwidth, nominal 48VDC input, full load	--	250	350	mVp-p
Over-temperature Protection <sup>②</sup>	Maximum surface temperature of the product	--	125	--	℃
Over-current Protection	Normal temperature, input voltage range	110	130	230	%Io
Short-circuit Protection	Input voltage range	Hiccup, continuous, self-recovery			

Notes: ① The method is used for ripple and noise test, please refer to Fig.3 and DC-DC Converter Application Notes for specific information;  
② Over-temperature protection for product is output off.

## General Specifications

Item	Operating Conditions	Min.	Typ.	Max.	Unit
Trim <sup>①</sup>		90	--	110	%Vo
Sense <sup>①</sup>	See part of Remote Sense Application	--	--	105	
Operating Temperature		-40	--	+105	℃
Storage Temperature		-55	--	+125	
Pin Soldering Resistance Temperature	Wave-soldering, 10 second	--	--	260	
Storage Humidity	Non-condensing	5	--	95	%RH
Vibration		10-150Hz, 5g, 0.75mm, 90 Min. along X, Y and Z			
Switching Frequency <sup>②</sup>		--	350	--	kHz
MTBF	MIL-HDBK-217F@25℃	1000	--	--	k hours

Notes: ① When using Trim and Sense, the 24VDC output needs to meet Vin ≥ 34VDC, the 36VDC output needs to meet Vin ≥ 48VDC;  
② Switching frequency varies with input voltage and load, ranging from 110-750 kHz.

## Mechanical Specifications

Case Material	Aluminum alloy
---------------	----------------

Dimensions	KJB48xxEB-20A,KJB4836EB-15A	60.80 x 25.00 x 12.70 mm
	KJB48xxEBF-20A,KJB4836EBF-15A	60.80 x 36.83 x 12.70 mm
Weight	KJB48xxEB-20A,KJB4836EB-15A	53.0g(Typ.)
	KJB48xxEBF-20A,KJB4836EBF-15A	58.2g(Typ.)
Cooling Method	Free air convection or forced convection	

### Electromagnetic Compatibility (EMC)

Emissions	CE	CISPR32/EN55032	CLASS A (see Fig. 4 for recommended circuit)	
	RE	CISPR32/EN55032	CLASS A (see Fig. 4 for recommended circuit)	
Immunity	ESD	IEC/EN61000-4-2	Contact ±6kV	perf. Criteria B
	RS	IEC/EN61000-4-3	10V/m	perf. Criteria A
	EFT	IEC/EN61000-4-4	±2kV (see Fig. 4 for recommended circuit)	perf. Criteria A
	Surge	IEC/EN61000-4-5	line to line ±2kV (see Fig. 4 for recommended circuit)	perf. Criteria B
	CS	IEC/EN61000-4-6	10Vr.m.s	perf. Criteria A

### Typical Characteristic Curves

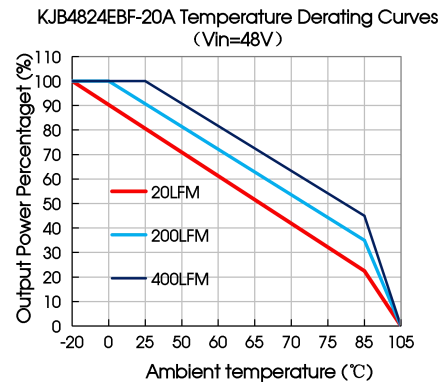
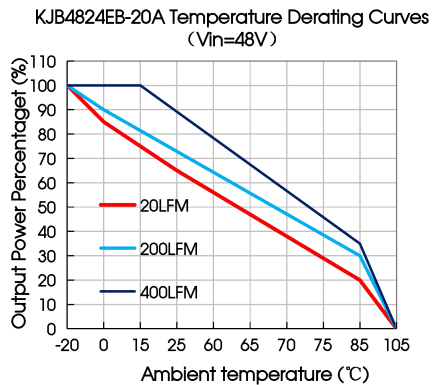
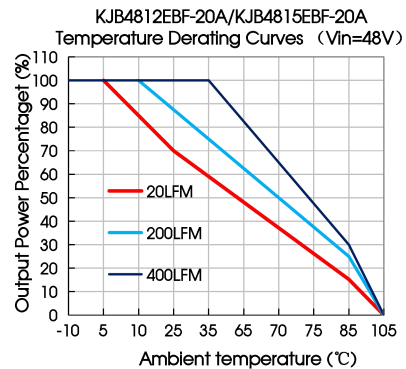
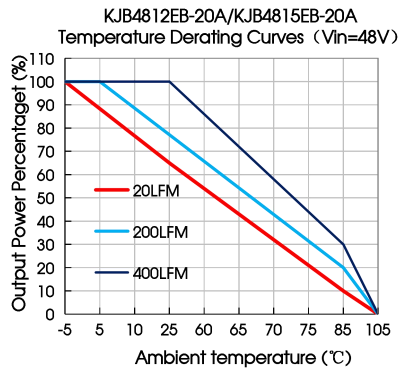
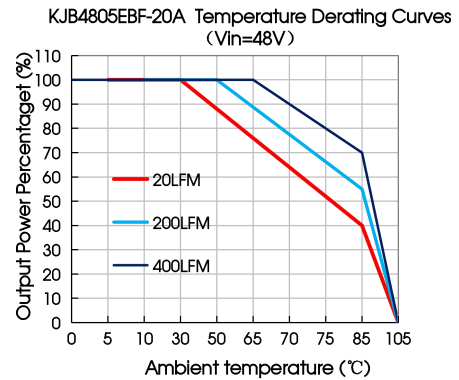
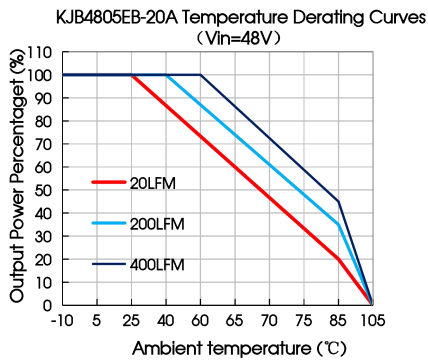

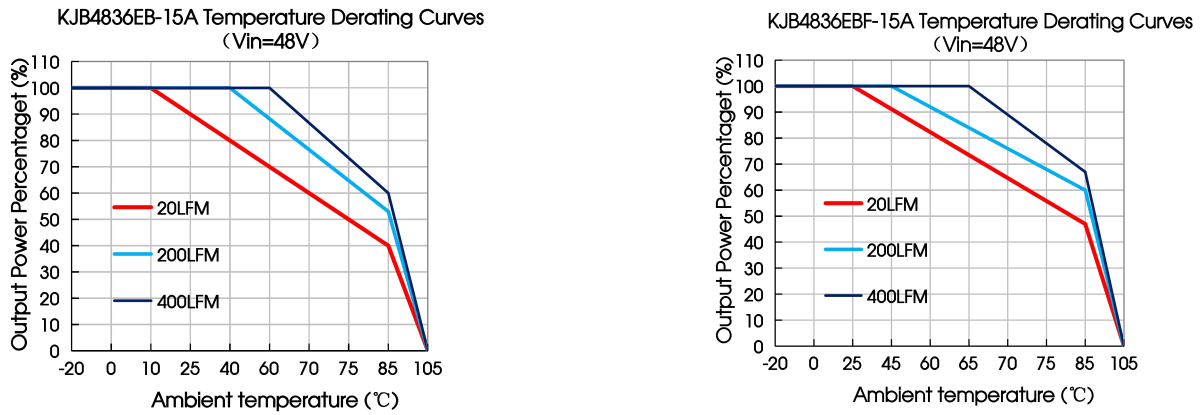

Fig. 1

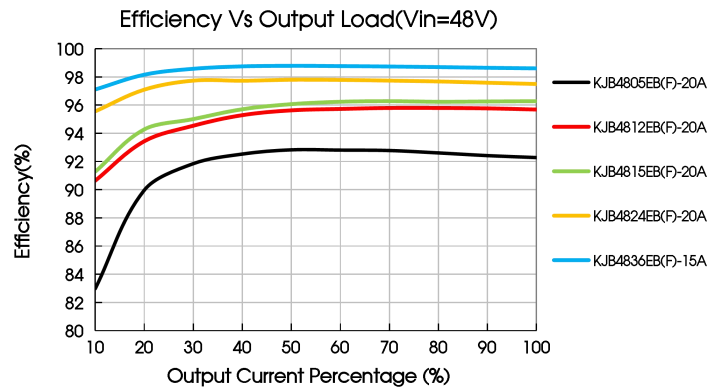
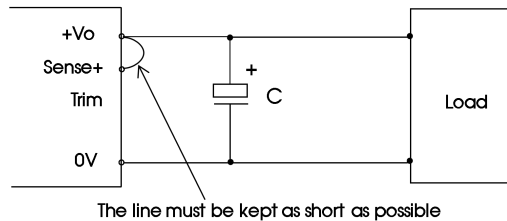

Fig. 2

## Remote Sense Application

### 1. Remote Sense Application:



Notes:

- 1) If the sense function is not used for remote regulation the user must connect the Sense+ to +Vo at the DC-DC converter pins and will compensate for voltage drop across pins only.
- 2) The connections between Sense lines and their respective power lines must be kept as short as possible, otherwise they may be picking up noise, interference and/or causing unstable operation of the power module.

### 2. Remote Sense Connection used for Compensation

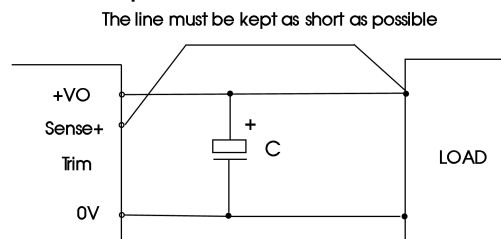

Notes:

- 1) Using remote sense with long wires may cause unstable output, please contact technical support if long wires must be used;
- 2) We recommend using adequate cross section for PCB-track layout and/or cables to connect the power supply module to the load in order to keep the voltage drop below 0.3V and to make sure the power supply's output voltage remains within the specified range;
- 3) Note that large wire impedance may cause oscillation of the output voltage and/or increased ripple. Consult technical support or factory for further advice of sense operation.

Design Reference

1. Application circuit

(1) During product testing and application, please follow the recommended test circuit (Fig. 3); At least one electrolytic capacitor  $C_{in}$  is guaranteed to be connected externally to suppress the possible input surge voltage; An external inductor and electrolytic capacitor are connected to output for output filtering;

(2) If the input terminal of the product is connected in parallel with a circuit with large transient energy (such as a parallel motor drive circuit), the input voltage of the product may be pulled down. At this time, pay attention to the fluctuation of the input voltage of the product, and it is recommended to appropriately increase the capacitance of the electrolytic capacitor  $C_{in}$  at the input terminal to ensure the stability of the input terminal voltage and avoid the situation where the input voltage is lower than the under-voltage protection point and cause the product to restart repeatedly;

(3) If the input and output ripple needs to be further reduced,  $C_{in}$  and  $C_{out}$  capacity of external capacitors can be appropriately increased or external capacitors with small series equivalent impedance can be selected.

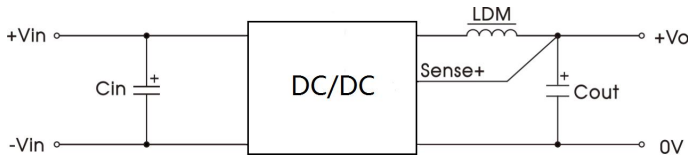

Fig. 3

$C_{in}$	LDM	$C_{out}$
330 $\mu$ F/100V(ESR<45m $\Omega$ )	1 $\mu$ H/27A	330 $\mu$ F/50V

2. EMC compliance circuit

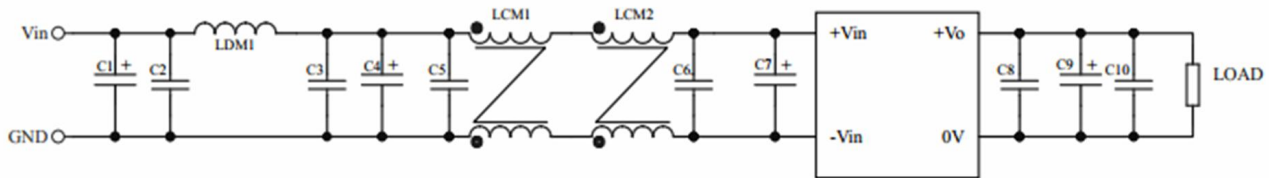
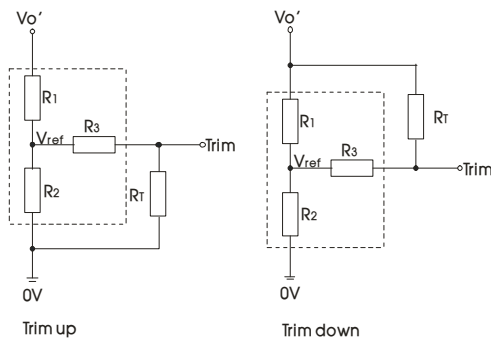

Fig. 4

Components	Recommended Component Value	Components Function
C1	2000 $\mu$ F/100V electrolytic capacitor	Meet EFT and Surge
C7	330 $\mu$ F/100V electrolytic capacitor	
C1, C4, C7	330 $\mu$ F/100V electrolytic capacitor	Meet CE and RE
C2, C3, C5, C6	4.7 $\mu$ F/100V ceramic capacitor	
C8, C10	4.7 $\mu$ F/50V ceramic capacitor	
C9	330 $\mu$ F/50V electrolytic capacitor	
LDM1	8.2uH/15A	
LCM1, LCM2	FL2D-D0-040 (MORNSUN)	

3. Trim Function for Output Voltage Adjustment



Trim resistor connection (dashed line shows internal resistor network)

Trim resistance calculation formula:

$$\begin{aligned} \text{up: } R_T &= \frac{\alpha R_2}{R_2 - \alpha} - R_3 & \alpha &= \frac{V_{ref}}{V_{o'} - V_{ref}} \cdot R_1 \\ \text{down: } R_T &= \frac{\alpha R_1}{R_1 - \alpha} - R_3 & \alpha &= \frac{V_{o'} - V_{ref}}{V_{ref}} \cdot R_2 \end{aligned}$$

$R_T$ : the Trim resistor  
 $A$ : a user-defined parameter and has no actual meaning  
 $V_{o'}$ : the actual up or down voltage required

Part No.	R1(k $\Omega$ )	R2(k $\Omega$ )	R3(k $\Omega$ )	Vref(V)
KJB4805EB(F)-20A	6.65	2.87	12.4	1.5
KJB4812EB(F)-20A	20	2.87	14.7	1.5
KJB4815EB(F)-20A	25.8	2.87	17.5	1.5
KJB4824EB(F)-20A	43.13	2.87	17	1.5
KJB4836EB(F)-15A	83.08	3.6	20.8	1.5

When trimming is used, if the RT resistor is too small or the Trim and +Vo pins are directly short-circuited, resulting in the output voltage after trimming, the product may be irreparably damaged.

4. The products do not support parallel connection of their output

5. Recommended solution for thermal test

In the application process, the product temperature derating curve can be combined to evaluate the product thermal design; The temperature of point A is used to determine the stable operating range of the product, when it is lower than 110°C, it is the stable operating range.



6. For additional information please refer to DC-DC converter application notes on [www.mornsun-power.com](http://www.mornsun-power.com)

### KJB48xxEB-20A Dimensions and Recommended Layout

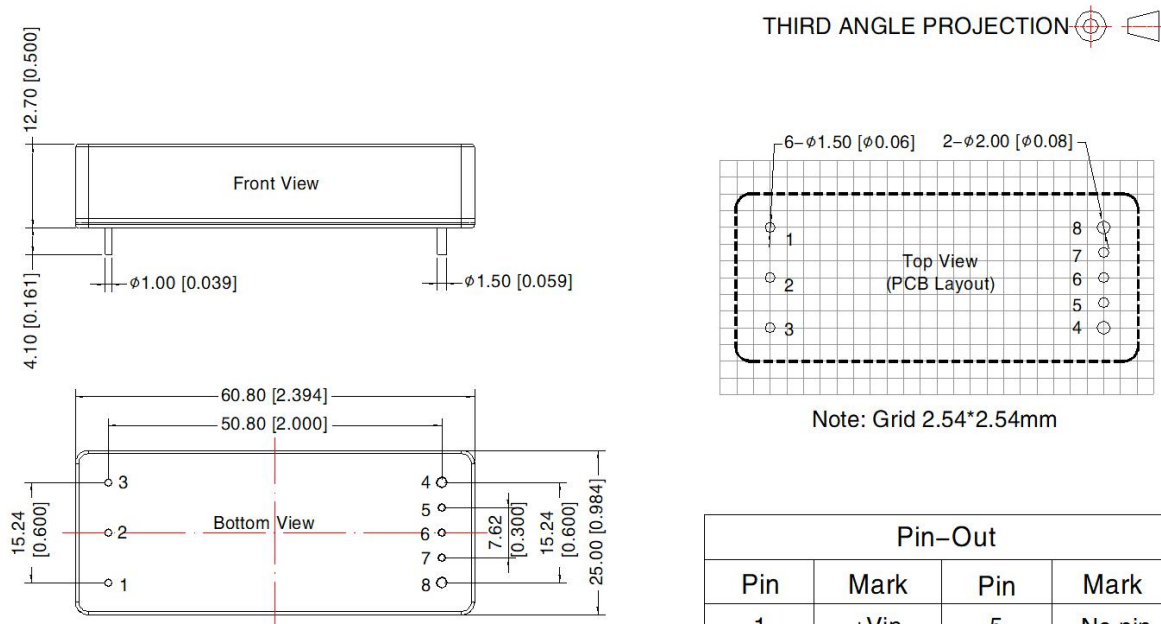

Note:  
Unit: mm[inch]  
Pin1,2,3,6,7 diameter: 1.00[0.039]  
Pin4,8 diameter: 1.50[0.059]  
Pin diameter tolerances:  $\pm 0.10[\pm 0.004]$   
General tolerances:  $\pm 0.50[\pm 0.020]$

Pin-Out			
Pin	Mark	Pin	Mark
1	+Vin	5	No pin
2	Ctrl	6	Trim
3	-Vin	7	Sense+
4	0V	8	+Vo

KJB48xxEBF-20A Dimensions and Recommended Layout

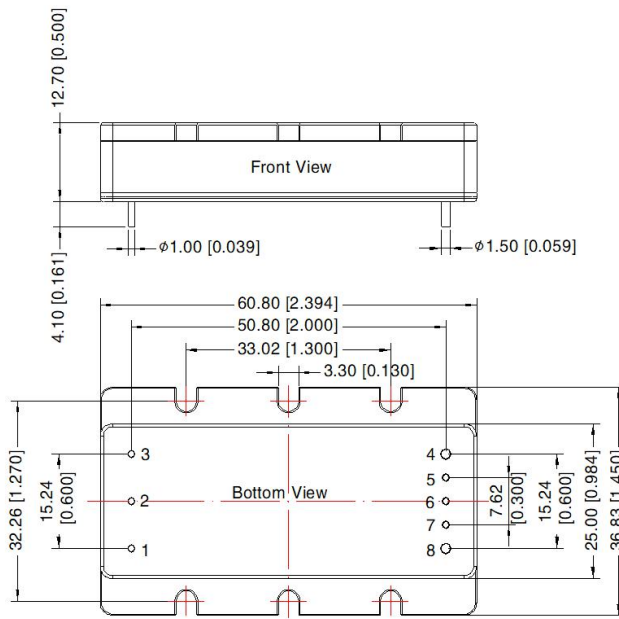

Note:  
Unit: mm[inch]  
Pin 1,2,3,6,7 diameter: 1.00[0.039]  
Pin 4,8 diameter: 1.50[0.059]  
Pin diameter tolerances:  $\pm 0.10[\pm 0.004]$   
General tolerances:  $\pm 0.50[\pm 0.020]$

THIRD ANGLE PROJECTION

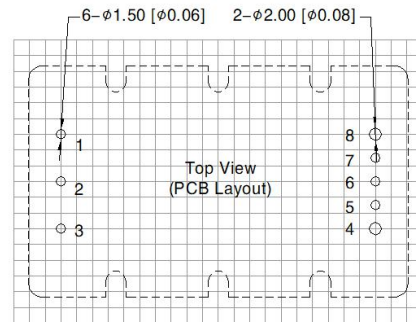

Note: Grid 2.54\*2.54mm

Pin-Out			
Pin	Mark	Pin	Mark
1	+Vin	5	No pin
2	Ctrl	6	Trim
3	-Vin	7	Sense+
4	0V	8	+Vo

Notes:

- For additional information on Product Packaging please refer to [www.mornsun-power.com](http://www.mornsun-power.com). Packaging bag number: 58010113;
- If the product is not operated within the required load range, the product performance cannot be guaranteed to comply with all parameters in the datasheet;
- The maximum capacitive load offered were tested at input voltage range and full load;
- Unless otherwise specified, parameters in this datasheet were measured under the conditions of  $T_a=25^\circ\text{C}$ , humidity<75%RH with nominal input voltage and rated output load;
- All index testing methods in this datasheet are based on our company corporate standards;
- We can provide product customization service, please contact our technicians directly for specific information;
- Products are related to laws and regulations: see "Features" and "EMC";
- Our products shall be classified according to ISO14001 and related environmental laws and regulations, and shall be handled by qualified units.

MORNSUN Guangzhou Science & Technology Co., Ltd.

Address: No. 5, Kehui St. 1, Kehui Development Center, Science Ave., Guangzhou Science City, Huangpu District, Guangzhou, P. R. China

Tel: 86-20-38601850

Fax: 86-20-38601272

E-mail: [info@mornsun.cn](mailto:info@mornsun.cn)

[www.mornsun-power.com](http://www.mornsun-power.com)