

### Common Mode Filter



### ● FEATURES

- Small size
- Good temperature characteristic
- Effective anti-interference
- High reliability
- Various inductance values

The filter is suitable for applications that are sensitive to noise, such as analog circuits, and the EMC level can be significantly improved by adding FL2D-xx-xxx to the input end of the power module.

### Selection Guide

Model	*Inductance (uH)	Current (A)(max)	DCR(mΩ) (max)	Weight (g) (typ)	Size(mm) (L x W x H)	Product Chart
FL2D-50-102	1000*2	5.0	30*2	13	23.00 x 13.20 x 23.00 See Figure1	Reference Diagram①
FL2D-50-332	3300*2	5.0	38*2	13	23.00 x 13.20 x 23.00 See Figure1	Reference Diagram①
FL2D-50-562	5600*2	5.0	47*2	13	23.00 x 13.20 x 23.00 See Figure1	Reference Diagram①
FL2D-50-103	10000*2	5.0	56*2	18	27.00 x 13.20 x 27.00 See Figure2	Reference Diagram①
FL2D-50-203	20000*2	5.0	45*2	24	31.50 x 18.00 x 30.00 See Figure3	Reference Diagram②
FL2D-60-451	450*2	6.0	9*2	6.4	18.00 x 15.00 x 17.00 See Figure4	Reference Diagram③
FL2D-60-402	4000*2	6.0	35*2	20	24.00 x 23.50 x 19.00 See Figure5	Reference Diagram④
FL2D-60-702	7000*2	6.0	75*2	21	23.00 x 14.50 x 31.50 See Figure6	Reference Diagram⑤
FL2D-70-360C	36*2	7.0	2.5*2	21.3	31.20 x 31.20 x 17.50 See Figure7	Reference Diagram⑥
FL2D-70-402	4000*2	7.0	20*2	40	31.00 x 31.00 x 23.00 See Figure8	Reference Diagram⑦
FL2DN-80-151	150*2	8.0	50*2	18	27.00 x 27.00 x 13.00 See Figure9	Reference Diagram⑧
FL2D-80-102	1000*2	8.0	30*2	15	23.00 x 13.20 x 23.00 See Figure10	Reference Diagram⑨
FL2D-80-162	1600*2	8.0	40*2	36	37.00 x 37.00 x 18.00 See Figure12	Reference Diagram⑩
FL2D-80-332	3300*2	8.0	30*2	15	23.00 x 13.20 x 23.00 See Figure10	Reference Diagram⑨
FL2D-80-562	5600*2	8.0	38*2	20	27.00 x 13.20 x 27.00 See Figure12	Reference Diagram⑨
FL2D-90-102	1000*2	9.0	10*2	34	32.50 x 31.00 x 20.00 See Figure13	Reference Diagram⑪
FL2D-90-203	20000*2	9.0	30*2	36	32.00 x 18.00 x 31.00 See Figure14	Reference Diagram⑫

Note:\*1.The inductance values are tested under the conditions of T=25°C,The inductance values of FL2D-50-203,FL2D-70-402,FL2D-60-702,FL2D-90-102/203 are the minimum values, while the inductance values of other models are typical values.

### General Specifications

Item	Test Conditions	Applicable Model	Min.	Typ.	Max.	Unit
Operating Temperature *		FL2D-50-102	-40	--	+125	
		FL2D-80-102				
		FL2D-70-360C	-50	--	+125	
		Others	-40	--	+115	
		FL2D-60-402	-40	--	+105	
		FL2D-60-451				
		FL2D-80-162				
FL2DN-80-151						
FL2D-90-203						
Storage Temperature		FL2D-70-360C	-50	--	+125	°C
		Others	-40	--	+115	
		FL2D-60-402	-40	--	+105	
		FL2D-60-451				
		FL2D-60-702				
		FL2D-70-402				
		FL2D-80-162				
FL2DN-80-151						
FL2D-90-102/203						
Welding Temperature	Wave soldering, maximum 10 seconds		+255	+260	+265	
	Manual soldering, with the solder joint 1.5mm away from the shell, for 10 seconds.		--	--	+300	
Storage Humidity	Non-condensing		5	--	95	%RH
Inductance Error Range	fo=1kHz, Uo=0.3V	FL2D-60-402 FL2D-60-451	-35	--	--	%
	fo=1KHz, Uo=0.3V	Others	--	30	--	%
	fo=10KHz, Uo=0.1V,T=25°C	FL2D-80-162 FL2DN-80-151	--	35	--	
		FL2D-70-360C	-35	--	+35	%
	fo=1KHz, Uo=0.25V	FL2D-60-702	The inductance values are all defined as the minimum values			
fo=10KHz, Uo=0.1V,T=25°C	FL2D-50-203 FL2D-70-402 FL2D-90-102/203					
Isolation Voltage(COIL-COIL)	Electric strength test for 1 minute with a leakage current of 1mA max	FL2D-60-402 FL2D-60-451	--	--	2000	VDC
		FL2D-70-360C	--	--	1500	VDC
	Electric strength test for 1 minute with a leakage current of 5mA max	FL2D-50-203 FL2D-70-402 FL2D-90-102 FL2D-60-702	--	--	1000	VAC
		FL2D-80-162 FL2DN-80-151 FL2D-90-203	--	--	1500	
		Others	--	--	1500	

# EMC Filter Inductor

FL2D-xx-xxx(5A-9A)

		--	--	2000	VDC
Vibration	FL2D-60-402、 FL2D-60-451 FL2D-70-360C	IEC60077, IEC 61373 - Category 1, Grade B			
	FL2D-50-203 FL2D-70-402 FL2D-90-102/203 FL2D-80-162 FL2DN-80-151 FL2D-60-702	10~55Hz, 10g, X,Y,Z direction ,2mm			
Warranty	Ambient temperature: <40°C	3 years			

Note: \*1.Operating Temperature range includes inductor self heating.

\*\*2.The soldering temperature resistance of the pins is not the actual set temperature of the soldering iron, but the temperature required for a good solder joint. The actual set temperature by the customer needs to be comprehensively set based on the thickness of the PCB, the size of the copper cladding, the power of the soldering iron, and the selection of the soldering iron tip.

## Schematic Diagram

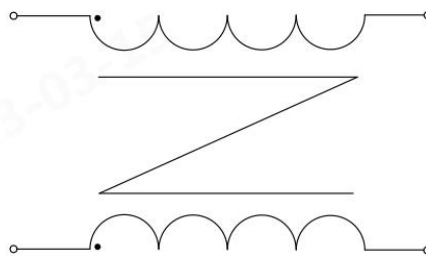

## FL2D-50-XXX Common Mode Insertion Loss Curve (Reference Value)

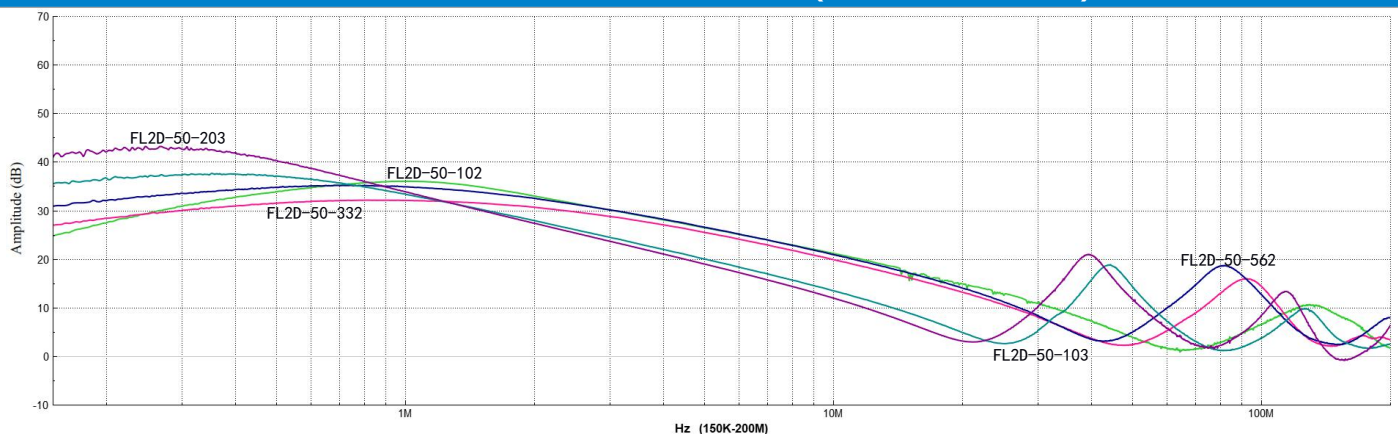

### FL2D-50-XXX Differential Mode Insertion Loss Curve (Reference Value)

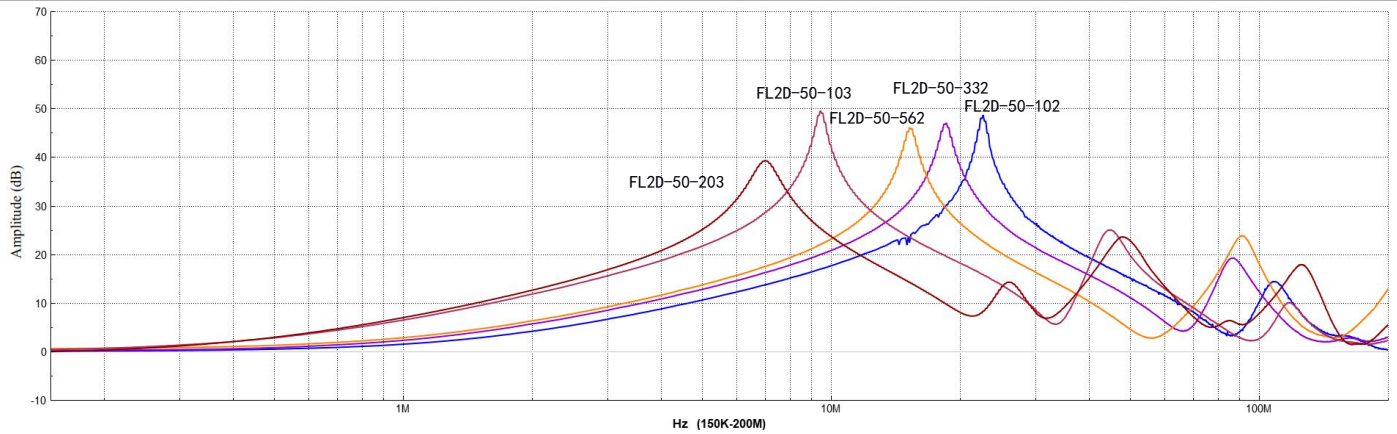

### FL2D-60-XXX Common Mode Insertion Loss Curve (Reference Value)

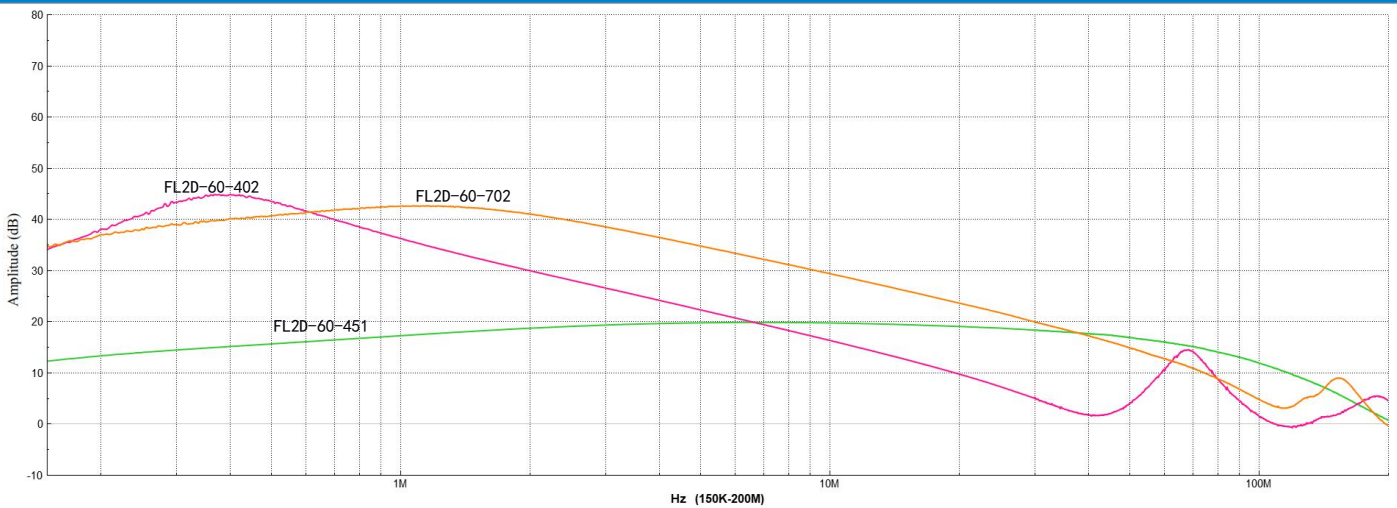

### FL2D-60-XXX Differential Mode Insertion Loss Curve (Reference Value)

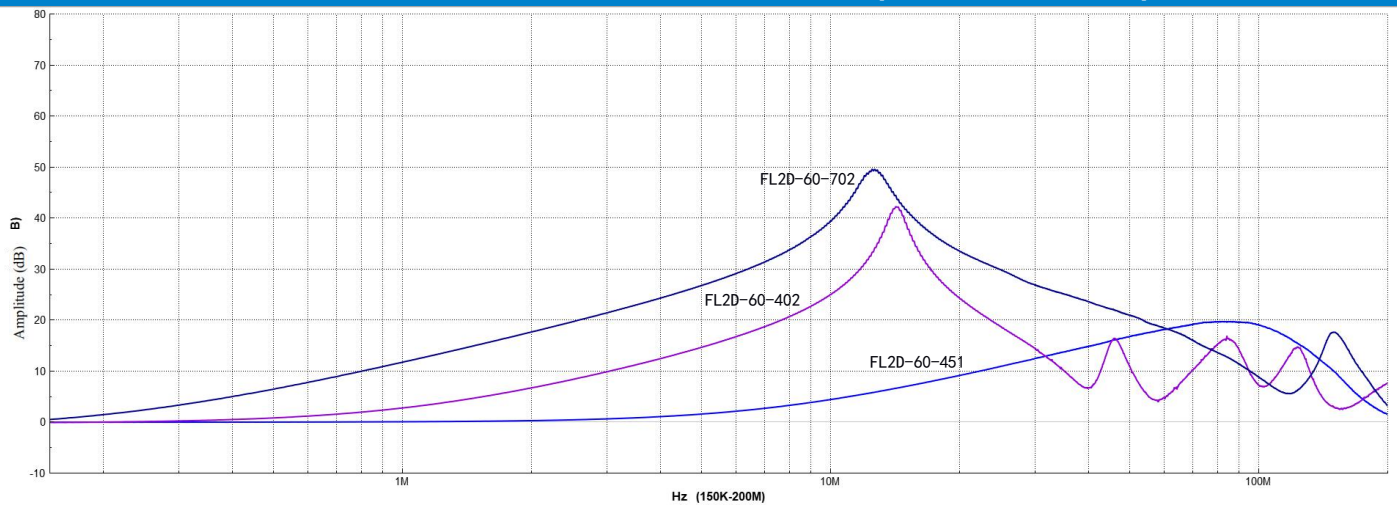

### FL2D-70-XXX Common Mode Insertion Loss Curve (Reference Value)

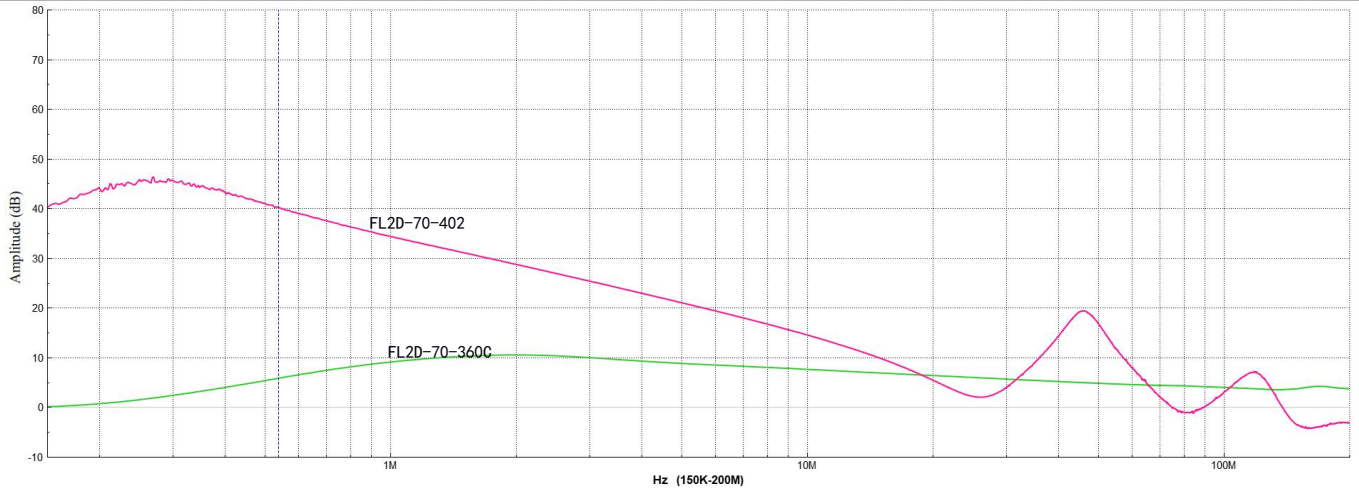

### FL2D-70-XXX Differential Mode Insertion Loss Curve (Reference Value)

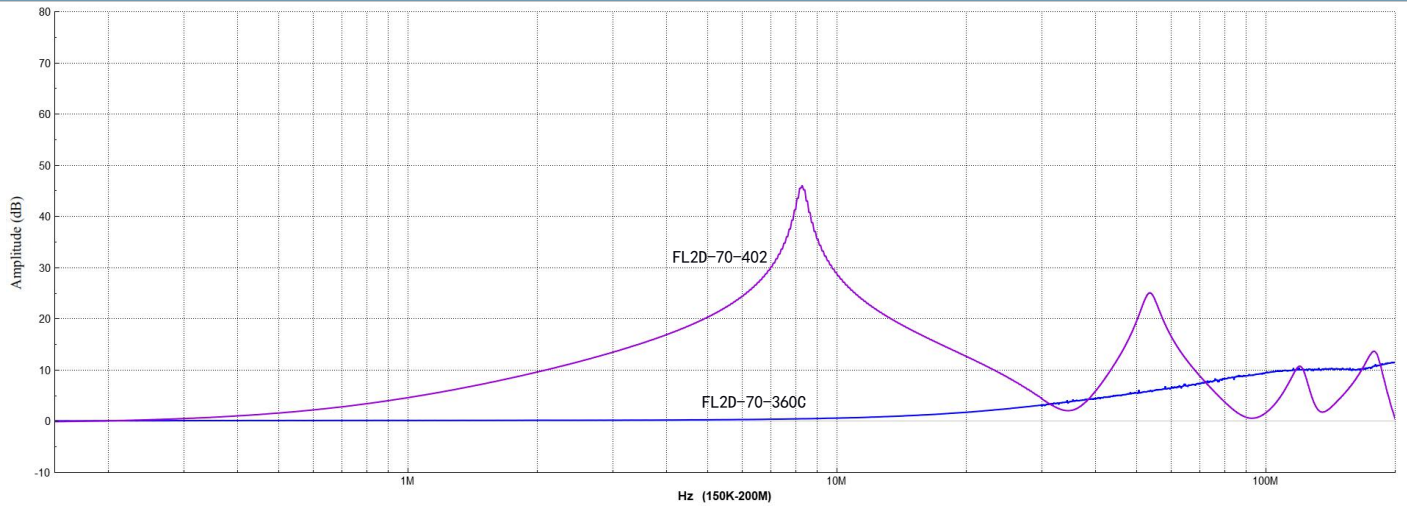

### FL2D-80-XXX Common Mode Insertion Loss Curve (Reference Value)

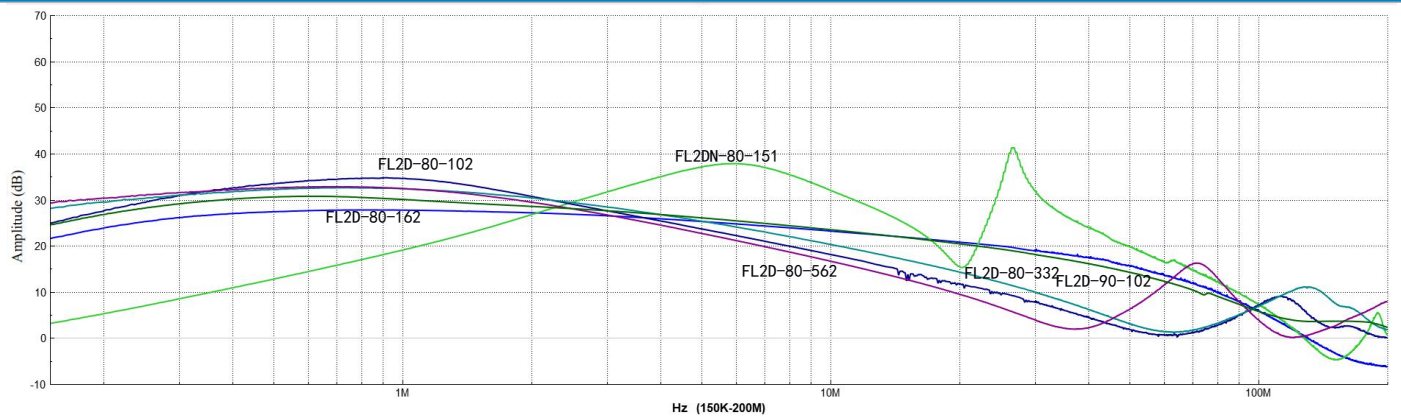

### FL2D-80-XXX Differential Mode Insertion Loss Curve (Reference Value)

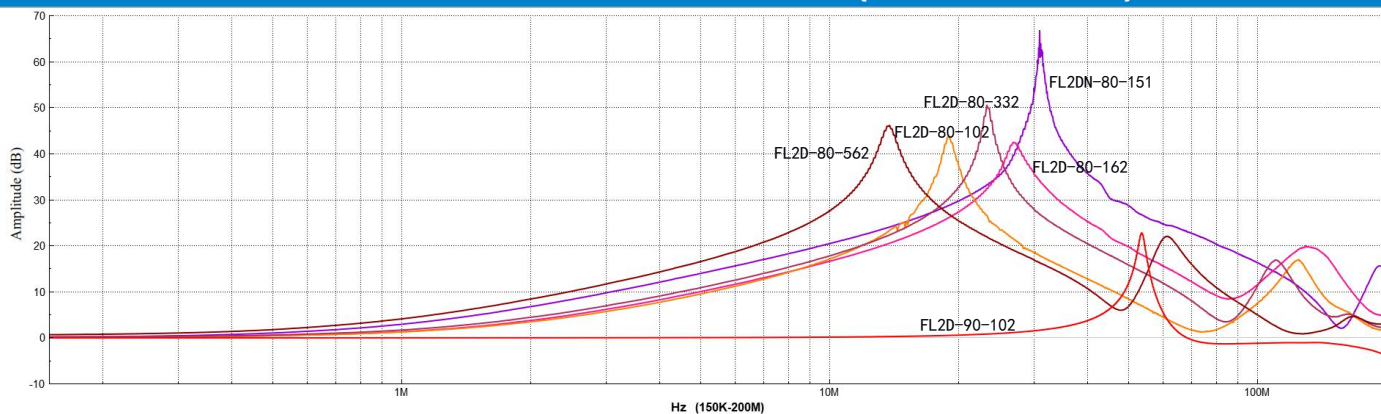

### FL2D-90-XXX Common Mode Insertion Loss Curve (Reference Value)

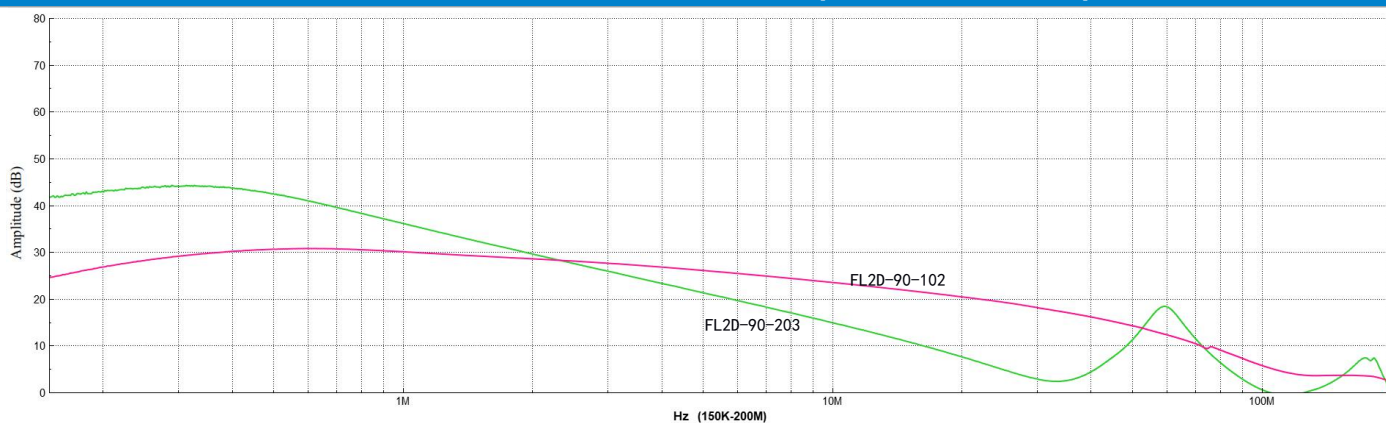

### FL2D-90-XXX Differential Mode Insertion Loss Curve (Reference Value)

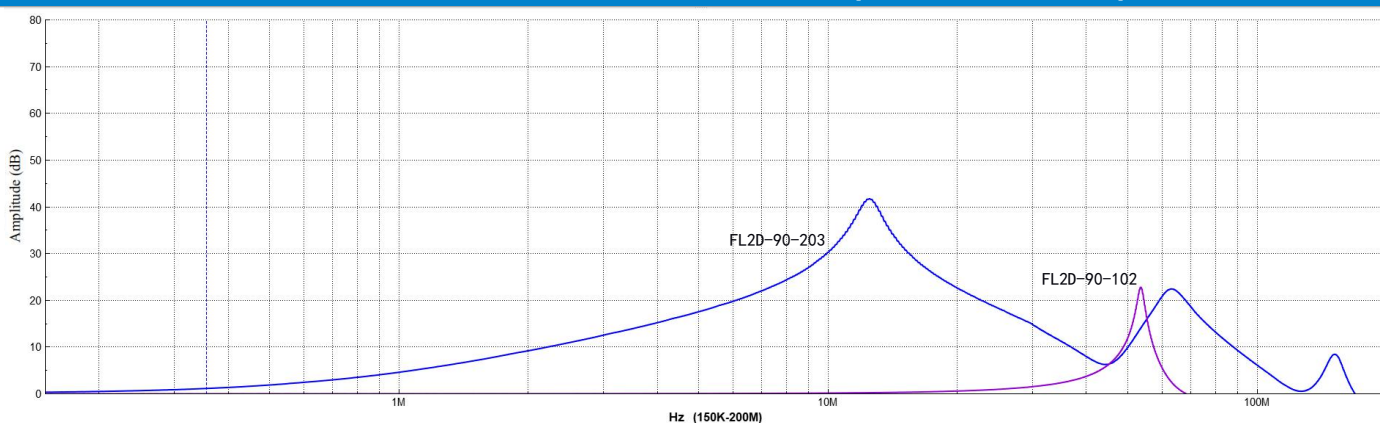

### Temperature Derating Curve (Reference Value)

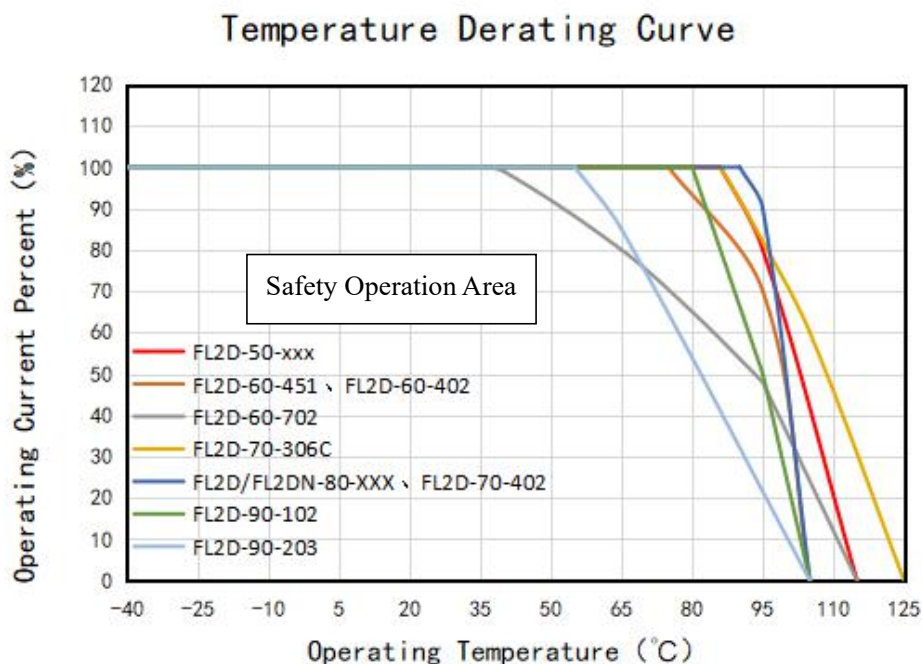

Note: This product is suitable for use in safe working areas, such as in non-safe working areas, it is recommended to use forced air cooling and other heat dissipation measures.

### FL2D-50-102/332/562 Schematic Diagram Of Pin Mark

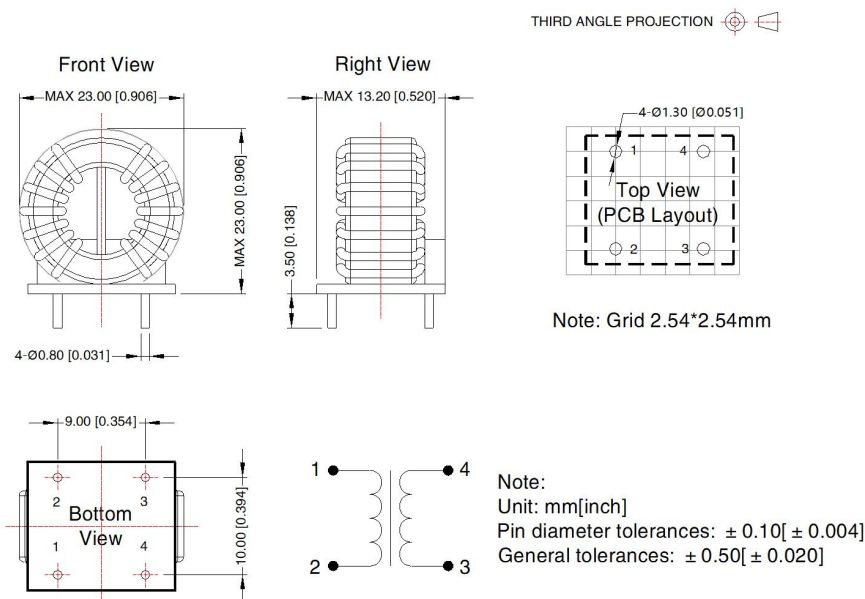

Fig.1

### FL2D-50-103 Schematic Diagram Of Pin Mark

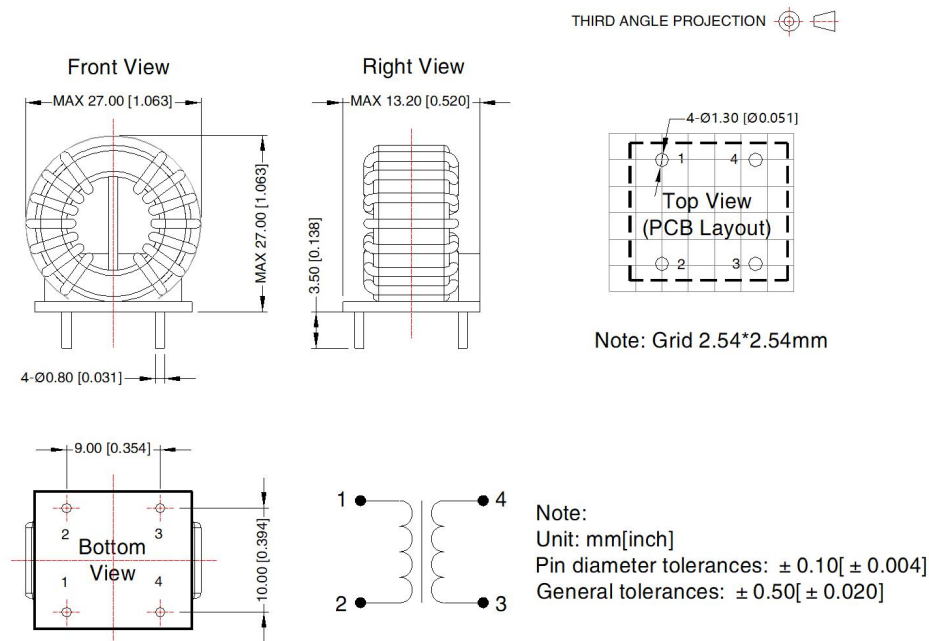

Fig.2

### FL2D-50-203 Schematic Diagram Of Pin Mark

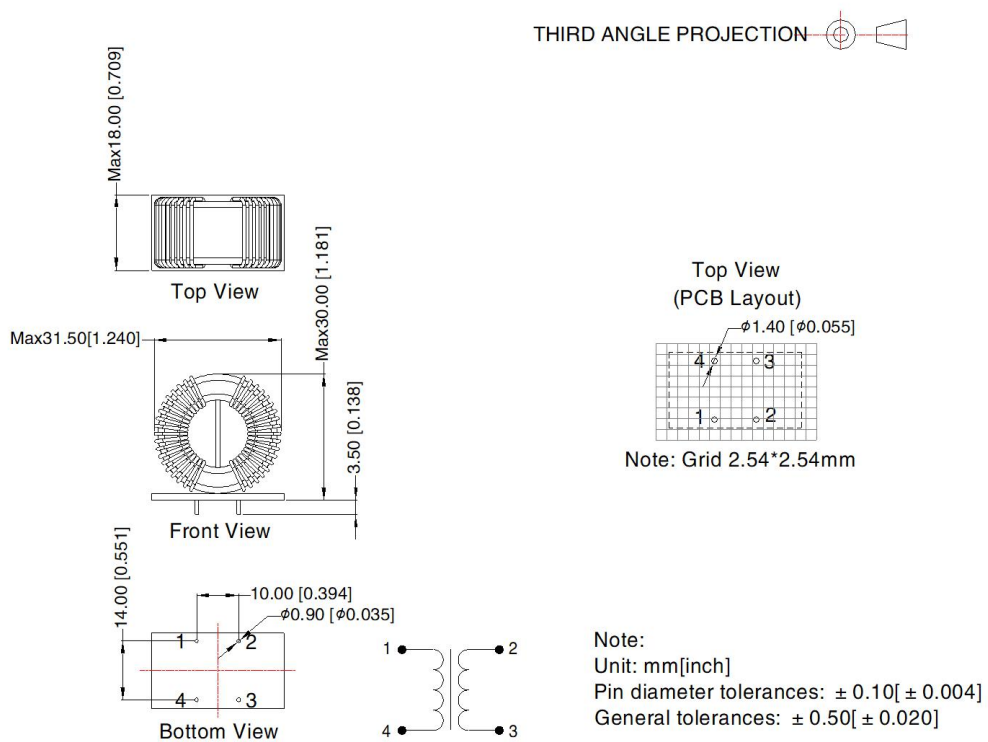

Fig.3

### FL2D-60-451 Schematic Diagram Of Pin Mark

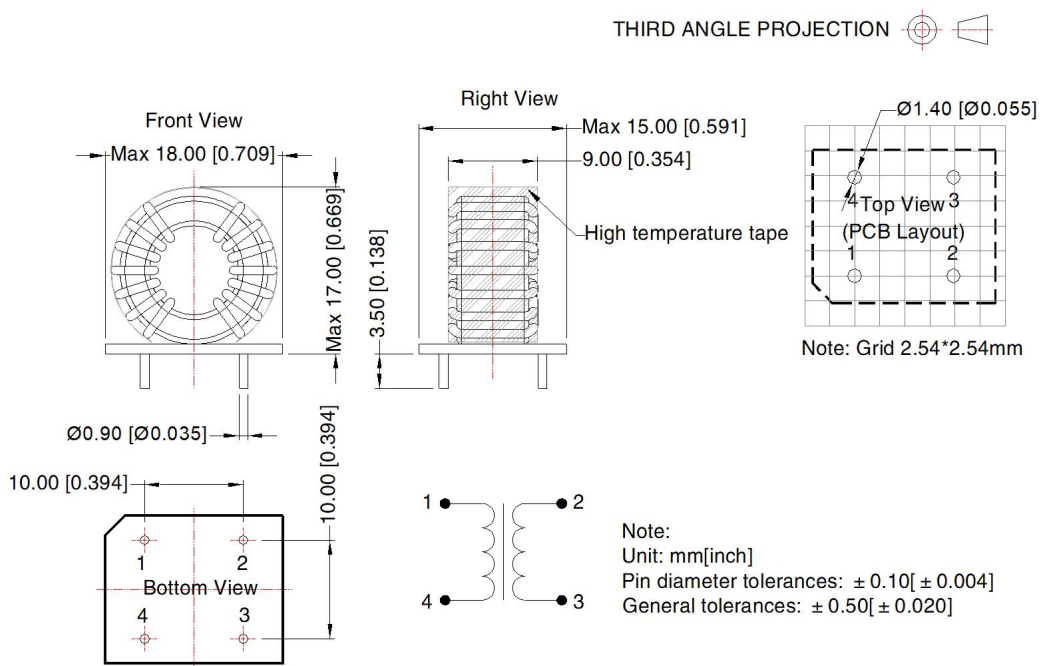

Fig.4

### FL2D-60-402 Schematic Diagram Of Pin Mark

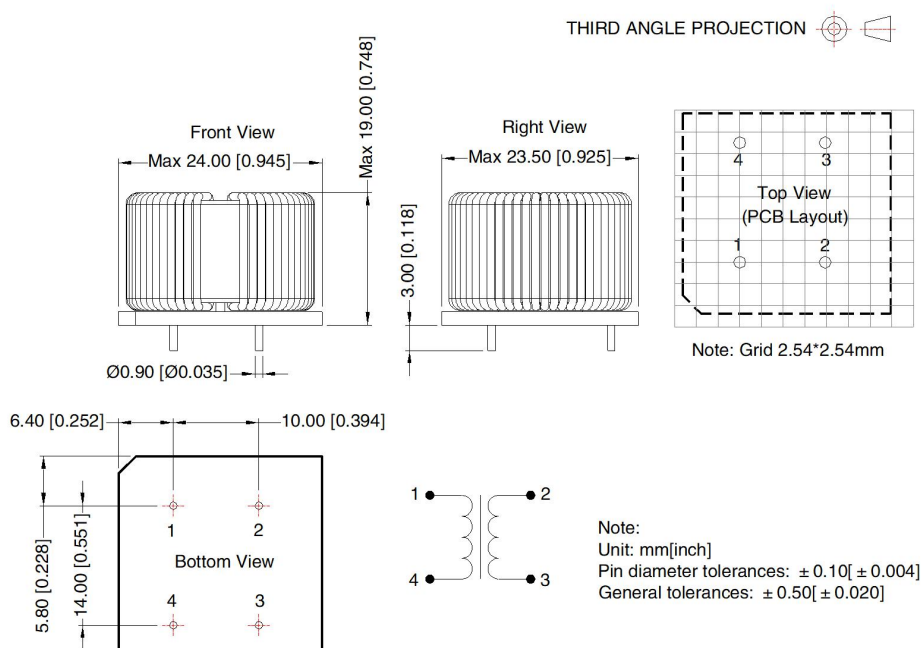

Fig.5

FL2D-60-702 Schematic Diagram Of Pin Mark

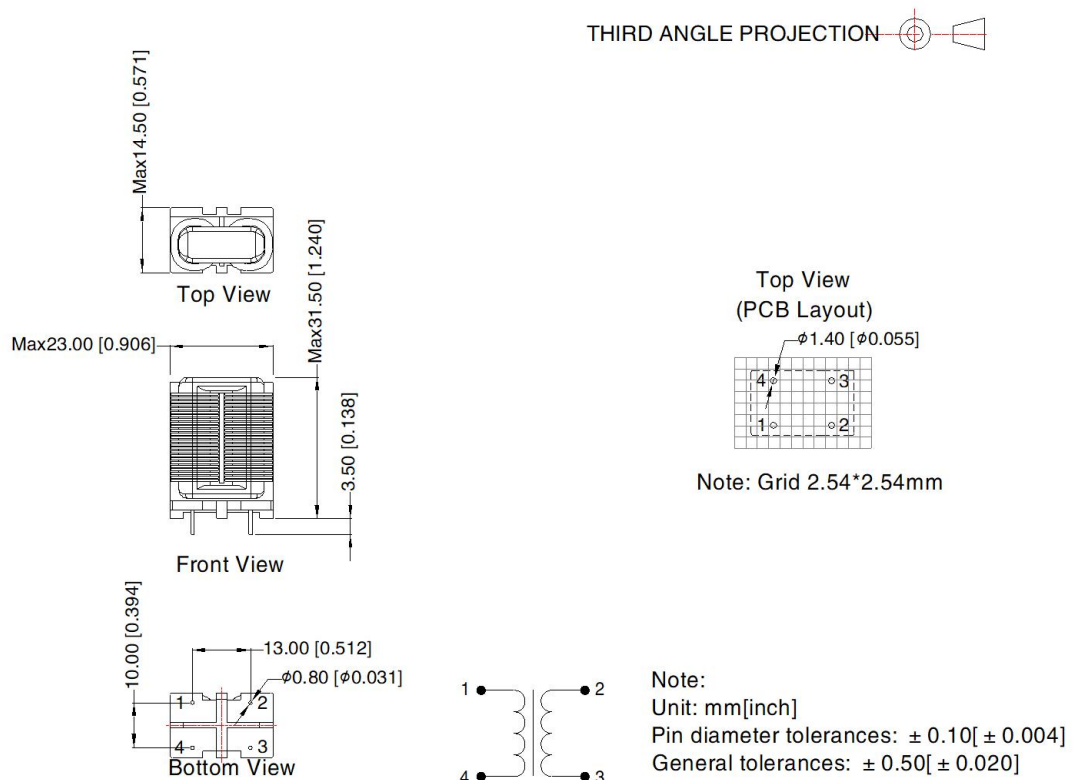

Fig.6

FL2D-70-360C Schematic Diagram Of Pin Mark

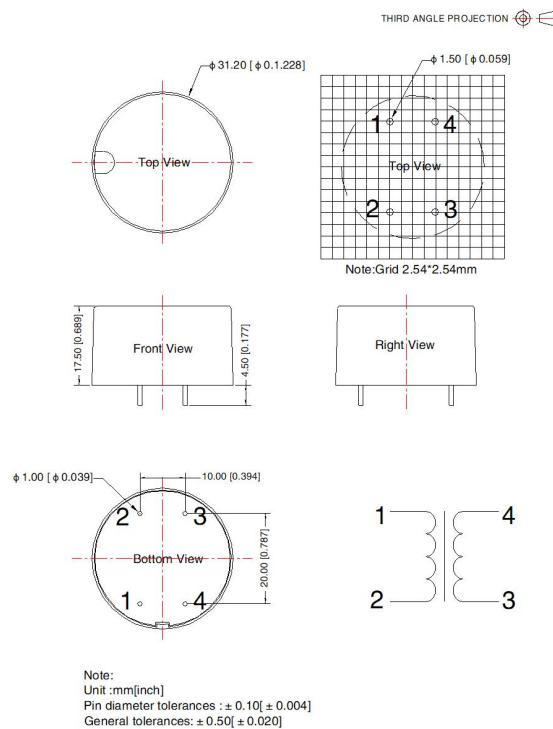

Fig.7

### FL2D-70-402 Schematic Diagram Of Pin Mark

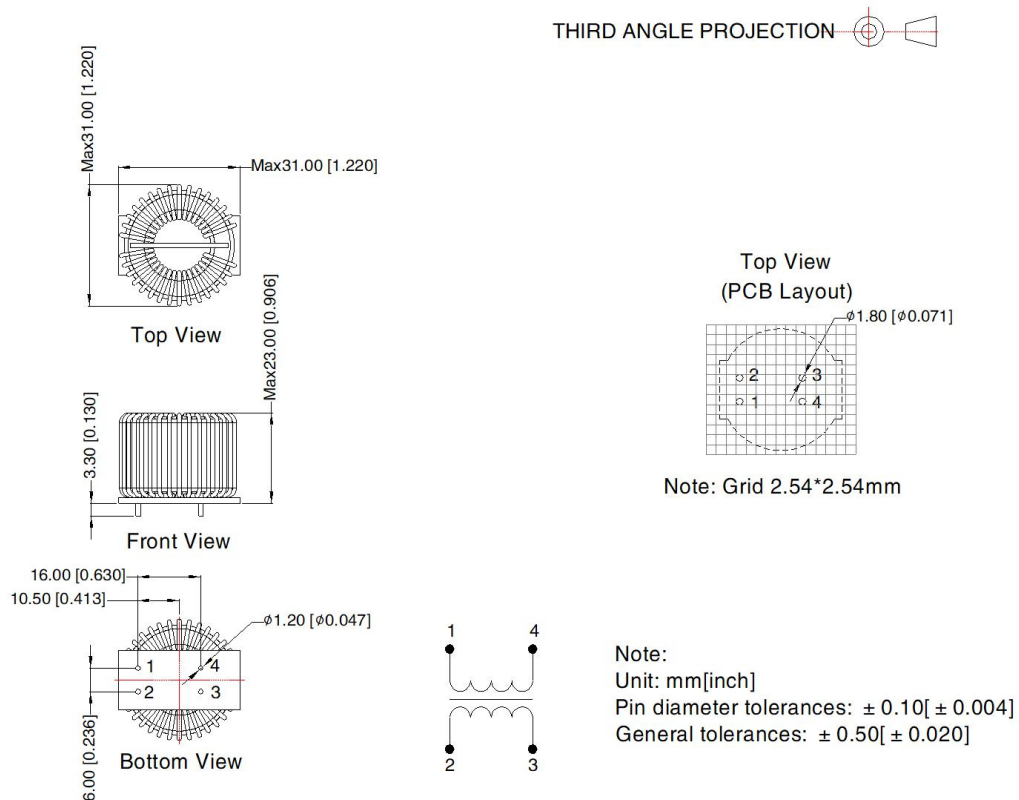

Fig.8

### FL2DN-80-151 Schematic Diagram Of Pin Mark

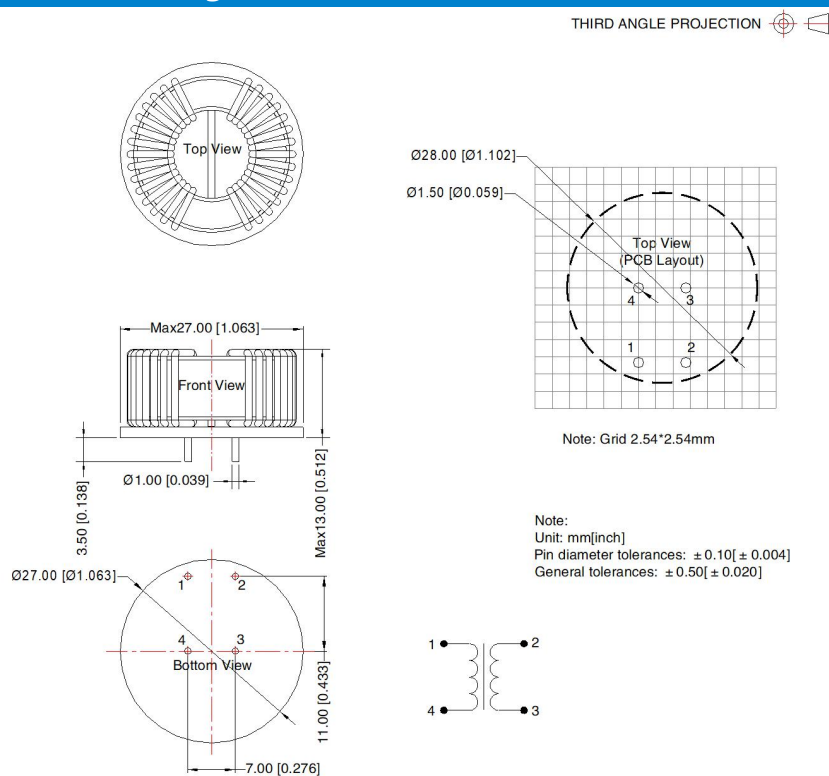

Fig.9

### FL2D-80-102/332 Schematic Diagram Of Pin Mark

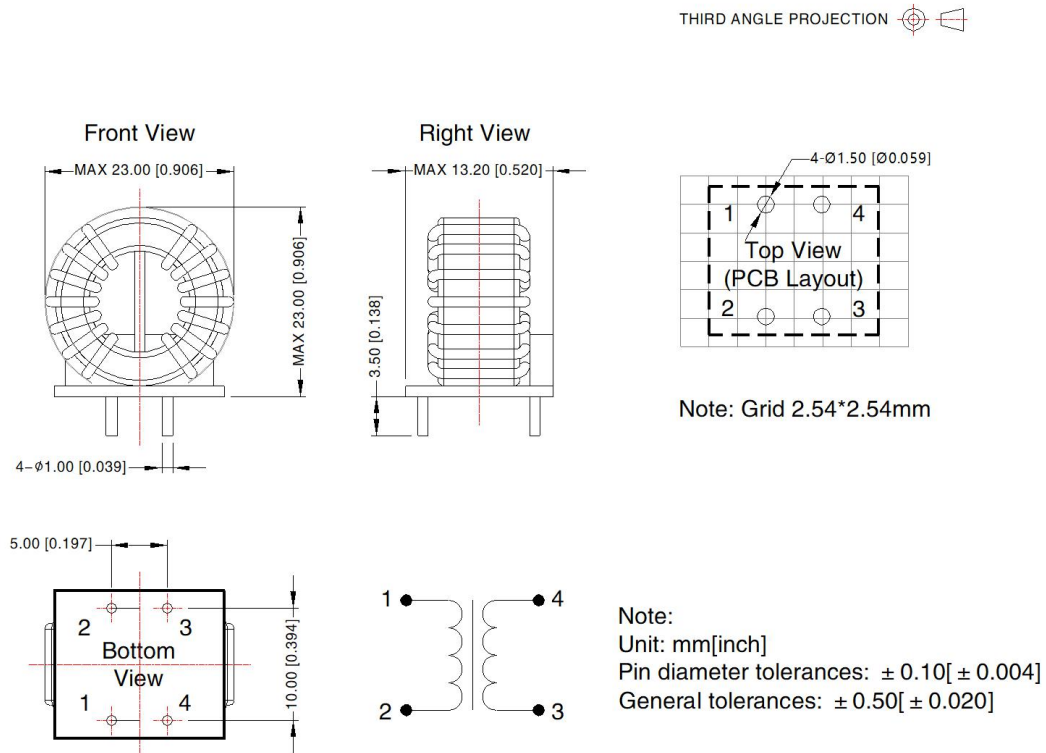

Fig.10

### FL2D-80-162 Schematic Diagram Of Pin Mark

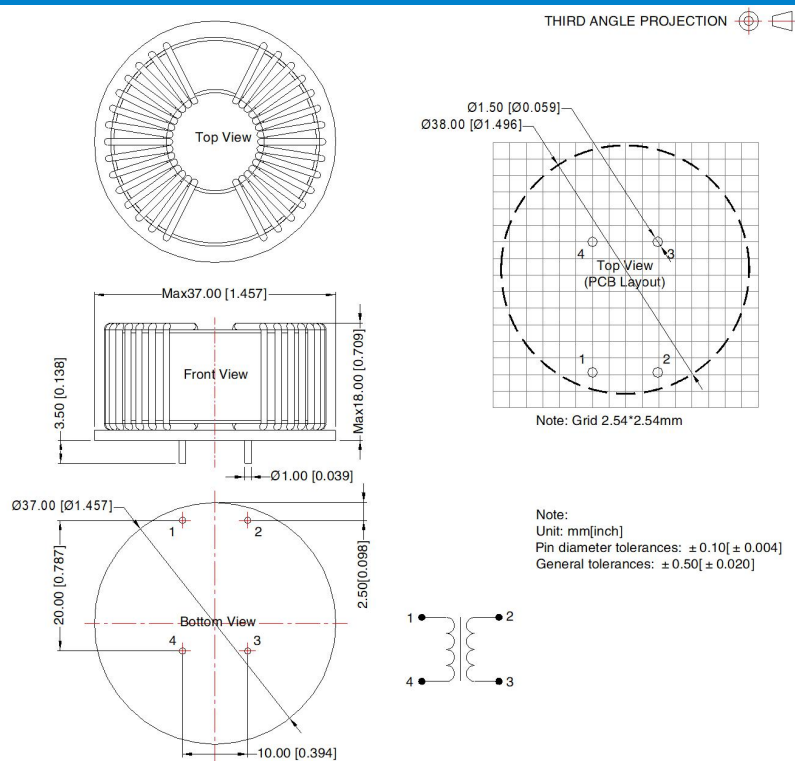

Fig.11

### FL2D-80-562 Schematic Diagram Of Pin Mark

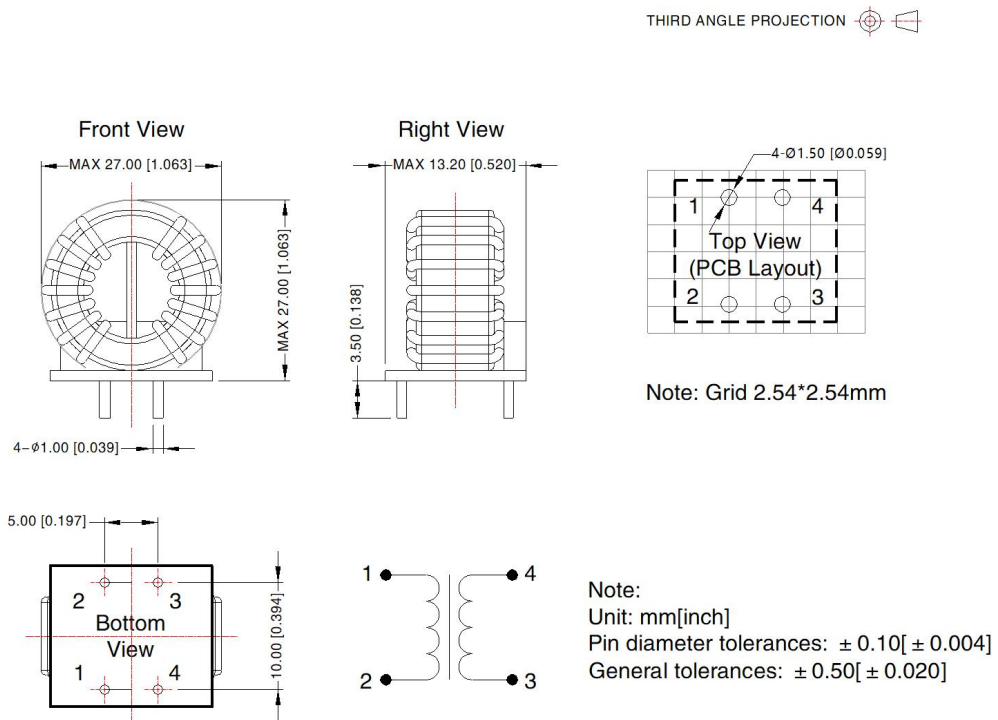

Fig.12

### FL2D-90-102 Schematic Diagram Of Pin Mark

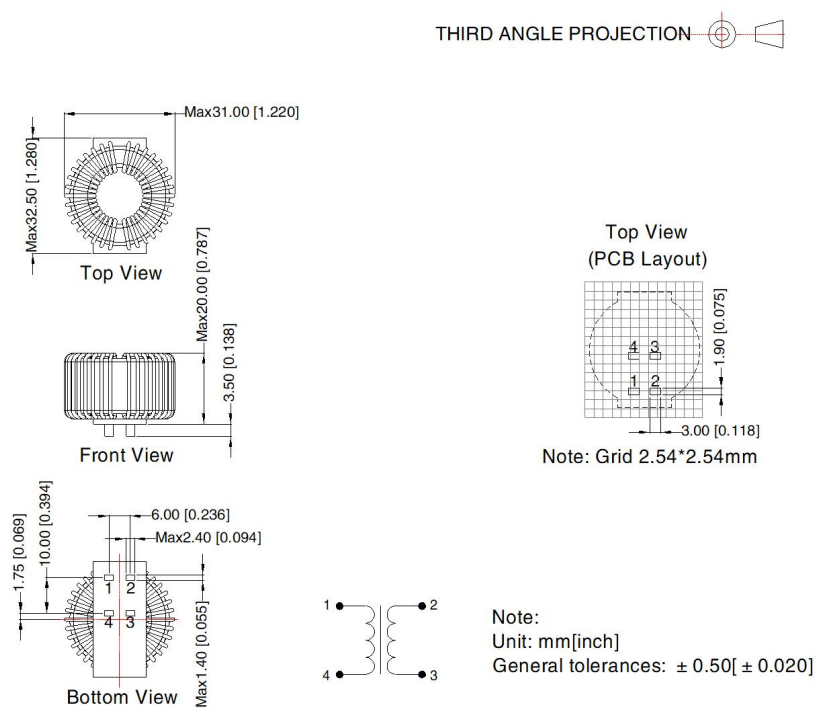



Fig.13

### FL2D-90-203 Schematic Diagram Of Pin Mark

第三角投影 

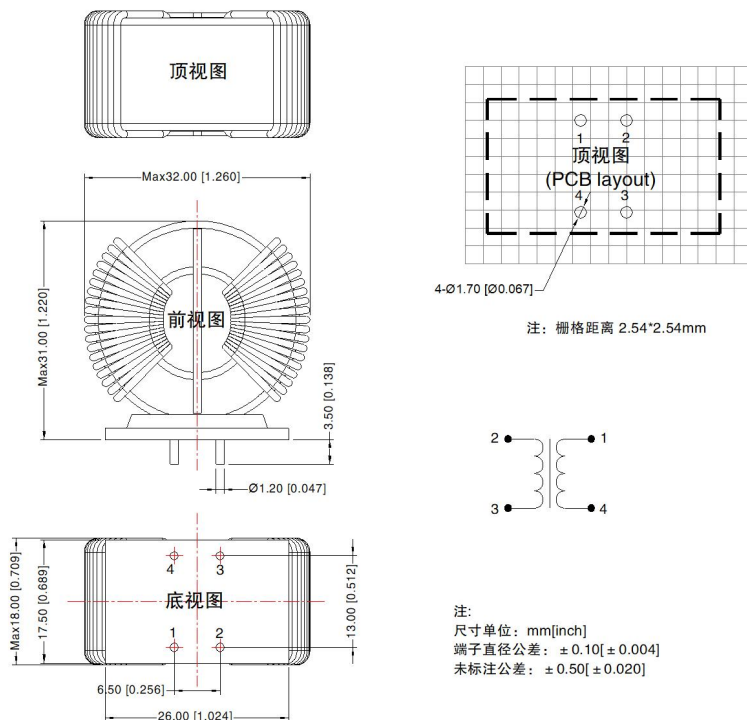

Fig.14

**Note:**

1. For additional information on Product Packaging please refer to [www.mornsun-power.com](http://www.mornsun-power.com). Packaging bag number: 58200055(FL2D-50-102、FL2D-50-332、FL2D-50-562、FL2D-50-103、FL2D-80-102、FL2D-80-332、FL2D-80-562)、58210394(FL2D-50-203、FL2D-90-203)、58210146(FL2D-60-402)、58210147(FL2D-60-451)、58210396(FL2D-60-702)、58200055(FL2D-70-360C)、58240096(FL2D-70-402)、58210365(FL2DN-80-151)、58240094(FL2D-80-162)、58240096(FL2D-90-102)
2. Unless otherwise specified, data in this data sheet should be tested under the conditions of Ta=25°C, humidity<75%RH;
3. All index testing methods in this datasheet are based on company corporate standards;
4. The performance indexes of the product models listed in this manual are as above, but some indexes of non-standard model products will exceed the above-mentioned requirements, and please directly contact our technicians for specific information;
5. We can provide product customization service, please contact our technicians directly for specific information;
6. Products are related to laws and regulations: see "Features" ;
7. Our products shall be classified according to ISO14001 and related environmental laws and regulations, and shall be handled by qualified units.

## Mornsun Guangzhou Science & Technology Co., Ltd.

Address: No. 8 Nanyun 4th Road, Huangpu District, Guangzhou, China

Tel: 86-20-38601850

Fax: 86-20-38601272

E-mail: [info@mornsun.cn](mailto:info@mornsun.cn)

[www.mornsun-power.com](http://www.mornsun-power.com)