

URB_LD-15W Series

15W, WIDE INPUT, ISOLATED & REGULATED SINGLE OUTPUT DC-DC CONVERTER

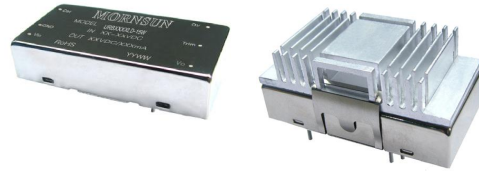

RoHS

FEATURES

- Efficiency up to 85%
- 4:1 wide input voltage range
- 1.5kVDC input/output isolation
- Short circuit protection (automatic recovery)
- Operating temperature: -40°C ~ +85°C
- Internal SMD construction
- Metal shielding package
- Industry standard pinout
- MTBF>1,000,000 hours
- RoHS Compliance

PRODUCT PROGRAM

Part Number	Input			Output		Efficiency (% Typ.)	Capacitor Load ⁽³⁾ (max,µF)
	Voltage (VDC)			Voltage (VDC)	Current ⁽²⁾ (mA)		
	Nominal	Range	Max. ⁽¹⁾				
URB2403LD-15W	24	9-36	40	3.3	4000	80	10200
URB2405LD-15W				5	3000	82	4020
URB2412LD-15W				12	1250	85	1035
URB2415LD-15W				15	1000	85	705
URB4803LD-15W	48	18-75	80	3.3	4000	81	10200
URB4805LD-15W				5	3000	83	4020
URB4812LD-15W				12	1250	85	1035
URB4815LD-15W				15	1000	85	705

Note: Add suffix "H" for heatsink mounted, for example URB2405LD-15WH.

APPLICATION

The URB_LD-15W series offer 15W of output, with 4:1 wide input voltage range of 9-36VDC, 18-75VDC and features 1500VDC isolation, over current, over voltage and short-circuit protection, as well as six sided shielding. All models are particularly suited to industrial, tele-communications, test equipments power.

INPUT SPECIFICATIONS

Item	Test conditions	Min.	Typ.	Max.	Units
Start-up voltage	24 Vin models	--	--	9	VDC
	48 Vin models	--	--	18	
Input filter		LC			
Start-up time		--	10	--	ms
Ctrl ⁽⁴⁾	Models ON	3.5 - 40VDC or open circuit			
	Models OFF	0 - 1.2VDC			

MODEL SELECTION

URB2405LD-15W

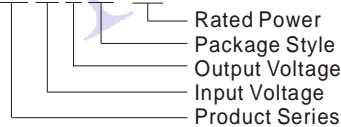

OUTPUT SPECIFICATIONS

Item	Test conditions	Min.	Typ.	Max.	Units
Output power	See product program	1.5	--	15	W
Output voltage accuracy	Refer to recommended circuit	--	±1	±3	%
Load regulation	From 10% to 100% load	--	±0.5	±1	
Line regulation	Input voltage from low to high	--	±0.2	±0.5	
Ripple and noise	20MHz Bandwidth	55	75	150	mV
Transient recovery time	25%~50%~25% load or	--	200	500	us
Transient peak deviation	50%~75%~50% load step change	--	±2	±5	%
Over current protection	Input voltage range	120	130	150	%
Over voltage protection	3.3V output models	--	3.9	--	VDC
	5V output models	--	6.2	--	
	12V output models	--	15	--	
	15V output models	--	18	--	
Output Short Circuit	Input voltage range	Hiccup, automatics recovery			
Trim		--	±10%Vo	--	VDC
Temperature drift (Vout)	Refer to recommended circuit	--	±0.02	--	%/°C

MORNSUN Science & Technology Co.,Ltd.

Address: No. 5, Kehui St. 1, Kehui development center, Science Ave., Guangzhou Science City, Luogang district, Guangzhou,P.R.China.

Tel: 86-20-28203030

Fax:86-20-28203068

[Http://www.mornsun-power.com](http://www.mornsun-power.com)

COMMON SPECIFICATIONS

Item	Test conditions	Min.	Typ.	Max.	Units
Operating temperature		-40	--	85	°C
Storage temperature		-55	--	125	
Storage humidity		5	--	95	
Cooling		Free Air Convection			
Maximum Case temp.	On working temperature	--	--	105	°C
Lead temperature	1.5mm from case for 10 seconds	--	--	300	
Isolation voltage	Tested for 1 minute and 1mA max	1500	--	--	VDC
Isolation resistance	Test at 500VDC	1000	--	--	MΩ
Isolation capacitance	100kHz /0.1V	--	1000	--	pF
Switching frequency	Nominal, full load	--	300	--	kHz
MTBF	M1L-HDBK-217F	1000	--	--	k hours
Case material		Nickel- coated copper (Six-sided)			
Weight		--	40	--	g

TRIM APPLICATION & TRIM RESISTANCE

Application circuit for TRIM (Part in broken line is the interior of models)

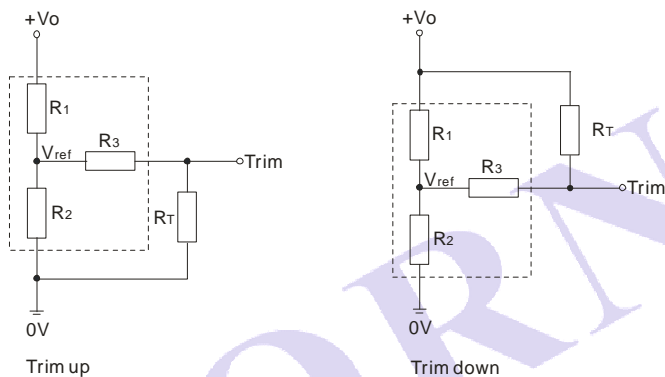

Formula for resistance of Trim

$$\text{up: } R_T = \frac{aR_2}{R_2 - a} - R_3 \quad a = \frac{V_{ref}}{V_o' - V_{ref}} \cdot R_1$$

$$\text{down: } R_T = \frac{aR_1}{R_1 - a} - R_3 \quad a = \frac{V_o' - V_{ref}}{V_{ref}} \cdot R_2$$

Note: Value for R1, R2, R3, and Vref refer to the following table.

R_T: Resistance of Trim

a: User-defined parameter, no actual meanings.

V_o: The trim up/down voltage

Vo	3.3(VDC)	5(VDC)	12(VDC)	15(VDC)
Resistance				
R1(KΩ)	4.801	2.883	10.971	14.497
R2(KΩ)	2.863	2.864	2.864	2.864
R3(KΩ)	15	10	17.8	17.8
Vref(V)	1.24	2.5	2.5	2.5

RECOMMENDED CIRCUIT

1) Recommended circuit



(Fig.1)

In order to obtain better performance for the DC/DC models. It's recommended that use input and output filters as Fig.1 shown.

2) Recommended capacitance

Capacitance	Cout	Cin(24V,48V input)
Output voltage		
3.3V,5V	470μF	100μF
12V,15V	220μF	

3) No parallel connection or plug and play

DERATING & EFFICIENCY CURVE

1) Temperature derating curve

(Output Voltage ≤ 5V)

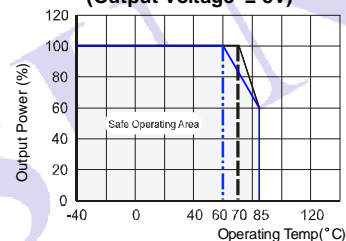

(Output Voltage > 5V)

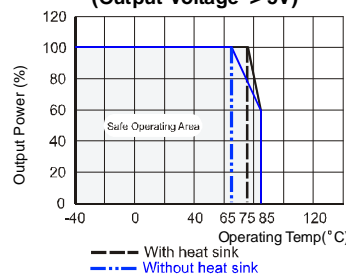

2) Efficiency VS nput voltage (Rated load)

URB2405LD-15W

Efficiency VS Input Voltage

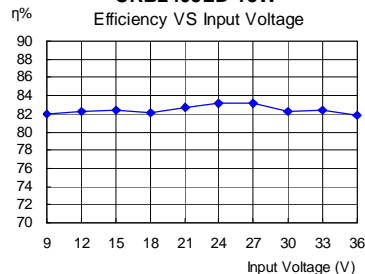

3) Efficiency VS output Load (Nominal input)

URB2405LD-15W

Efficiency VS Output load

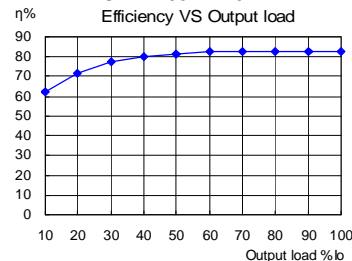

OUTLINE DIMENSIONS & FOOTPRINT DETAILS

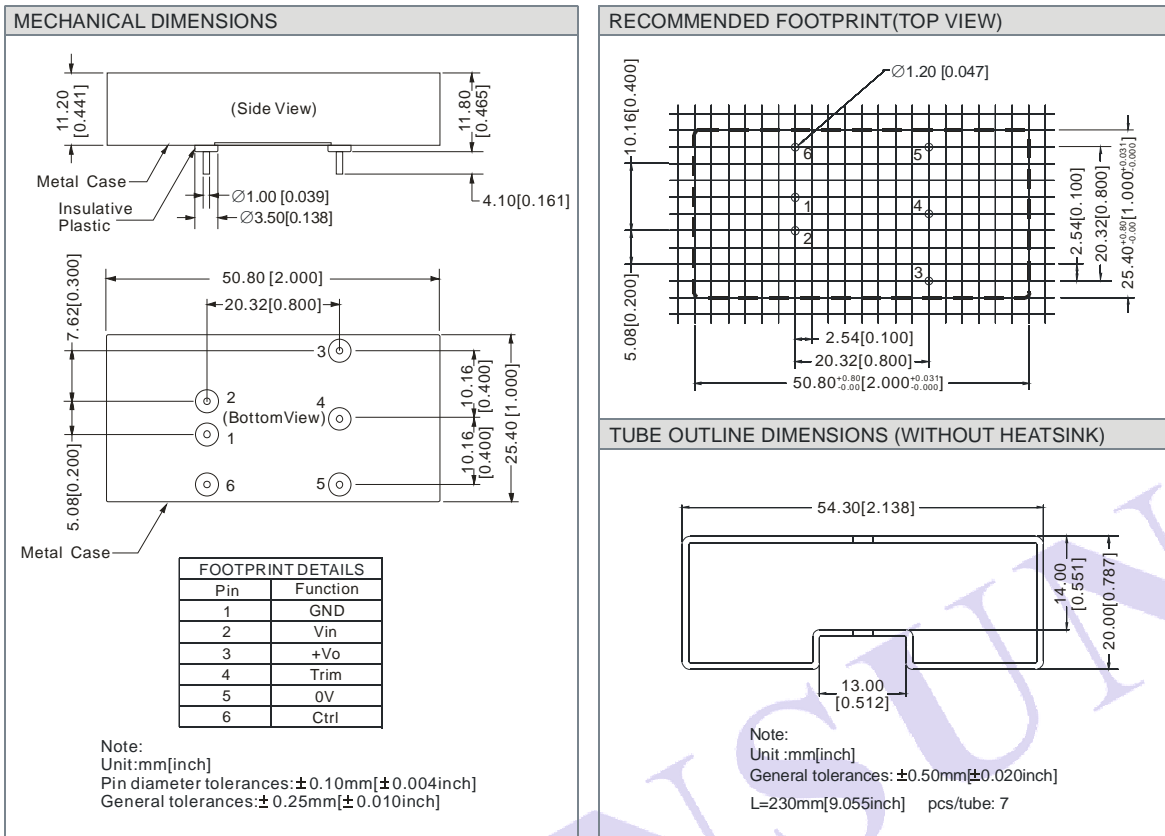

HEATSINK ASSEMBLY

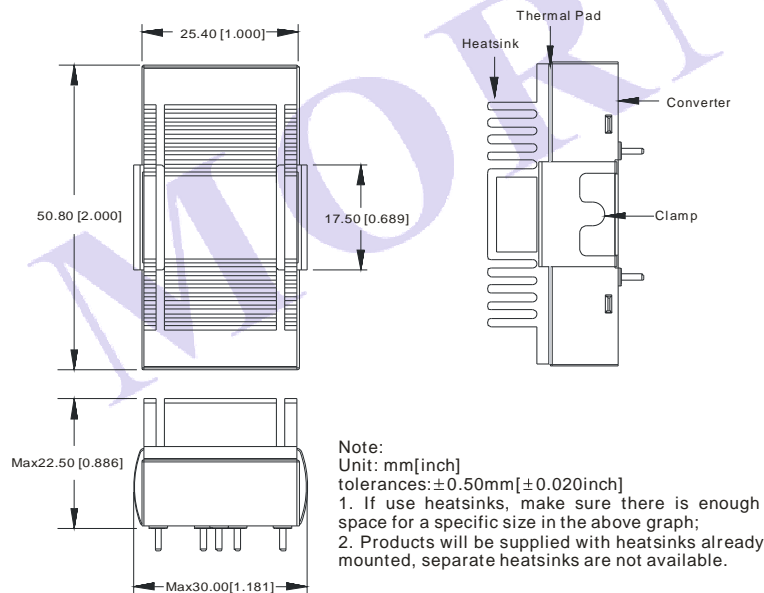

PACKAGE DIAGRAM(WITH HEATSINK)



Package box:
L*W*H=255*170*80mm
Package quantity: 24pcs

NOTE

1. Input voltage can't exceed this value, or will cause the permanent damage.
2. Minimum operating current is 10% of rated current, if less than 10% rated current, output ripple may increase rapidly, the amplitude $\leq 1V$.
3. Capacitor MAX load tested at nominal input voltage, full load and constant resistive load.
4. The CTRL control pin voltage is referenced to GND.
5. Only typical model listed. Non-standard models will be different from the above, please contact us for more details.
6. All specifications are measured at $TA=25^{\circ}C$, humidity<75%, nominal input voltage and rated output load unless otherwise specified.
7. In this datasheet, all the test methods of indications are based on corporate standards.