

QC962 Hybrid Integrated IGBT Driver

QC962 is a hybrid integrated IGBT driver designed for driving N-channel IGBT modules in any gate amplifier application. The device provides the required electrical isolation between input and output with the opto-coupler. Short circuit protection is provided by a built-in desaturation detector. A fault signal is provided if the short circuit protection is activate.

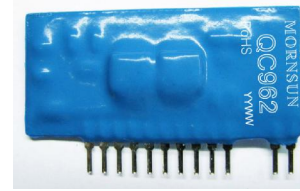

RoHS

FEATURES

- Built in high CMRR opto-coupler (CMR:Typical: 30kV/μs, Min.:15kV/μs)
- Two supply drive topology
- TTL compatible input interface
- Electrical isolation voltage between input and output with opto-couplers (V_{iso}=3750VRMS/min)
- Built in short circuit protection circuit with a pin for fault output
- Controlled time detected short circuit
- Switching frequency up to 20kHz
- Pin and characteristic are compatible with M57962AL

ABSOLUTE MAXIMUM RATINGS

Item	Test Conditions	Limit	Units	
Supply Voltage*	V _{CC}	DC	18	V
	V _{EE}		-15	V
Input Current	I _{in}	Between pin13 and pin14	25	mA
Output Voltage	V _O	Output voltage "H"	V _{CC}	V
Output Current	I _{g on}	Pulse width 2μs	+5	A
	I _{g off}	Frequency f=20kHz	-5	A
Isolation Voltage	V _{iso}	Sine wave voltage 50Hz / 60Hz,1 min.	3750	V
Junction Temperature	T _J		150	°C
Operation Temperature	T _{op}		-20~+70	°C
Storage Temperature	T _{st}		-40~+125	°C
Fault Output Current	I _{FO}	Pin8 input current	20	mA
Input Voltage	V _{R1}	Pin 1 voltage	50	V

Notes: 1. Ta=25°C unless otherwise specified.
2. *20V<V_{CC}-V_{EE}<28V.

APPLICATION

- General-purpose Inverter
- AC Servo Systems
- Uninterruptable Power Supplies(UPS)
- Welding Machines

RECOMMENDED MODULES

- 600V Series IGBT(up to 600A)
- 1200V Series IGBT(up to 400A)
- 1700V Series IGBT(up to 200A)

MORNSUN Science & Technology Co.,Ltd.

Address: No. 5, Kehui St. 1, Kehui development center, Science Ave., Guangzhou Science City, Luogang district, Guangzhou,P.R.China.

Tel: 86-20-28203030

Fax:86-20-28203068

[Http://www.mornsun-power.com](http://www.mornsun-power.com)

ELECTRICAL CHARACTERISTIC

Characteristics	Test Conditions	Value			Units	
		Min	Typ.	Max		
Supply Voltage	V _{CC}	Recommended Range	14	15		V
	V _{EE}		-7		-10	V
Switching frequency	f	Recommended Range	0		20	kHz
Gate resistant	R _G	Recommended Range	2			Ω
"H" input current	I _{IH}	Recommended Range	10	16	20	mA
"H" output voltage	V _{OH}		13	14		V
"L" output voltage	V _{OL}		-6		-9	V
"L-H" propagation	t _{PLH}	I _{IH} =16mA		0.5	1	μs
"L-H" rise time	t _r	I _{IH} =16mA		0.6	1	μs
"H-L" propagation	t _{PHL}	I _{IH} =16mA		1	1.3	μs
"H-L" fall time	t _f	I _{IH} =16mA		0.4	1	μs
Protection reset time	t _{timer}		1	1.3	2	ms
Fault output current	I _{FO}	Pin8 input current, R=4.7K		5		mA
Controlled time detect short circuit 1	T _{trip1}	Pin1: ≥15V,Pin2:open		2.6		μs
Controlled time detect short circuit 2	T _{trip2}	Pin1:≥15V Pin2- Pin4:1000pF		3		μs
Soft turn-off time	T _{off2}	PIN1:≥15V		5		μs
SC detect voltage	V _{SC}	Collector voltage of module	15			V

Notes: 1. Ta=25°C, V_{CC}=15V, V_{EE}=-10V. unless otherwise specified
2. "H" represents high level; "L" represents low level.

APPLICATION EXAMPLES

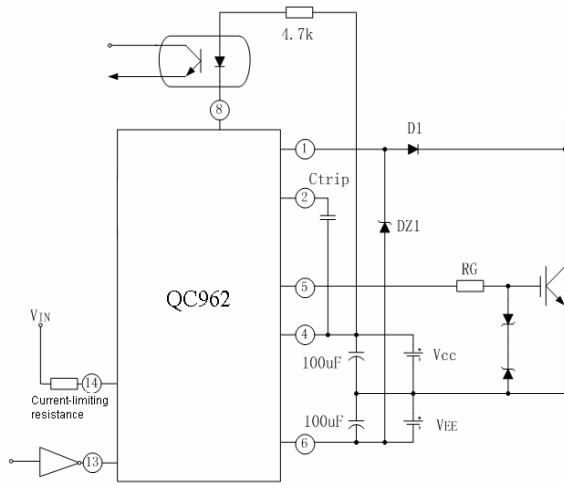

TTL compatible input interface
 Duty:50%
 $V_{IN}=5V$
 $R_G=3.1\Omega$
 D_1 :Fast Recovery Diode($t_{rr}\leq 0.2\mu s$)

$f=20kHz$
 $V_{CC}=15V$
 $V_{EE}=10V$
 $C_{trip}=0\sim 3300pF$

APPLICATION NOTES

1. The IGBT gate-emitter drive loop wiring must be shorter than one meter.
2. The IGBT gate-emitter drive loop wiring should be twisted.
3. If large voltage spike is generated at the collector of the IGBT, increase the IGBT gate resistor.
4. Pin3,7,9,10 are used only for the test circuit and not be connected with the application circuit.
5. The external blocking capacitors must be connected as close as possible to the driver's pin.
6. Peak reverse voltage of the diode D1 must be higher than the peak value of the IGBT collector voltage.
7. The distance between the capacitor Ctrip and pin2-4 should be as short as possible(Max.5cm)
8. Pin1 voltage could be high due to the reverse recovery characteristic of the diode D₁ and the 30V zener diode DZ1 is connected between pin1 and pin6 for protecting the driver.
9. The input signal voltage must be less than 5.25V. The higher input signal voltage, the higher input signal current. It will result in more dissipation. The input port is a circuit composed of a high-speed optocoupler series with a 150ohm resistor. Practically, a current-limiting resistor is inserted, which value can be obtained according to the following equation:

$$R = \frac{V_{in} - 1.7V}{16mA} - 150\Omega$$

OUTLINE DRAWING

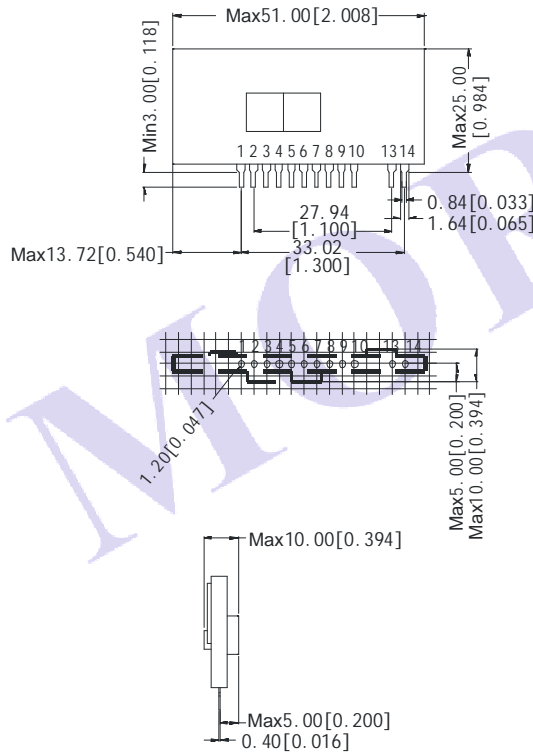

Note:
 Unit: mm[inch]
 Pin section: 0.84*0.40 mm [0.033*0.016inch]
 Pin section tolerances: ± 0.10 mm [± 0.004 inch]
 General tolerances: ± 0.30 mm [± 0.012 inch]

PIN FUNCTION

Pin number	Description
1	Fault detect
2	Reaction time
4	Power supply(+)
5	Drive output
6	Power supply(-)
8	Fault signal output
13	Drive signal input(-)
14	Drive signal input(+)
3, 7, 9, 10	Not connected

PACKAGE DIAGRAM

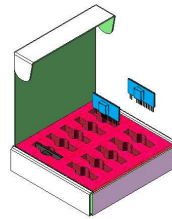

(small white box)

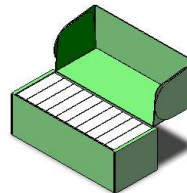

(inner packaging box)

Small white box dimensions: L*W*H=163*150*35mm

Packaging quantity: 10PCS

Inner packaging box dimensions: L*W*H=430*175*160mm

Packaging quantity: 100PCS

Outer packaging carton dimensions: L*W*H=560*450*520mm

Packaging quantity: 900PCS