

## QC841 Hybrid Integrated IGBT Driver

QC841 is a hybrid integrated IGBT driver built-in electrical isolation between power devices and control circuits with the high CMRR opto-coupler. Short circuit protection is provided by a built-in desaturation detector. A fault signal is provided if the short circuit protection is activate.

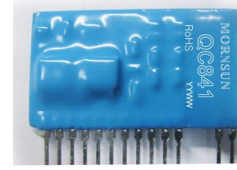

RoHS

### FEATURES

- Built in high CMRR opto-coupler (CMR:Typical:30kV/μs, Min.:15kV/μs)
- Electrical isolation voltage between input and output with opto-couplers (Viso=3750VRMS/min)
- Switching frequency up to 20kHz
- Single supply drive topology
- Built in short circuit protection circuit with a pin for fault output
- Soft IGBT turn-off and protection circuit time reset
- Pins are compatible with EXB841

### ABSOLUTE MAXIMUM RATINGS

Item	Test Conditions	Limit	Units
Supply Voltage*	V <sub>CC</sub> DC	25	V
Input current	I <sub>in</sub> Between Pin14 and Pin15	25	mA
Output current	I <sub>g on</sub> Pulse width 2μs	+5	A
	I <sub>g off</sub> Frequency f=20kHz	-5	A
Isolation Voltage	Viso Sinewave voltage 50Hz/60Hz 1 min.	3750	V
Operation Temperature	T <sub>opr</sub>	-20~+70	°C
Storage Temperature	T <sub>stg</sub>	-40~+125	°C
Fault Output Current	I <sub>FO</sub> Pin5 input current	20	mA
Input Voltage	V <sub>R1</sub> Pin6 input voltage	50	V

Note: Ta=25°C; unless otherwise specified.

### APPLICATION

- I General-purpose Inverter
- I AC Servo Systems
- I Uninterruptable Power Supplies(UPS)
- I Welding Machines

### RECOMMENDED MODULES

- I 600V Series IGBT(up to 600A)
- I 1200V Series IGBT(up to 400A)
- I 1700V Series IGBT(up to 200A)

### MORNSUN Science & Technology Co.,Ltd.

Address: No. 5, Kehui St. 1, Kehui development center, Science Ave., Guangzhou Science City, Luogang district, Guangzhou, P.R.China.

Tel: 86-20-28203030

Fax:86-20-28203068

[Http://www.mornsun-power.com](http://www.mornsun-power.com)

### ELECTRICAL CHARACTERISTIC

Characteristics	Test Conditions	Value			Units
		Min	Typ.	Max	
Supply Voltage	V <sub>CC</sub> Recommended Range	18	20	22	V
Reverse bias power supply voltage	V <sub>RB</sub> Recommended Range		-5		V
Switching frequency	f Recommended Range	0		20	kHz
Gate resistor	R <sub>G</sub> Recommended Range	2			Ω
"H" input current	I <sub>IH</sub> Recommended Range	10	16	20	mA
"H" output voltage	V <sub>OH</sub> V <sub>CC</sub> =20V		14		V
"L" output voltage	V <sub>OL</sub> V <sub>CC</sub> =20V		-5		V
"L-H" propagation	t <sub>PLH</sub> I <sub>IH</sub> =16mA		0.5	1	μs
"L-H" rise time	t <sub>r</sub> I <sub>IH</sub> =16mA		0.6	1	μs
"H-L" propagation	t <sub>PHL</sub> I <sub>IH</sub> =16mA		1	1.3	μs
"H-L" fall time	t <sub>f</sub> I <sub>IH</sub> =16mA		0.4	1	μs
Protection threshold voltage	V <sub>OCP</sub> V <sub>CC</sub> =20V		8.5		V
Protection reset time	t <sub>timer</sub>	1	1.4	2	ms
Fault output current	I <sub>FO</sub> Pin5 input current, R=4.7K			5	mA
Soft turn-off time	T <sub>off2</sub> Pin6: ≥15V		5		μs
Controlled time detect short circuit 1	T <sub>trip1</sub> Pin6: ≥15V, Pin11: open		2.6		μs

Note: 1. Ta=25°C, V<sub>CC</sub>=15V, unless otherwise specified  
2. "H" represents high level; "L" represents low level.

## APPLICATION EXAMPLES

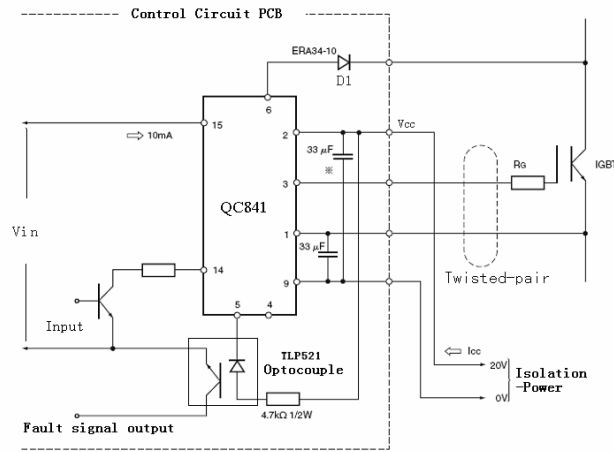

TTL compatible input interface       $f=20\text{kHz}$   
 Duty:50%       $V_{CC}=20\text{V}$   
 $V_{IN}=5\text{V}$        $R_G=3.1\Omega$   
 $D_1$  :Fast Recovery Diode( $t_{rr}\leq 0.2\mu\text{s}$ )

## APPLICATION NOTES

1. The IGBT gate-emitter drive loop wiring must be shorter than one meter.
2. The IGBT gate-emitter drive loop wiring should be twisted.
3. If large voltage spike is generated at the collector of the IGBT, increase the IGBT gate resistor.
4. Pins which not be used must not be connected with the application circuit.
5. The external blocking capacitors must be connected as close as possible to the driver's pin.
6. Peak reverse voltage of the diode D1 must be higher than the peak value of the IGBT collector voltage.
7. The input signal voltage must be less than 5.25V. The higher input signal voltage, the higher input signal current. It will result in more dissipation. The input port is a circuit composed of a high-speed optocoupler series with a 150ohm resistor. Practically, a current-limiting resistor is inserted, which value can be obtained according to the following equation:

$$R = \frac{V_{in} - 1.7V}{16mA} - 150\text{ohm}$$

## OUTLINE DIMENSIONS (UNIT:MM)

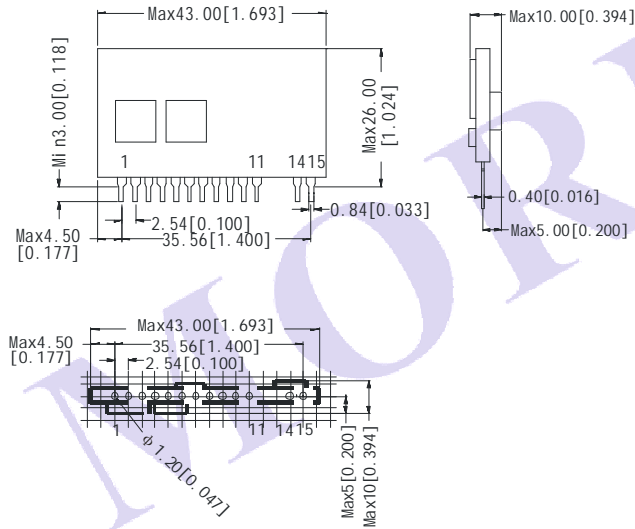

Note:  
 Unit: mm [inch]  
 Pin section: 0.84\*0.40mm [0.033\*0.016 inch]  
 Pin section tolerances:  $\pm 0.10$  mm [ $\pm 0.004$  inch]  
 General tolerances:  $\pm 0.30$  mm [ $\pm 0.012$  inch]

## PIN FUNCTION

Pin number	Description
1	Connected to smoothing capacitor for reverse bias and emitter of IGBT
2	Power supply(+)
3	Drive output
5	Fault signal output
6	Fault detect
9	Gnd
14	Drive signal input(-)
15	Drive signal input(+)
4, 7, 8, 10, 11	Not connected

## PACKAGE DIAGRAM

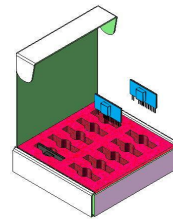

(small white box)

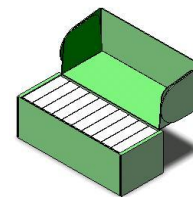

(inner packaging box)

Small white box dimensions: L\*W\*H=163\*150\*35mm  
 Packaging quantity: 10PCS  
 Inner packaging box dimensions: L\*W\*H=430\*175\*160mm  
 Packaging quantity: 100PCS  
 Outer packaging carton dimensions: L\*W\*H=560\*450\*520mm  
 Packaging quantity: 900PCS