

## PWA\_(M)D-3W&PWB\_(M)D-3W Series 3W, WIDE INPUT, ISOLATED & REGULATED DUAL/SINGLE OUTPUT DC-DC CONVERTER

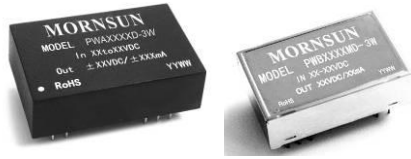

Patent Protection RoHS

### PRODUCT FEATURES

- 4:1 wide input range
- Operating temperature Range: -40°C to +85°C
- 1.5KVDC isolation
- Short circuit protection (automatic recovery)
- Internal SMD construction
- UL94-V0 package
- No external component required
- Industry standard pinout
- Five sides metal shielding (PWA/B\_MD)
- MTBF>1,000,000 hours

### PART NUMBER SYSTEM

PWB2412MD-3W

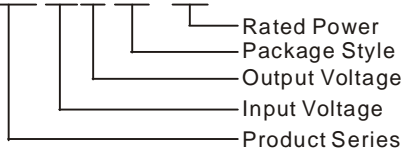

### APPLICATIONS

The PWA\_(M)D-3W & PWB\_(M)D-3W Series are designed for application where isolated output is required from a distributed power system.

These products apply to where:

- 1) Input voltage ranges ≤ 4:1;
- 2) 1.5KVDC input and output isolation;
- 3) Regulated and low ripple noise is required.

### SELECTION GUIDE

Model Number	Input Voltage(VDC)		Output Voltage (VDC)	Output Current (mA)		Input Current (mA)(typ.)		Reflected Ripple Current (mA,typ.)	Max. Capacitive Load(μF)	Efficiency (% , typ.) @Max. Load	
	Nominal (Range)	Max*		Max.	Min.	@Max. Load	@No Load				
PWA2405(M)D-3W	24 (9.0-36)	40	±5	±300	±30	164	20	20	680	76	
PWA2412(M)D-3W			±12	±125	±12	156			330	80	
PWA2415(M)D-3W			±15	±100	±10	156			220	80	
PWB2403(M)D-3W			15	3.3	909	91	169		15	2200	74
PWB2405(M)D-3W				5	600	60	164			1000	76
PWB2409(M)D-3W				9	333	33	160			680	78
PWB2412(M)D-3W				12	250	25	156			470	80
PWB2415(M)D-3W				15	200	20	156			330	80
PWB2424(M)D-3W				24	125	12	160			220	78
PWA4805(M)D-3W				48 (18-72)	80	±5	±300			±30	82
PWA4812(M)D-3W	±12	±125	±12			78	330	80			
PWA4815(M)D-3W	±15	±100	±10			78	220	80			
PWB4803(M)D-3W	10	3.3	909			91	84	10	2200	74	
PWB4805(M)D-3W		5	600			60	80		1000	78	
PWB4809(M)D-3W		9	333			33	80		680	78	
PWB4812(M)D-3W		12	250			25	78		470	80	
PWB4815(M)D-3W		15	200			20	78		330	80	

\*Input voltage can't exceed this value, or will cause the permanent damage.

### INPUT SPECIFICATIONS

Item	Test Conditions	Min.	Typ.	Max.	Unit
Input Surge Voltage (1sec. max.)	24VDC Input Models	-0.7	--	50	VDC
	48VDC Input Models	-0.7	--	100	
Start-up Voltage	24VDC Input Models	--	8.5	9	
	48VDC Input Models	--	17	18	
Short Circuit Input Power		--	1.5	--	W
Input Filter		π Filter			

## OUTPUT SPECIFICATIONS

Item	Test Conditions	Min.	Typ.	Max.	Unit
Output Power		0.3	--	3	W
Positive voltage accuracy	Refer to recommended circuit	--	±1	±3	%
Negative voltage accuracy		--	±3	±5	
Output Voltage Balance	Dual Output, Balanced Loads	--	±0.5	±1	
Line Regulation	Full load, Input voltage from low to high	--	±0.2	±0.5	
Load Regulation	10% to 100% load	--	±0.5	±1	
Transient Recovery Time	25%~ 50%~25% load or	--	15	25	ms
Transient Response Deviation	50%~75%~50% load step change	--	--	±5	%
Temperature Drift	100% load	--	--	±0.03	%/°C
Ripple & Noise*	20MHz Bandwidth	--	75	150	mVp-p
Short Circuit Protection		Continuous, automatic recovery			

Note: Dual output models unbalanced load: ±5%.

\*Test ripple and noise by "parallel cable" method. See detailed operation instructions at Testing of Power Converter section, application notes.

## COMMON SPECIFICATIONS

Item	Test Conditions	Min.	Typ.	Max.	Unit
Isolation Voltage	Tested for 1 minute and leakage current less than 1 mA	1500	--	--	VDC
Isolation Resistance	Test at 500VDC	1000	--	--	MΩ
Isolation Capacitance	Input/Output, 100KHz/1V	--	100	--	pF
Switching Frequency	Full load, nominal input	--	300	--	KHz
MTBF	MIL-HDBK-217F@25°C	1000	--	--	K hours
Case Material		D: Plastic (UL94-V0); MD: Steel, nickel plated			
Weight		--	15	--	g

## ENVIRONMENTAL SPECIFICATIONS

Item	Test Conditions	Min.	Typ.	Max.	Unit
Storage Humidity	Non condensing	--	--	95	%
Operating Temperature	Power derating (above 71°C)	-40	--	85	°C
Storage Temperature		-55	--	125	
Temp. rise at full load	Ta=25°C	--	15	--	
Soldering Temperature	1.5mm from case for 10 seconds	--	--	300	
Cooling		Free air convection			

## EMC SPECIFICATIONS

EMI	CE	CISPR22/EN55022 CLASS A (External Circuit Refer to Figure1-②)			
	RE	CISPR22/EN55022 CLASS A (External Circuit Refer to Figure1-②)			
EMS	ESD	IEC/EN61000-4-2 Contact ±4KV perf. Criteria B			
	EFT	IEC/EN61000-4-4 ±2KV perf. Criteria B (External Circuit Refer to Figure 1-①)			
	Surge	IEC/EN61000-4-5 ±2KV perf. Criteria B (External Circuit Refer to Figure 1-①)			

## EMC RECOMMENDED CIRCUIT

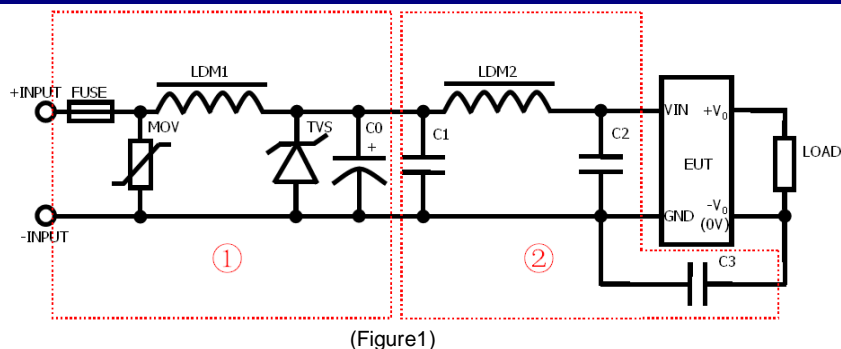

PWA\_(M)D-3W recommended external circuit parameters:

Model		PWA24_D-3W	PWA24_MD-3W	PWA48_D-3W	PWA48_MD-3W
EMS	FUSE	Choose according to load			
	MOV	10D560K		10D121K	
	LDM1	82μH		CD53	
	TVS	SMCJ48A		SMCJ100A	
	C0	120μF/50V		120μF/100V	
EMI	C1	4.7μF/50V 1210	2.2μF/50V 1210	2.2μF/100V 1210	2.2μF/100V 1210
	LDM2	3.3μH	10μH	10μH	10μH
	C2	2.2μF/50V 1210	4.7μF/50V 1210	4.7μF/100V 1210	4.7μF/100V 1210
	C3	100pF/2KV 1206	--	100pF/2KV 1206	100pF/2KV 1206

PWB\_(M)D-3W recommended external circuit parameters:

Model		PWB24_D-3W	PWB24_MD-3W	PWB48_D-3W	PWB48_MD-3W
EMS	FUSE	Choose according to load			
	MOV	10D560K	10D560K	10D121K	10D121K
	LDM1	82μH CD53	82μH CD53	82μH CD53	82μH CD53
	TVS	SMCJ48A	SMCJ48A	SMCJ100A	SMCJ100A
	C0	120μF/50V	120μF/50V	120μF/100V	120μF/100V
EMI	C1	1μF/50V 1210	4.7μF/50V 1210	2.2μF/100V 1210	4.7μF/100V 1210
	LDM2	12μH CD43	10μH CD43	10μH CD43	4.7μF/100V 1210
	C2	--	--	4.7μF/100V 1210	--
	C3	--	--	100pF/2KV 1206	--

Note: 1. In Figure 1, part ① is EMS Recommended external circuit, part ② is EMI recommended external circuit. Choose according to requirements.  
 2. If there is no recommended parameters, the model no require the external component.

### EMC RECOMMENDED CIRCUIT PCB LAYOUT

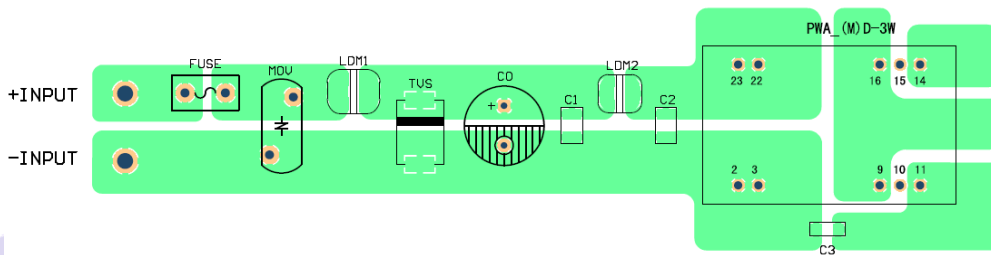

(Figure 2) PWA\_(M)D-3W series

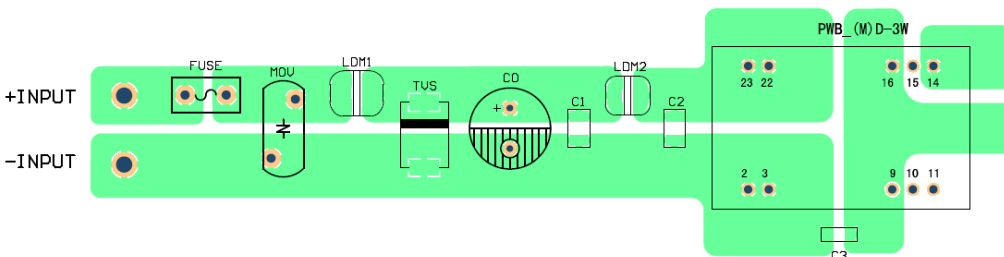

(Figure 3) PWB\_(M)D-3W series

### PRODUCT TYPICAL CURVE

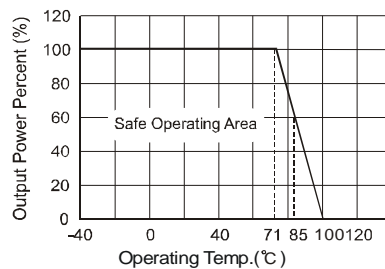

**Efficiency VS Input Voltage curve (Full Load)**

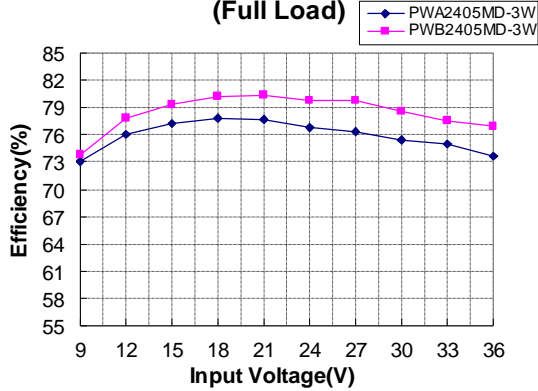

**Efficiency VS Output Load curve (Vin=Vin-nominal)**

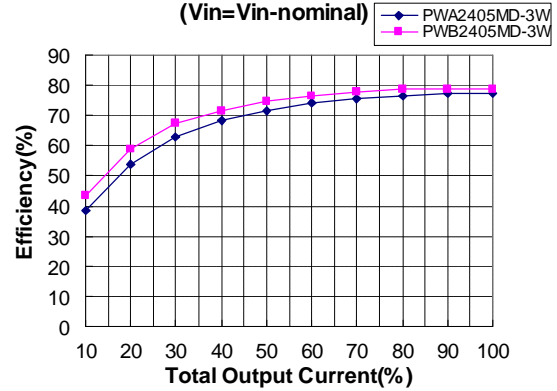

**OUTLINE DIMENSIONS, RECOMMENDED FOOTPRINT & PACKAGING**

**MECHANICAL DIMENSIONS**

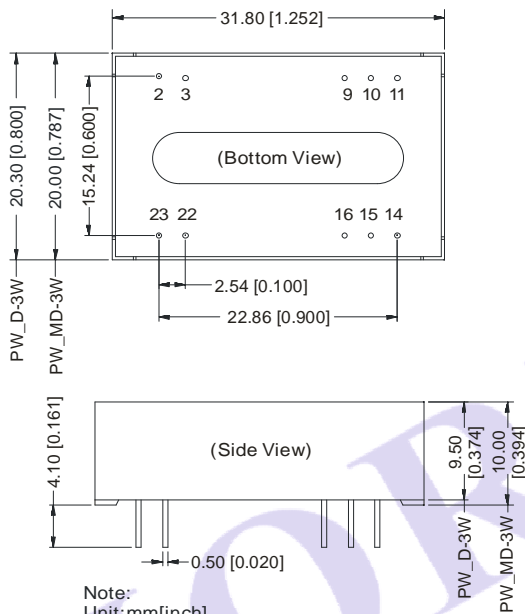

Note:  
Unit:mm[inch]  
Pin diameter tolerances:± 0.10mm[± 0.004inch]  
General tolerances:± 0.25mm[± 0.010inch]

**FOOTPRINT DETAILS**

Pin	Single	Dual
2,3	GND	GND
9	NC	0V
10,15	NC	NC
11	NC	-Vo
14	+Vo	+Vo
16	0V	0V
22,23	Vin	Vin

NC:No connection

**RECOMMENDED FOOTPRINT**

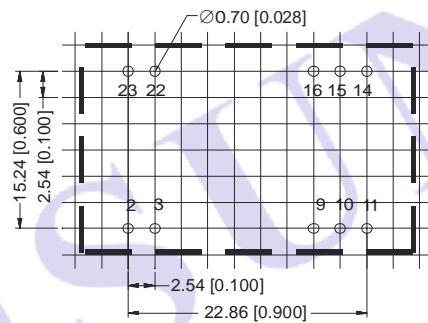

**TUBE OUTLINE DIMENSIONS**

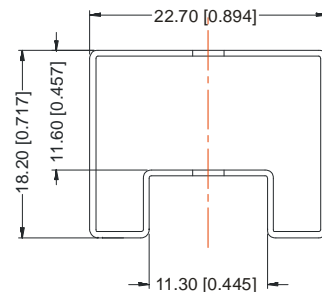

Note:  
Unit :mm[inch]  
General tolerances: ± 0.50mm[± 0.020inch]  
L=530mm[20.866inch] Tube Quantity: 15pcs  
L=220mm[8.661inch] Tube Quantity: 6pcs  
Short tube inner package dimensions: L\*W\*H= 255\*170\*80mm  
Short tube outer package dimensions: L\*W\*H= 375\*280\*270mm  
Long tube inner package dimensions: L\*W\*H= 580\*200\*100mm  
Long tube outer package dimensions(with two inner package boxes): L\*W\*H= 600\*215\*220mm  
Long tube outer package dimensions(with three inner package boxes): L\*W\*H= 600\*215\*325mm

**TEST CONFIGURATIONS**

**Input Reflected-Ripple Current Test Setup**

Input reflected-ripple current is measured with an inductor Lin and Capacitor Cin to simulate source impedance.

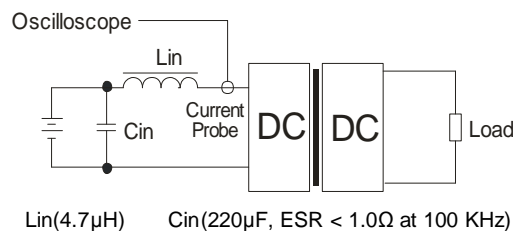

## DESIGN CONSIDERATIONS

### 1) Requirement on output load

To ensure this module can operate efficiently and reliably, During operation, the minimum output load **could not be less than 10% of the full load**. If the actual output power is very small, please connect a resistor with proper resistance at the output end in parallel to increase the load, or use our company's products with a lower rated output power.

### 2) Overload Protection

Under normal operating conditions, the output circuit of these products has no protection against overload. The simplest method is to connect a self-recovery fuse in series at the input end or add a circuit breaker to the circuit.

#### Input Fuse Selection Guide

24VDC Input Models	1000mA slow-Blow Type	48VDC Input Models	500mA slow-Blow Typ
--------------------	-----------------------	--------------------	---------------------

### 3) Recommended circuit

All the PWA\_(M)D-3W & PWB\_(M)D-3W Series have been tested according to the following recommended testing circuit before leaving factory. This series should be tested under load (see Figure 4).

If you want to further decrease the input/output ripple, you can increase a capacitance properly or choose capacitors with low ESR (see Figure 4). If the capacitance is too big, a startup problem might arise. For every channel of output, provided the safe and reliable operation is ensured, the greatest capacitance of its filter capacitor must less than the Max. Capacitive Load. If you want to use the products in high EMI, please choose our metal packaged products (PWA\_MD-3W&PWB\_MD-3W).

General: Cin: 24V&48V 10μF~47μF

Cout: 10μF/100mA

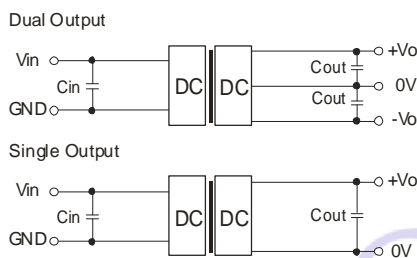

(Figure 4)

### 4) Input current

Nominal input voltage range. The input current of the power supply must be sufficient to the startup current ( $I_p$ ) of the DC/DC module (Figure 5).

General:  $I_p \leq 1.4 \cdot I_{in-max}$

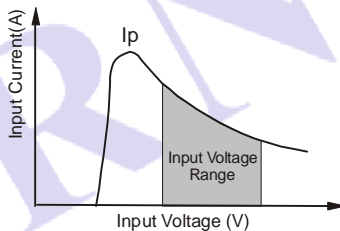

(Figure 5)

### 5) Cannot use in parallel and hot swap

Note:

1. Operation under minimum load will not damage the converter; However, they may not meet all specification listed.
2. Max. Capacitive Load tested at input voltage range and full load.
3. All specifications measured at  $T_a=25^\circ\text{C}$ , humidity<75%, nominal input voltage and rated output load unless otherwise specified.
4. In this datasheet, all the test methods of indications are based on our corporate standards.
5. All characteristics are for listed model only, non-standard models may perform differently, please contact our technical person for more detail.
6. Contact us for your specific requirement.
7. Specifications subject to change without prior notice.

#### MORNSUN Science & Technology Co.,Ltd.

Address: No. 5, Kehui St. 1, Kehui development center, Science Ave., Guangzhou Science City, Luogang district, Guangzhou, P.R.China.

Tel: 86-20-28203030

Fax: 86-20-28203068

[Http://www.mornsun-power.com](http://www.mornsun-power.com)