

F_RN-1W & F_RT-1W Series

1W, FIXED INPUT, 3000V ISOLATED & UNREGULATED SINGLE OUTPUT, DC-DC CONVERTER



RoHS

FEATURES

- Small Footprint, Ultra-thin package
- 3KVDC Isolation
- Temperature Range: -40°C ~ +85°C
- No Heatsink Required
- High Power Density
- No External Component Required
- Industry Standard Pinout
- Compatible with DCP01 Series
- Short Circuit Protection
- RoHS Compliance

PRODUCT PROGRAM

Part Number	Input		Output		Efficiency (% Typ.)	Package Style	
	Voltage (VDC)		Voltage (VDC)	Current (mA)			
	Nominal	Range		Max.			Min.
F0505RN-1W	5	4.5-5.5	5	200	20	74	
F0505RT-1W							DIP

APPLICATIONS

The F_RN-1W & F_RT-1W series are specially designed for applications where a group of polar power supplies are isolated from the input power supply in a distributed power supply system on a circuit board.

These products apply to:

- 1) Where the voltage of the input power supply is fixed (voltage variation $\leq \pm 10\%$);
- 2) Where isolation is necessary between input and output (isolation voltage $\leq 3000\text{VDC}$);
- 3) Where the regulation of the output voltage and the output ripple noise are not demanding.

Such as: purely digital circuits, ordinary low frequency analog circuits, and IGBT power device driving circuits.

COMMON SPECIFICATIONS

Item	Test Conditions	Min.	Typ.	Max.	Units
Storage humidity				95	%
Operating temperature		-40		85	°C
Storage temperature		-55		125	
Temp. rise at full load			15	25	
Lead temperature	1.5mm from case for 10 seconds			250	
Short circuit protection		Continuous, auto-recovery			
Cooling		Free air convection			
Package material		Epoxy Resin (UL94-V0)			
MTBF		3500			k hours
Weight			1.4		g

MODEL SELECTION

F0505RN-1W

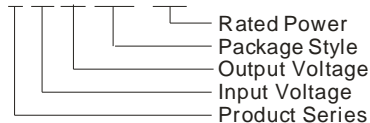

OUTPUT SPECIFICATIONS

Item	Test Conditions	Min.	Typ.	Max.	Units
Output power		0.1		1	W
Line regulation	For V_{in} change of 1%			± 1.2	%
Load regulation	10% to 100% load		12.8	15	
Output voltage accuracy		See tolerance envelope graph			
Temperature drift	Nominal input, 100% full load			± 0.03	%/°C
Ripple & Noise*	20MHz bandwidth	50% load		20	mVp-p
	Nominal input	100% load		50	
Switching frequency	Full load, nominal input		100		kHz

*Test ripple and noise by "parallel cable" method. See detailed operation instructions at Testing of Power Converter section, application notes.

MORNSUN Science & Technology Co., Ltd.

Address: 2th floor 6th building, Huangzhou Industrial District, Guangzhou, China
 Tel: 86-20-38601850
 Fax: 86-20-38601272
[Http://www.mornsun-power.com](http://www.mornsun-power.com)

ISOLATION SPECIFICATIONS

Item	Test Conditions	Min.	Typ.	Max.	Units
Isolation voltage	Tested for 1 minute and 1mA max	3000			VDC
Isolation resistance	Test at 500VDC	1000			MΩ
Isolation capacitance			15		pF

RECOMMENDED REFLOW SOLDERING PROFILE

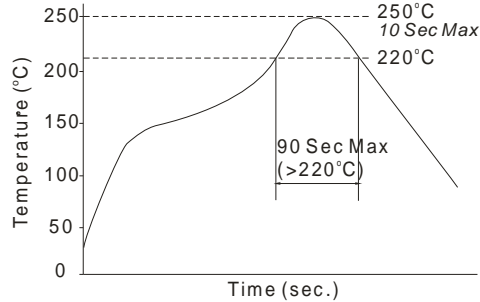

Remark: The curve applies only to the hot air reflow soldering

APPLICATION NOTE

1) Requirement on output load

To ensure this module can operate efficiently and reliably, During operation, the minimum output load **could not be less than 10% of the full load**. If the actual output power is very small, please connect a resistor with proper resistance at the output end in parallel to increase the load, or use our company's products with a lower rated output power.

2) Recommended testing circuit

If you want to further decrease the input/output ripple, an "LC" filtering network may be connected to the input and output ends of the DC/DC converter, see (Figure 1).

It should also be noted that the inductance and the frequency of the "LC" filtering network should be staggered with the DC/DC frequency to avoid mutual interference. However, the capacitance of the output filter capacitor must be proper. If the capacitance is too big, a startup problem might arise. For every channel of output, provided the safe and reliable operation is ensured, the greatest capacitance of its filter capacitor sees (Table 1).

3) Output Voltage Regulation and Over-voltage Protection Circuit

The simplest device for output voltage regulation, over-voltage and over-current protection is a linear voltage regulator with overheat protection that is connected to the input or output end in series (Figure2).

4) Overload Protection

Under normal operating conditions, the output circuit of these products has no protection against over load. The simplest method is to connect a self-recovery fuse in series at the input end or add a circuit breaker to the circuit.

4) No parallel connection or plug and play

TYPICAL CHARACTERISTICS

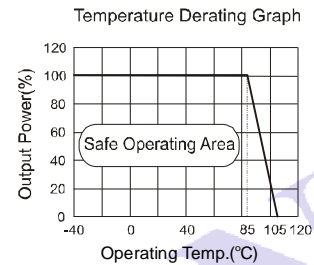
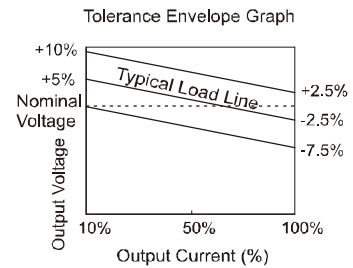

RECOMMENDED CIRCUIT

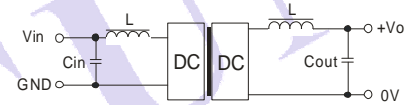

(Figure 1)

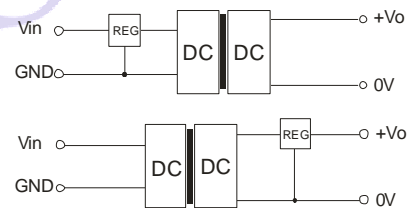

(Figure2)

EXTERNAL CAPACITOR TABLE (TABLE 1)

Vin (VDC)	Cin (μF)	Vout (VDC)	Cout (μF)
5	4.7	5	10

It's not recommended to connect any external capacitor in the application field with less than 0.5 watt output.

OUTLINE DIMENSIONS & FOOTPRINT DETAILS

MECHANICAL DIMENSIONS

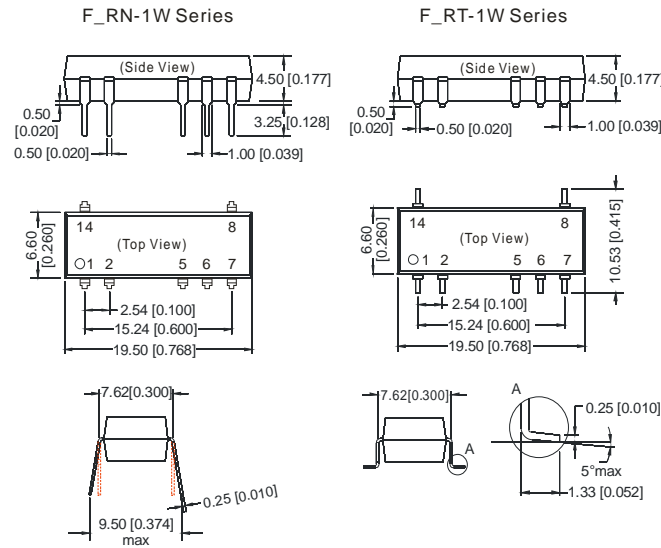

FOOTPRINT DETAILS	
Pin	Function
1	Vin
2	GND
5	0V
6	+Vo
Others	NC

NC: No connection

Note:
 Unit: mm[inch]
 Pin section tolerances: $\pm 0.10\text{mm}[\pm 0.004\text{inch}]$
 General tolerances: $\pm 0.25\text{mm}[\pm 0.010\text{inch}]$

FOOTPRINT DETAILS	
Pin	Function
1	Vin
2	GND
5	0V
6	+Vo
Others	NC

RECOMMENDED FOOTPRINT

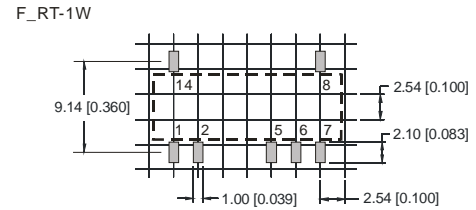
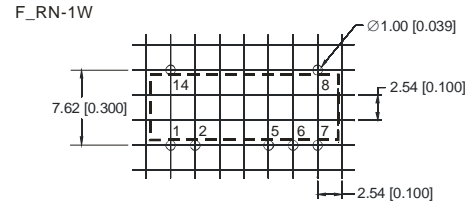

TUBE OUTLINE DIMENSIONS

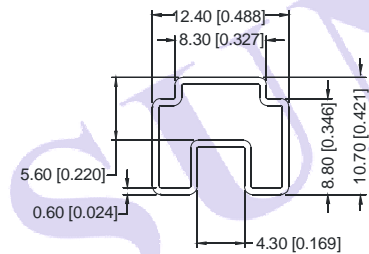

Note:
 Unit: mm[inch]
 General tolerances: $\pm 0.50\text{mm}[\pm 0.020\text{inch}]$
 L=530mm[20.866inch] Devices per tube quantity: 26pcs
 L=220mm[8.661inch] Devices per tube quantity: 10pcs

TAPING REEL DIMENSIONS

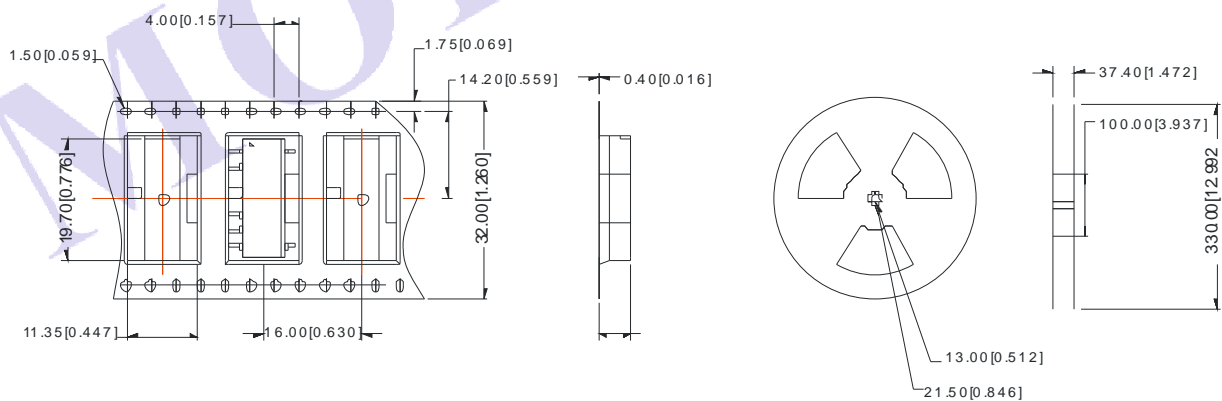

Note:
 Unit: mm[inch]
 General Tolerances: $\pm 0.5\text{mm} [\pm 0.02\text{inch}]$

Per reel of packing quantity: 500PCS

Note:

1. Operation under minimum load will not damage the converter; However, they may not meet all specification listed, and that will reduce the life of product.
2. All specifications measured at $T_a=25^\circ\text{C}$, humidity<75%, nominal input voltage and rated output load unless otherwise specified.
3. Only typical models listed, other models may be different, please contact our technical person for more details.
4. In this datasheet, all the test methods of indications are based on corporate standards.